



EZCAM<sup>®</sup>  
CAD/CAM

CNC Programming Simplified

EZ-Mill & EZ-Turn Tutorials

[www.ezcam.com](http://www.ezcam.com)

**Copyright Notice**

This manual describes software that contains published and unpublished works of authorship proprietary to EZCAM Solutions, Inc. It is made available for use and maintenance of our products. Under copyright laws, this manual, or the software it describes may not be copied in whole, or in part, without prior written consent of EZCAM Solutions, Inc., except in normal software use. The information in this document is subject to change without notice and should not be construed as a commitment by EZCAM Solutions, Inc.

All software package identifying names appearing herein prefaced with **EZ** are trademarks of **EZCAM Solutions, Inc. , All Rights Reserved.**

**EZ-CAM®** and any other references to **EZCAM** applications software are protected by

**Copyright 1999-2012 of EZCAM Solutions, Inc.  
All Rights Reserved.**

**Printed Documentation  
Copyright 1999-2012 of EZCAM Solutions, Inc.  
All Rights Reserved.**

# 1. TABLE OF CONTENTS

1.	TABLE OF CONTENTS	1
<b>CHAPTER 1.</b>	<b>INTRODUCTION AND SETUP</b>	<b>1-1</b>
	Welcome.....	1-1
	Overview .....	1-1
	EZ-CAM Installation.....	1-2
	System Requirements.....	1-3
	Installation from CD .....	1-3
	The Software Protection Key .....	1-6
	Manual Key-Driver Installation .....	1-7
	Technical Support.....	1-8
	Update Information .....	1-8
	The Application Interface.....	1-9
	The Main Window .....	1-9
	The Toolbars .....	1-10
	Selecting Elements .....	1-11
	The Value Entry Box.....	1-11
	The Selection List Box.....	1-12
	The Status Buttons .....	1-12
	The Screen Prompt.....	1-14
	The Coordinate Indicator and the Sizing Handle .....	1-14
	The Spreadsheet .....	1-15
	Screen Tool Tips .....	1-16
	Dynamic View Commands .....	1-17
	Rules for Geometrical Construction.....	1-18
	Geometry - Dynamic Preview Function.....	1-18
	Defining a Point .....	1-19
	Circle / Arc Construction .....	1-20
<b>CHAPTER 2.</b>	<b>EZ-MILL 2D TUTORIAL</b>	<b>2-1</b>
	Overview .....	2-1
	Basic Programming Steps.....	2-1
	Define Origin, Window Size and Location .....	2-4
	Setting Preferences .....	2-5
	The Part Geometry .....	2-7

Defining Circles.....	2-7
Defining Tangential Lines.....	2-9
Creating Line at Angle.....	2-11
Removing Line Segments.....	2-12
Creating Line at Angle.....	2-13
Creating a Corner Fillet.....	2-14
Defining Parallel Lines.....	2-15
Defining Circle.....	2-17
Deleting Elements.....	2-18
Defining Tangential Arc.....	2-19
Removing Line/Arc Segments.....	2-20
Defining Parallel Lines.....	2-21
Creating Corner Fillets in Pocket.....	2-22
Removing (Trim) Line Segments.....	2-23
Defining Parallel Lines.....	2-24
Creating Line at Angle.....	2-25
Creating Corner Fillets in Pocket.....	2-26
Removing (Trim) Line Segments.....	2-27
Import CAD Data (Loading DXF File).....	2-28
Moving imported Data.....	2-30
Creating the Boundary Rectangle.....	2-31
The Path Curves.....	2-33
Pocket Path Creation Rules.....	2-34
Creating the Boundary Curve.....	2-35
Creating the Contour Curve.....	2-36
Creating the Pocket1 Curve.....	2-38
Creating the Pocket2 Curve.....	2-40
Creating the 12mm Hole Curve.....	2-43
Creating the Part Program.....	2-45
Creating Work Step #1 (Roughing outside Profile).....	2-46
Creating Work Step #2 (Roughing circular Pocket).....	2-51
Creating Work Step #3 (Roughing inside Pockets).....	2-53
Creating Work Step #4 (Finishing outside Profile).....	2-56
Creating Work Step #5 (Finishing circular Pocket).....	2-59
Creating Work Step #6 (Finishing inside Pockets).....	2-64
Creating Work Step #7 (Spot-Drilling 12mm Hole).....	2-67
Creating Work Step #8 (Drilling 12mm Hole).....	2-69
Estimating Total Machining Time.....	2-72
3D Solid Preview.....	2-73
Saving the Part.....	2-75
Creating CNC Code.....	2-77



---

<b>CHAPTER 3.</b>	<b>EZ-MILL PRO / 3D TUTORIAL</b>	<b>3-1</b>
Overview .....		3-1
Cavity Machining .....		3-1
Basic Programming Steps.....		3-2
The Part .....		3-3
Setting the Preferences .....		3-4
Loading the Solid Part.....		3-6
Defining World/UCS Origin of The Part.....		3-8
Creating The Part Program .....		3-10
Creating Work Step “1_ROUGHING” .....		3-11
Creating Work Step “2_RE-ROUGHING” .....		3-15
Defining The Boundary Curves for Finishing Operation .....		3-20
Creating Work Step “3_FINISHING” .....		3-24
Creating Work Step “4_RE-FINISHING” .....		3-28
3D Solid Model Preview .....		3-31
<b>CHAPTER 4.</b>	<b>EZ-TURN TUTORIAL</b>	<b>4-1</b>
Overview .....		4-1
Basic Programming Steps.....		4-1
Defining Origin, Window Size and Location .....		4-3
Setting Preferences .....		4-4
The Part Geometry .....		4-6
Creating Fillets .....		4-8
Creating the Part Program .....		4-10
Creating Work Step #1 (Face Machining).....		4-12
Creating Tool Path for Work Step #1 .....		4-17
Creating Work Step #2 (Turning Cycle) .....		4-19
Creating Tool Path for Work Step #2 .....		4-20
Creating Work Step #3 (Profiling Cycle) .....		4-23
Creating Work Step #4 (Drilling Cycle).....		4-25
Creating Tool Path for Work Step #4 .....		4-26
Creating Work Step #5 (Boring Cycle) .....		4-28
Creating Tool Path for Work Step #5 .....		4-30
Creating Work Step #6 (Profiling Cycle) .....		4-33
Creating Work Step #7 (Grooving Cycle).....		4-36
Creating Tool Path for Work Step #7 .....		4-38
Creating Work Step #8 (Threading Cycle).....		4-41
Creating Tool Path for Work Step #8 .....		4-44
Verifying All Tool Paths .....		4-46
3D Solid Preview.....		4-47
Saving the Part.....		4-48

Creating CNC Code.....	4-50
<b>CHAPTER 5. EZ-TURN / TURNMILL TUTORIAL</b>	<b>5-1</b>
Overview .....	5-1
Basic Programming Steps.....	5-2
Defining Origin, Window Size and Location .....	5-4
Setting Preferences .....	5-5
Creating Part Geometry (Turning).....	5-7
Creating Geometry Fillets (Turning).....	5-8
Creating Path Curves (Turning) .....	5-9
Creating Part Geometry (Side-Pocket) .....	5-11
Creating Path Curves (Side Pocket) .....	5-16
Creating the Part Program .....	5-18
Creating Work Step #1 (Face Turning) .....	5-19
Creating Work Step #2 (Outside Turning) .....	5-25
Creating Work Step #3 (Pocket Milling).....	5-29
Creating Work Step #4 (Side Drilling).....	5-34
Creating Work Step #5 (Side Slotting).....	5-38
Creating Work Step #6 (Side - Pattern Drilling) .....	5-43
Creating Work Step #7 (Face - Pattern Drilling).....	5-48
Creating Work Step #8 (Face Slotting) .....	5-51
Verifying All Tool Paths .....	5-55
3D Solid Preview.....	5-56
Saving the Part.....	5-57
Creating CNC Code.....	5-59
<b>CHAPTER 6. COMMUNICATION WITH THE CONTROL</b>	<b>6-1</b>
Communication with the Control .....	6-1
Cable Diagrams .....	6-4
Cable Layout 1: XON /XOFF Software Handshake (Fanuc).....	6-4
Cable Layout 2: RTS /CTS Hardware Handshake (Heidenhain) .....	6-5
Cable Layout 3: Universal (XON/XOFF and/or RTS/CTS) .....	6-6

# CHAPTER 1.

## INTRODUCTION AND SETUP

### WELCOME

Thank you for selecting EZ-CAM as your CNC programming solution. We're confident you will enjoy many years of productive service from our products. The EZ-CAM product family has been designed to give you the best combination of simplicity and flexibility, so you can program your parts in the shortest possible time. Please use this booklet to familiarize yourself with the basic steps involved in programming a part with EZ-MILL and EZ-TURN, and the many features and capabilities available to you.



### OVERVIEW

The first chapter of this manual is intended to give you important information about hardware requirements, installation and user interface. Chapters 2 to 5 include four complete tutorials, which give you detailed step-by-step instructions describing the entire process of creating NC (Numerical Control) programs. The last chapter contains a brief overview of our EZ-DNC communications utility.

Below you will find a short description of the chapters enclosed:

- CHAPTER 1: Introduction and Setup**  
Hardware Requirements, Installation, User Interface.
  
- CHAPTER 2: EZ-MILL 2D Tutorial**  
Advanced 2D Part to explain general Handling, Geometry Creation and 2D Machining.
  
- CHAPTER 3: EZ-MILL Pro / 3D Cavity Machining Tutorial**  
Advanced 3D Part to explain Data Import and 3D Surface Machining.
  
- CHAPTER 4: EZ-TURN Tutorial**  
Standard 2D Turning.

**CHAPTER 5: EZ-TURN & MILLING Tutorial**  
Turning & Live-Tool Machining.**CHAPTER 6: EZ-DNC (Communication)**  
Communication with the Machine (via RS232).

Throughout the manual you will find important notes , tips  or references to the online help where additional information on the commands and functions is provided.

**EZ-CAM INSTALLATION**

View the subsequent paragraphs for more information about system requirements, installation instructions and the software protection key.



Before adding new modules or installing any software updates, it is strongly recommended to backup all EZCAM related INI files that are located in the operating systems main directory (normally “C:\WINDOWS”). Although existing INI files are not overwritten during the setup process, newly installed EZCAM applications may modify the files so they cannot be used with previous versions in case the system needs to be restored.

EZCAM.INI	All EZCAM Applications (Default Settings, last used Files/Folders)
EZ-CAM19.INI	EZ-Mill & EZ-Turn (Screen & Toolbar Layout)
EZ-CAMX19.INI	EZ-Mill & EZ-Turn Express (Screen & Toolbar Layout)
EDM19.INI	EZ-EDM (Screen & Toolbar Layout)

## SYSTEM REQUIREMENTS

Before you begin the setup process, please confirm that your system meets the following minimum requirements:

Component	Minimum Requirements
Operating System *	Microsoft ® Windows XP Home/Professional Microsoft ® Windows Vista Home/Professional Microsoft ® Windows 7 Home/Professional
Processor	2.8GHz Pentium 4 / 2.0GHz Core 2 / AMD 2400+ or faster
Memory	2 GB recommended **
Hard Disk Space	420 MB, depending on type of installation
Display	256-color Graphic Adapter, Open-GL support Color Monitor capable of 1024x768 pixel resolution (1280x1024 recommended)  For 3D solid simulation & surface shading: True Color, 1 GB RAM, Open-GL support

\* Both 32 and 64 bit systems are supported

\*\* Check operating system requirements

## INSTALLATION FROM CD



Remove the USB software protection key from the computer before starting the setup

1. Close all applications and insert the EZCAM setup CD.

If “Autorun” is enabled on your system, the installation starts automatically and brings you to the “Welcome” dialog. Select the “Install EZCAM” option and continue with Step 4 below.

2. Select the “Run” command from the “Start” menu.

3. Type “D:\setup” (substitute the appropriate letter of your CD-ROM drive for D) and select “OK” to start the installation routine.
4. Once you agreed to the “License Agreement” you’ll come to the dialog that defines the destination folder (default “EZCAMW”). Continue pressing “Next”.
5. The next dialog gives the choice of “Typical” or “Custom” setup type. Choose “Typical” for complete installation or “Custom” if you would like to customize the selection of EZCAM modules that are installed. Continue pressing “Next”.

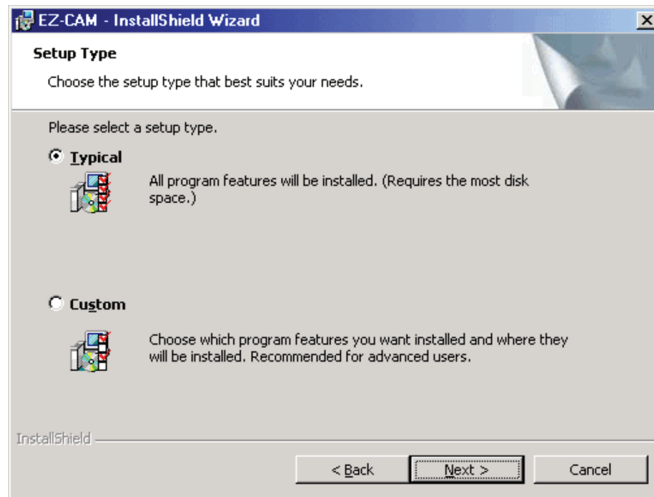

- If “Custom” was selected, the dialog shown below is used to select the desired modules. Continue with pressing “Next”.

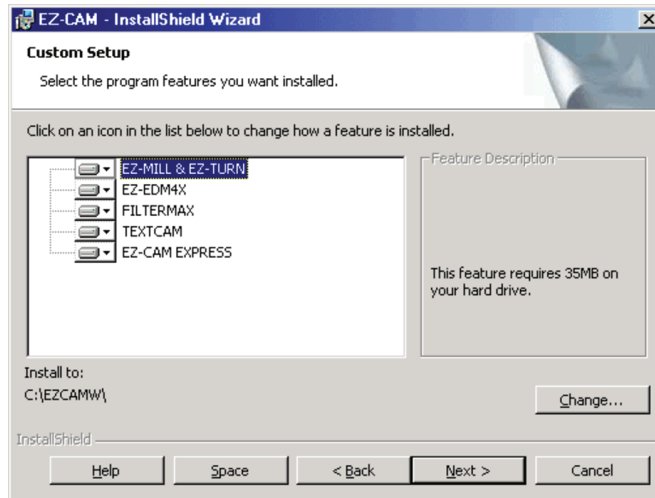

EZ-Mill / Mill Pro and EZ-Turn users are also licensed to install and use the Express versions of their products (Mill/Mill Pro ⇒ Mill-Express, Turn ⇒ Turn-Express).

- Follow the instructions on the screen to complete the installation. Setup then installs all necessary files onto your hard disk and creates the EZCAM program group. In addition an icon for every installed module is created on the desktop.

## THE SOFTWARE PROTECTION KEY

Every EZCAM package is shipped with a software protection device from SafeNet (also referred to as Dongle) which can be plugged to any of the USB ports. The SafeNet system driver is automatically installed by the EZCAM setup so that all applications correctly detect this key. If the dongle is not detected all saving/posting options are disabled.



USB Type Dongle



- The SafeNet system driver is automatically installed by the EZCAM setup. Manual driver installation is only necessary in case the automatic driver installation during the EZCAM setup fails !



## MANUAL KEY-DRIVER INSTALLATION

As mentioned previously, manual driver installation is only necessary in case the automatic installation fails or a driver update is required.



- You must login using an account with administrator privileges to install software drivers under Windows XP / Vista / 7.
- Remove the USB key from the computer before starting the driver setup.

### **Procedure:**

1. Start Windows Explorer.
2. Navigate to the 'Rainbow' folder located in the EZCAM installation directory.
3. Double-click 'Setup.exe' to start the Rainbow Technologies Setup.
4. Select the 'Complete' installation and click "Next" to continue.
5. Finally select the 'Finish' button to exit Setup.

## TECHNICAL SUPPORT

Software purchased directly from EZCAM Solutions Inc. includes 1 year of technical support and maintenance.



As our technical staff uses current versions of the product it is highly recommended that you upgrade when new major releases, fixes or incremental patch updates become available. Only then, we can guarantee that our application expertise in the form of example files, posts, etc. can be applied without any incompatibilities.

## UPDATE INFORMATION

As with any software purchase, to get the most out of your investment and to ensure the years of trouble free service and support, it is highly recommended that you upgrade when new major releases become available. As EZCAM enhances the software, all registered users will be notified by mail of software updates. Updated software will be available to registered users at special low prices. You can visit EZ-CAM's web site at [www.ezcam.com](http://www.ezcam.com) for latest information.

## THE APPLICATION INTERFACE

The following paragraphs are intended to give an overview of the application interface with all its toolbars, list boxes, and command buttons together with some general rules for geometry construction.

## THE MAIN WINDOW

The graphic below represents the general screen layout for the EZ-CAM applications with standard toolbar layout. The purpose of this figure is to show you the locations of the most important screen elements that are described on the following pages. In addition to that you will learn about toolbars, how and where to input numeric values and much more. All this information is very helpful when you later step through the tutorials. The EZ-EDM and EZ-TURN screen differs only slightly.

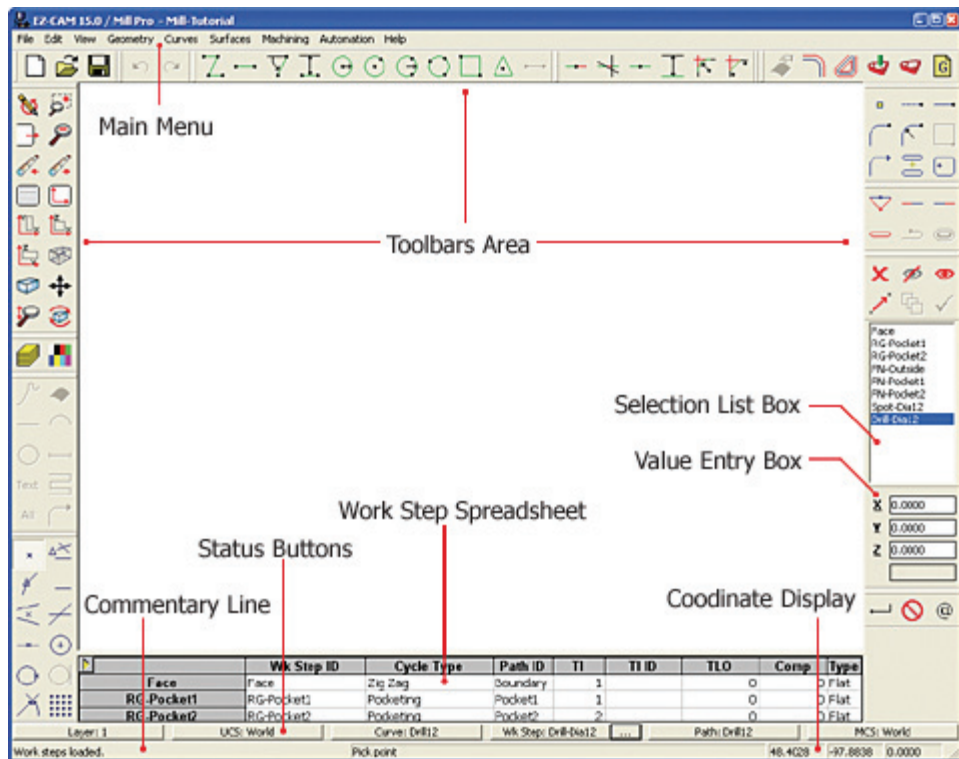

EZ-CAM Main Window (EZ-MILL Pro)

## THE TOOLBARS

The first order of business is to acquaint you with the major features of the EZ-CAM screen. Let's start with the toolbars. In the basic layout, you will find several icons (command buttons) grouped together in so called "toolbars" surrounding the drawing space. Each button functions as a shortcut to an actual menu command. Buttons save you time because they eliminate the necessity of searching through menus and submenus. The toolbars can be positioned anywhere (floating) within the EZ-CAM screen. This positioning is known as "docking". Left, right, up or down, whatever you choose.

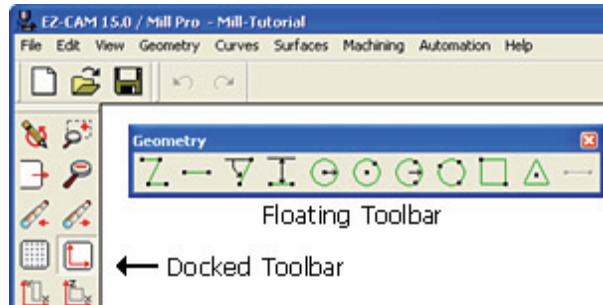

The buttons have been meticulously designed for ease of recognition. For example, you'll notice the geometry buttons all have the same color scheme. This light green color is used for all geometrical elements created in EZ-CAM. After a short period of time you'll have these button images memorized. In the meantime, you'll need to take advantage of a feature called a tool tip. When you position the cursor over the button and hold it there it momentarily, the name of the button command will be displayed.

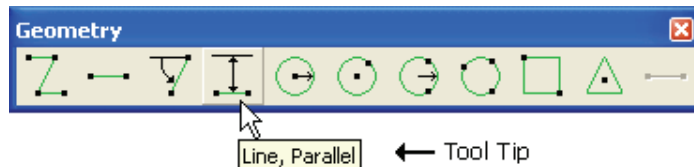

A toolbar can accommodate as many buttons as you wish. It will automatically stretch to fit the number of rows or columns that you designate. When creating toolbars, you have control over what goes in them and how they should be named



See "Toolbar" section in the "Screen Layout" book of the online help for more information about customizing, moving or docking of toolbars.

## SELECTING ELEMENTS

Whenever you want to perform an action on one or more elements (geometry, path, etc.), you have to select them prior to execution of the function. For example, if you want to delete an entity from the view port, you must first click the Delete button and then select the desired entity. This can be done by selecting (click) each single element using the cursor or by placing a selection box (rectangle) around all the desired elements. Only the ones that are entirely enclosed in this box are selected and displayed in a dotted style. If you select the wrong one just click on this element again and it's deselected.

## THE VALUE ENTRY BOX

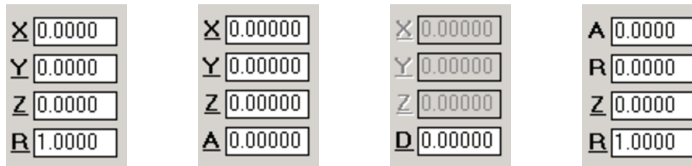

Having a look on the pictures above, you'll notice that the caption of the input fields in the "Value Entry Box" are changing according to the current input mode and selected command. The first three fields are directly related to the selected "point picking" mode and normally used for entering X, Y, and Z coordinate values. The only exception is shown on the rightmost graphic, where the "Polar Mode" is activated requiring angular and radius inputs. The lowest field is depending on the selected geometry command. If you were creating a circle, the Value Entry Box would appear as it does in the first example. The letter "R" stands for Radius. If you were creating a line at an angle to an existing line, the "Value Entry Box" would appear as it does in the second example showing "A". The letter "D" stands for distance and is visible when using the "Lines, parallel" or "Offset" command. The Value Entry Box takes its cue from you. It will change instantly to conform to your actions.

There are two ways to input X, Y, Z coordinate information. You can manually type the coordinate for each field or you can right-click the mouse to copy the cursor's current position in the viewport into each respective coordinate field. When all of the fields in the Value Entry Box contain a value, you can either press the Enter key on your keyboard or click the Enter button located below the "Value Entry Box". The best way to go from field to field within the "Value Entry Box" is to apply the Windows navigation standard: TAB = forward, SHIFT/TAB = backward; or UP ↑ and DOWN ↓ buttons.

## THE SELECTION LIST BOX

The Selection List Box generally changes its content according to the selected command and operation (Delete, Blank, etc.). Each time you start an operation where elements or entities have to be selected, the selection list box is automatically filled with the appropriate items. The list box content can be controlled even further by the use of the discrimination options. By doing this it is for example possible to display only curves or arcs.

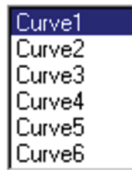

Curves

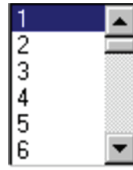

Layers



Colors

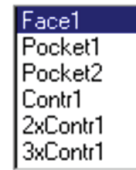

Work Step's

When more than 12 items are present in the Selection List Box, a scroll bar is automatically activated. To select an item, just click once on the item you want. When you are prompted to select an entity, a list of selectable ID names will appear in the Selection List Box. In most cases, you may either select the item directly from the view port or click on its ID name in the List Box. For instance, if you wanted to delete a curve, you would first click on the Delete button and then either click on the curve in the view port or select its Curve ID from the List Box. To edit a specific Work Step simply double-click on the corresponding entry in the list and make your changes in the Machining dialogs (for further information about Work Step reordering using the List Box, please see “The Spreadsheet” section).

## THE STATUS BUTTONS

The Status buttons are located at the bottom of the screen. They are used to display and change current status information. For example you may want to change the curve that is assigned to the current Work Step displayed on the “Wk Step” button. In this case select the “Path” status button and select one of the available curves in the view port or from the selection list box. The ID of the newly selected curve will now be displayed on the “Path” button.



This button displays the currently active layer and is also used to switch layers when pressed. The available layers are then displayed in the Selection List Box for being selected with the cursor.



This button displays the currently active User Coordinate System and is used to switch between available UCS systems. When selected, all available UCS systems will be displayed on the screen and in the Selection List Box. Use the cursor to select the desired UCS system in the view port or from the list box.



### Important !

XYZ coordinate input is directly related to the coordinate system that is displayed on the “UCS” status bar. If no user defined UCS is available the “World” system will be displayed by default.



This button displays the currently active Curve ID. To change the currently active curve, simply click on the “Curve” status button and select one of the available curves in the view port or from the selection list box.



Curve creation and editing commands are only applied to the curve displayed on the curve status button. Therefore it is very important to select the correct curve before executing any curve editing or creation commands.



Now here's an interesting button. Actually, it's two buttons in one. The button on the left is used to display or change the current Work Step. The other button opens the “Work Step Data” dialog with the currently active Work Step for editing purposes.



The current display of the “Path” (machined curve) and “MCS” (Machine Coordinate System) status buttons directly refer to the Work Step ID displayed on this status button. Before applying any changes make sure that the appropriate Work Step is selected.

A rectangular button with a light gray background and a dark border. The text "Path: Curve1" is centered in a black sans-serif font.

This button is used to display and change the curve (path) that is assigned to the currently active Work Step that is shown on the “Wk Step” button.

A rectangular button with a light gray background and a dark border. The text "MCS: World" is centered in a black sans-serif font.

This button is used to display and change the **Machine Coordinate System** that is assigned to the currently active Work Step that is shown on the “Wk Step” button.

## THE SCREEN PROMPT

The screen prompt is located at the very bottom of the screen. You'll find it necessary to refer to the prompt when working.

A horizontal screen prompt bar with a light gray background and a dark border. It is divided into two sections by a vertical line. The left section contains the text "Create line by two points" and the right section contains "Pick first point".

Here's a condensed version of the screen prompt. In this example, a line using the “Line, two Points” command is being created. The left-hand portion of the screen prompt tells you the purpose of the button or menu command. The right-hand portion of the prompt tells you what to do. In this example, once the first point has been picked or entered, the prompt will give more instructions for the second point.

## THE COORDINATE INDICATOR AND THE SIZING HANDLE

At the bottom right-hand corner of the screen (adjacent to the screen prompt) is the coordinate indicator. It gives you the exact X, Y, and Z coordinates of your cursor position. The coordinate indicator changes constantly as you move your cursor around the view port.

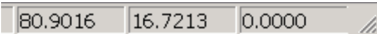
A horizontal coordinate indicator bar with a light gray background and a dark border. It contains three rectangular boxes with rounded corners. The first box contains the number "80.9016", the second contains "16.7213", and the third contains "0.0000". To the right of the third box is a small, dark, right-pointing triangle (the sizing handle).

To the right of the coordinate indicator is a little triangle. This little triangle is known as the sizing handle. If you want to resize the EZ-CAM main window, first position your cursor on the sizing handle. Then hold the mouse button down and drag the window until it is the size you want.



## THE SPREADSHEET

Located on the lower portion of the main window is the spreadsheet. Each spreadsheet column contains valuable machining data that you can edit locally or globally. In the spreadsheet you can activate/deactivate/reorder or delete previously defined Work Steps. Reordering can be accomplished by using UP ↑ and DOWN ↓ keys after selecting the entire row of the Work Step by clicking in its leftmost ID column.



Alternatively, Work Step activate/deactivate/reorder operations can be handled using the Work Step Selection List Box in the toolbar. You can activate/deactivate a Work Step by clicking on it with the right mouse button. In order to move a Work Step up or down, first select it with left click and then use LEFT ← or RIGHT → keys on the keyboard.

One way of making the spreadsheet visible is to select the Show Spreadsheet command from the “Work Step” menu which automatically sets its size according to the number of work steps. Now we will show you another way to make the spreadsheet visible:

Place your cursor just above any of the buttons at the bottom of the screen.

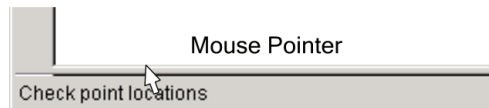

When the mouse pointer changes to  , drag it up to the position you want.

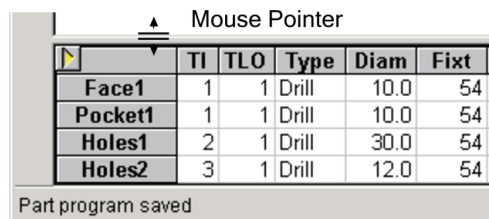

## SCREEN TOOL TIPS

As we previously mentioned, every button has a tool tip. When you position the cursor over a button momentarily, the tool tip is activated and the name of the button is displayed. Tool tips come in very handy when you are getting accustomed to a new software package. We've taken the concept of tool tips and applied them to Surfaces, Curves, and User Coordinate Systems. How does this benefit you? We'll explain.

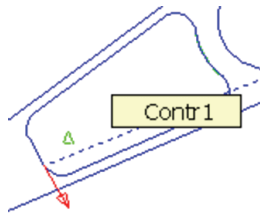

Curve ID

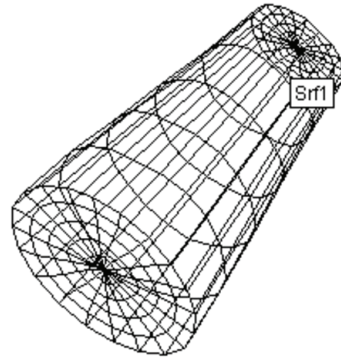

Surface ID

In EZ-CAM, by default blue lines represent curves. In a complex part, with let's say 30 curves, a real problem arises. One blue line looks exactly like another. The screen tool tip becomes extremely useful to you when you need to differentiate one entity from another.

## DYNAMIC VIEW COMMANDS

The standard views that are available via the “View” menu or the corresponding Icons in the “View” toolbar are sufficient for most cases. Sometimes however, it is desirable to set the view direction to a freely chosen angle. This option is available in EZ-CAM through dynamic viewing commands. The current view can be changed by using any of the dynamic “Rotate”, “Zoom” or “Pan” functions.

When selecting dynamic viewing commands one of the following cursors will be displayed.

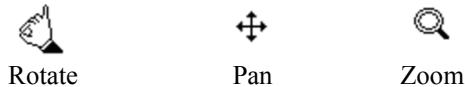

Hold the left mouse button down then drag the mouse across the screen. The part will directly follow the cursor movements according to the command selected. When you release the mouse button the screen will be re-drawn in the new Orientation. In idle mode when no EZ-CAM command is active (pressing ESC key aborts the current command) holding right mouse button down and dragging applies dynamic rotation; holding middle button down and dragging applies panning; rotating mouse wheel forward / backward zooms in and out.

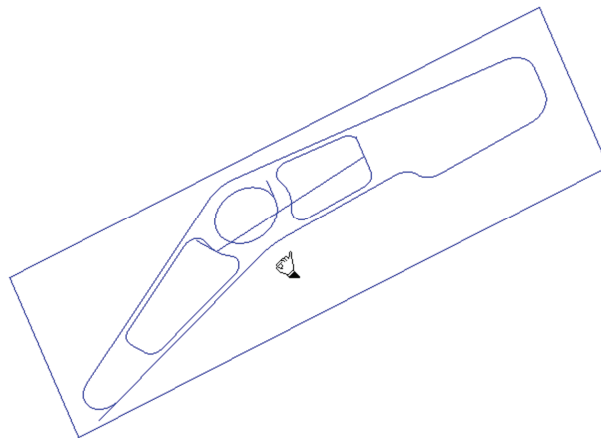

**Dynamic Rotate**

## RULES FOR GEOMETRICAL CONSTRUCTION

Geometry is always based on the currently active coordinate system (World or User defined coordinate system, also referred to as UCS). When several alternative solutions to a construction exist, moving the screen cursor will show the alternative that lies closest to the cursor position in white. When the correct solution is shown, a click with the left-hand mouse button will carry out the construction (this function is called dynamic preview).

### GEOMETRY - DYNAMIC PREVIEW FUNCTION

The geometry construction has been provided with a Dynamic Preview Function. This function provides a visual check on the construction before it is actually performed. If there are several solutions to a construction (which is often the case) moving cursor on the screen will select the nearest solution and the new element will be shown highlighted. When the correct solution is shown, a click with the left-hand mouse button will carry out the construction and the new element will be drawn.

In the following example we will look at the construction of a circle that must lie tangential to three existing circles. If you look at the graphic below you can see that two tangent points on circles A and B have already been chosen. The final construction has two possible solutions, depending upon which side of the third circle is picked. As the screen cursor is moved nearest to one side or the other, the possible new circle will be highlighted. A click with the left-hand mouse button will confirm the selection and the circle will be drawn on the screen.

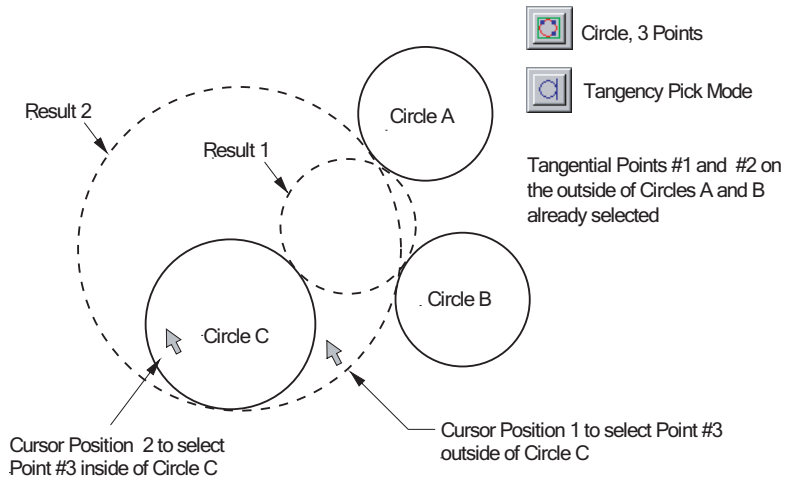

## DEFINING A POINT

Whenever you have to define a point, no matter if it's an endpoint of a line or the center of a circle, you have two choices. You can use one of the **SNAP Modes** by selecting the corresponding icon on the toolbar or input the values directly in the fields of the "Value Entry Box".

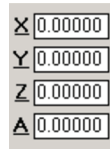

Value Entry Box

When you want to use coordinate input, just click in one of the input fields (X, Y, Z). You can move between these fields by using the TAB or UP ↑ / DOWN ↓ keys and input the desired values. After all values are input press ENTER. The point will be accepted and displayed by the system.

You may be wondering what SNAP modes are. Here is a picture of the standard SNAP Mode toolbar with the modes named.

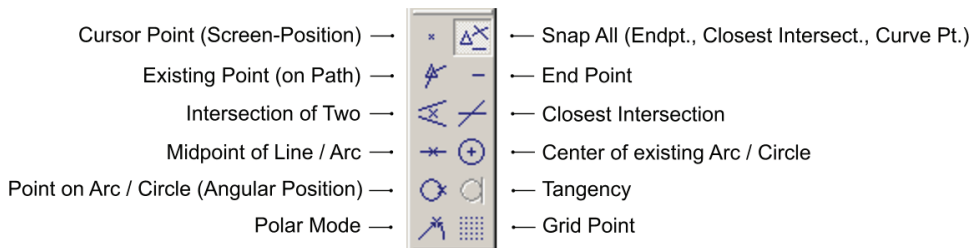

These are the most commonly used snap modes to pick an existing point on the screen, for example the endpoint of a line, a tangential point or the intersection between two geometry elements.

Here is how it works: first choose the type of element you want to create. Then select the appropriate snap mode icon in the toolbar and move the cursor to the desired point on the screen. The software will automatically snap to the closest point and the dynamic preview will display the result on the screen. If this is the point you want to select, just click the left mouse button and the point will be yours.

## CIRCLE / ARC CONSTRUCTION

The graphical user interface is streamlined by combining circle and arc construction into the same button command. The buttons shown below are used for creating circles and arcs.



Circle/Arc, Center, Radius



Circle/Arc, Center Edge



Circle/Arc, Two Points, Radius



Circle/Arc, Three Points

The most common of them are available on the standard button layout while the others are accessible through the “Geometry” menu. By default, clicking any of these buttons will result in a circle. To create an arc, you’ll need to click the “Finite” Mode button shown below or the corresponding command in the “Geometry” menu. This command functions as a toggle between infinite and finite geometry construction.



Finite Mode

Remember, if you don't want to go around in circles, click the “Finite” Mode button.



The “Finite Mode” also applies to the “Line, parallel” and “Line at Angle” line creation commands.



Line, parallel



Line at Angle

# CHAPTER 2.

## EZ-MILL 2D TUTORIAL

### OVERVIEW

This tutorial is intended for users with little, or no experience in EZ-Mill operations. The step-by-step instructions describe the complete process of creating the NC program for the 2D part shown in **Picture 2-1**, focusing on the machining process and also describing more advanced techniques used for roughing, finishing and Work Step handling using the integrated spreadsheet. In addition we show you how to import CAD data by loading and arranging a DXF file.

### BASIC PROGRAMMING STEPS

Before we continue with the tutorial let us explain the basic steps needed to create a part program with EZ-Mill.

- STEP 1.            Create Geometry**  
Start by creating part geometry via commands under the Geometry Menu, or alternatively, use “File/Open” command to import geometry data from CAD sources (IGES, DXF, DWG, etc.)
- STEP 2.            Define Path Curves**  
Use the “Curves” menu commands like CHAIN, ARC, LINEAR, etc. to define curves by tracing or chaining existing geometry.
- STEP 3.            Create Work Steps and set Machining Parameters**  
Define Work Steps for each machining operation and apply the parameters as required by type of operation and tool that is used. Assign the desired path curve to each Work Step. Visualize the computed tool path to assure correct tool operation and proper setting of machining parameters.

**STEP 4.**

**Post G-Code**

Select the “Postprocessor” related to the type of control and let the software create the G-Code file.



The EZ-Mill 2D Tutorial is set up in Metric with all Inputs and Dimensions in Millimeters !

Users who want to skip the geometry creation may start with the “Import CAD Data” topic at the end of the geometry section.



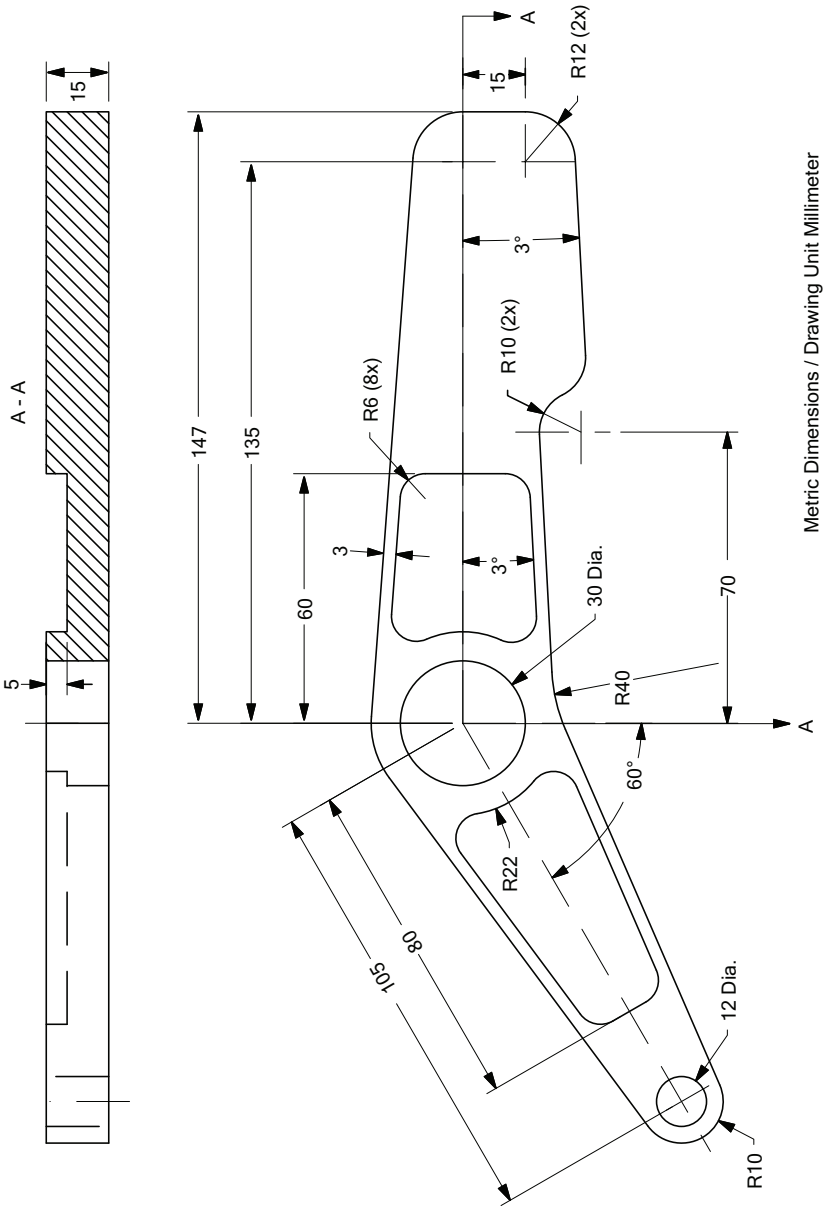

Metric Dimensions / Drawing Unit Millimeter

Blueprint of EZ-Mill 2D Tutorial

Picture 2-1

## DEFINE ORIGIN, WINDOW SIZE AND LOCATION

The window size is the distance from the edge of the window to the center of the window. The window location is the signed, absolute position of the window center from the part's origin. The viewing parameters that are found in the Setup dialog box specify the size and location of the window. Note that you would not normally perform this step in programming a part, but it is necessary here to insure clarity in following the tutorial. Normally, you would just use the *Zoom/Fade* commands to set the window size as needed.

When selecting the origin for the part, choose a location that is referenced by the part's dimensions. The origin should be selected before defining the window location (see next topic for setting up the workspace), because the window center is referenced from the part's origin. The graphic in **Picture 2-2** below shows the location of the part origin for this exercise ( $X = 0, Y = 0$ ).

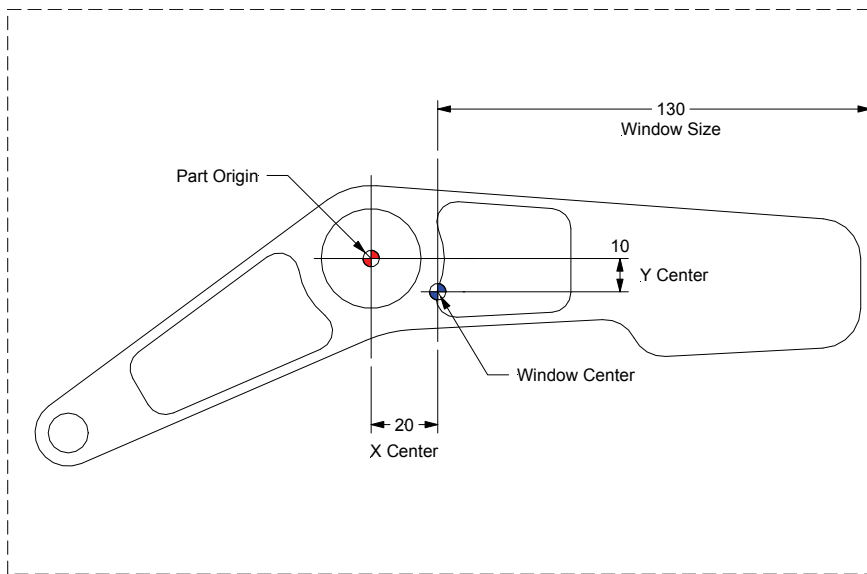

**Picture 2-2**

## SETTING PREFERENCES

Before continuing with the construction of the sample part, several parameters should be set so that the system is compatible with the instructions in this tutorial. Also the size of the workspace should be set. The sample part is about 250mm in the X-axis and 85mm in the Y-axis. Because of the size of the part, it is not convenient to work in the default window; therefore the window and some default settings have to be changed.

1. Select "New" command from the "File" menu to restart EZ-Mill and to clear the memory before continuing with the tutorial. Make sure that one of the EZ-Mill levels is active and press OK to start over.

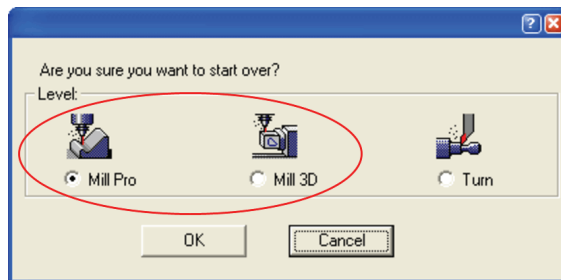

The "New" dialog is also used to switch between the EZ-Mill and EZ-Turn module. Before the dialog opens, the system checks the software protection key for activated modules. Modules or levels that are not activated will be marked by appended "DEMO" text. When working in "Demo" (evaluation) mode, it is not possible to print or save data. The corresponding "Save", "Save as" and "Print" commands are disabled.

When closing the EZCAM application, the system automatically stores the last used level as default for the next session.

2. Select "Setup" command from the "View" menu
3. Type "20" for "X Center", "-10" for "Y Center" and "130" for "Size". This sets the window size from the edge of the window to the center of the window, allowing enough room to see all of the part as it is created. See **Picture 2-2**.

4. Select “Metric” option button as the parts input dimension system.
5. Click the “Background” list box and select “Black”.
6. Check the box "Blank Verify" on the right. This will cause verified tool paths to be blanked every time the view is changing or the screen is redrawn.
7. Check the box "Save as Default". The system will store all dialog settings as defaults for future sessions.
8. After the preferences have been correctly set, click OK.

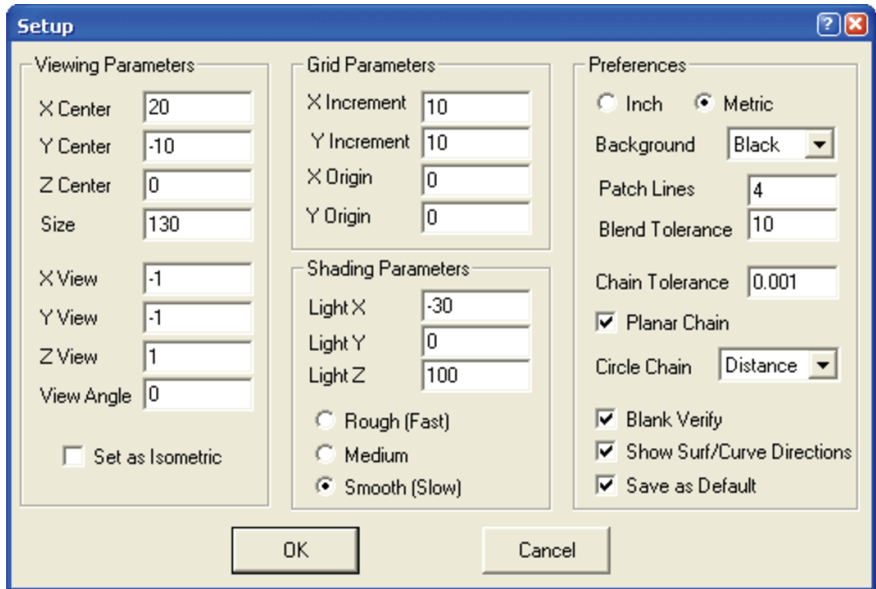

The initial setup for the EZ-MILL 2D tutorial is now complete. Continue with the next section to create the geometry necessary for this part.

## THE PART GEOMETRY

Now that the workspace has been adjusted to accommodate the part, the creation of the part can begin. This involves creating geometry that is used to define the tool paths. Before you begin check that the current view is set to X-Y.

To change system view to X-Y, click the X-Y view  button.

First, we will create the geometry that defines the outside contour of the sample part. Then we continue with creating the pockets. At any time you may use the Undo/Redo buttons in the upper left corner to correct any mistakes you make.

## DEFINING CIRCLES

Follow these steps to create the first circles that define the basic geometry of the sample part.

1. Select the “Circle/Arc, Center, Radius” button.



Circle/Arc, Center, Radius

2. For the Radius of circle #1, type “15” in the “R” field of the Value Entry Box on the lower right side of the EZ-Mill screen. Make sure the X, Y, Z coordinate values are set to “0” (default value).

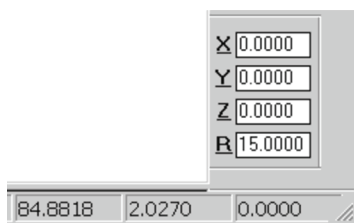

3. Press the ENTER button (The first circle should be displayed at the part origin).

4. For the Radius of circle #2, type “22” in the “R” field of the Value Entry Box. As the center coordinates of the second circle are same (X0/Y0), simply press the ENTER button to create the second circle.
5. For the Radius of circle #3, type “12” in the “R” field of the Value Entry Box, then press Tab to move the focus to the “X” input field. Type “135” for the Center X location. Y position should already be set to “0”. Press the ENTER button to create third circle.
6. To create circle #4, press Tab until focus is set to the “Y” input field. Type “-15” for the Center Y location and press the ENTER button.
7. To create circles #5 and #6 we use the “polar coordinate” input mode. Select the “Polar Mode” option located in “Edit / Point Picking” menu. When selected you will see a small checkmark in the menu indicating the option is activated. Every selection of this menu entry toggles the polar mode “On” or “Off”.



Polar Mode

8. The content of the Value Entry Box will change as shown below. Input “210” in the “A” field as the polar angle and “105” in the first “R” field as the polar radius to specify the center of the circle #5 by using polar coordinates. In the second “R” field input “10” for the radius of the new circle itself and press ENTER button. The polar origin is always located at the origin of the current coordinate system.

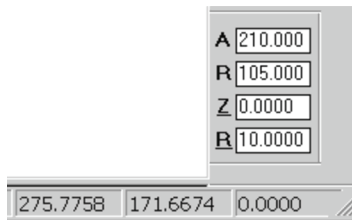

9. To create circle #6, change the radius value to “6” and press ENTER. Now your part geometry should appear as in **Picture 2-3**. Do not forget to toggle the “Polar Mode” to “OFF” condition when finished.

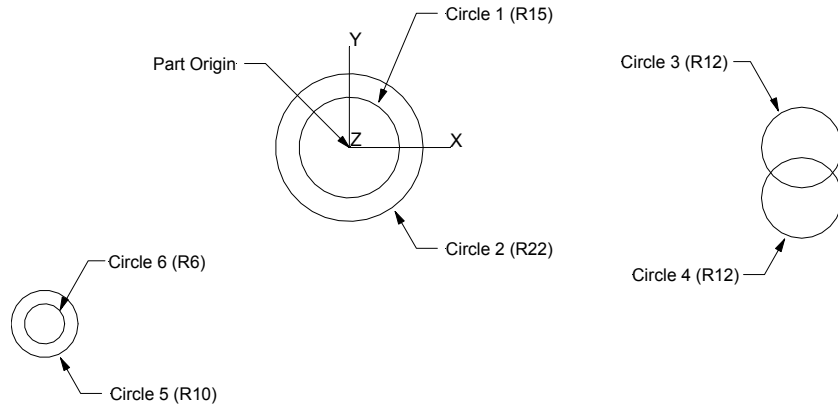

**Picture 2-3**

## DEFINING TANGENTIAL LINES

The next step is to define tangential lines to connect the R10, R22 and R12 circles.

1. First select the “Line , Two Points” ,then the “Tangency” button.



Line, Two Points



Tangency

2. When the "Pick First Point" prompt displays in the message area, click slightly above the R10 circle #6 (see POS #1 in **Picture 2-4**).
3. Then the "Pick Second Point" prompt displays. Now move the cursor to the right, slightly above the R22 circle (see POS #2 in **Picture 2-4**). The geometry preview will show the next possible line. If it is OK confirm the action with a mouse- click. The new line is drawn tangent between the R10 and R22 radius circles.

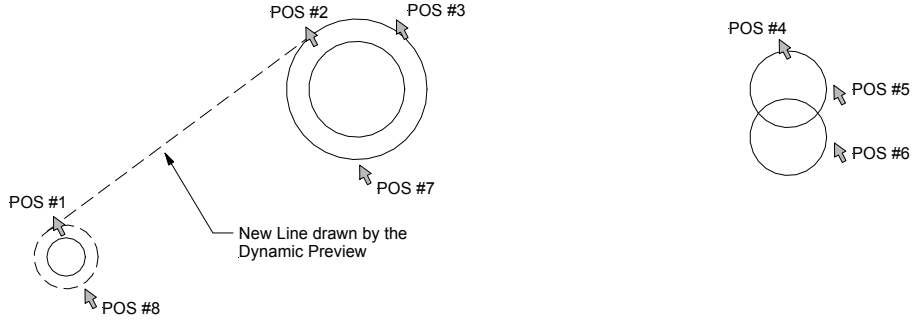

**Picture 2-4**

4. Continue with creating lines by selecting POS #3 and POS #4 to connect the R22 and R12 circle, POS #5 and POS #6 to connect both R12 circles, POS #7 and POS #8 to connect the R22 with the R10 circle again. See **Picture 2-5** for the resulting geometry.

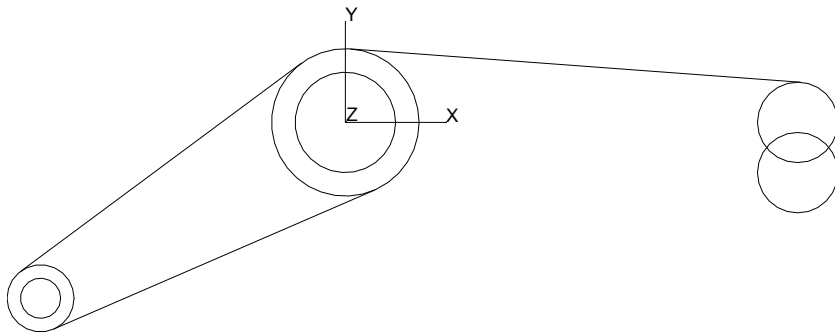

**Picture 2-5**



## CREATING LINE AT ANGLE

The next step is to define a line that lies tangential to the R12 circle at an angle of 3 degrees to the X-axis.

1. Select the “Line at Angle” button.



Line at Angle

2. Click the X-axis coordinate system handle with the mouse to define the reference axis for the angle.

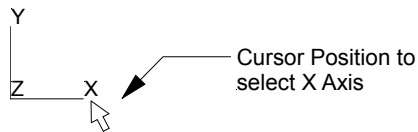

3. Type “3” in the “A” field of the Value Entry Box (Do not press ENTER).
4. Select the “Tangency” button.



Tangency

5. Move the cursor to a position slightly below the R12 circle as shown in **Picture 2-6**. The geometry preview will show the new line. If it is OK confirm the action with a mouse click.

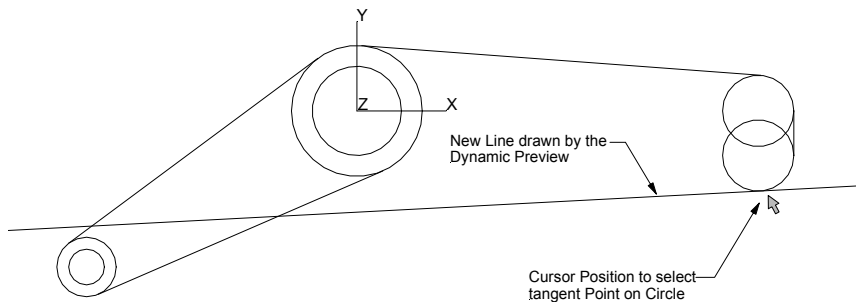

**Picture 2-6**

## REMOVING LINE SEGMENTS

Follow the instructions below to remove some of the line segments.

1. Click the “Remove to Closest” button. This command will allow you to remove a segment of a line, arc, or circle between the closest boundaries.



Remove to Closest

2. At the "Pick Line, Arc or Circle" prompt, select the line segments to be removed as shown in **Picture 2-7**. The result should appear as in **Picture 2-8**.

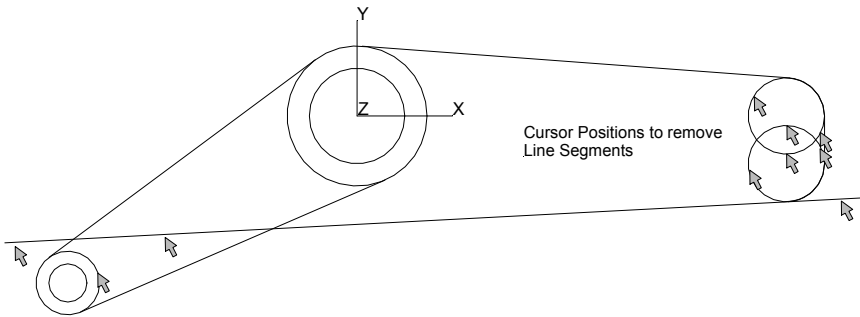

**Picture 2-7**

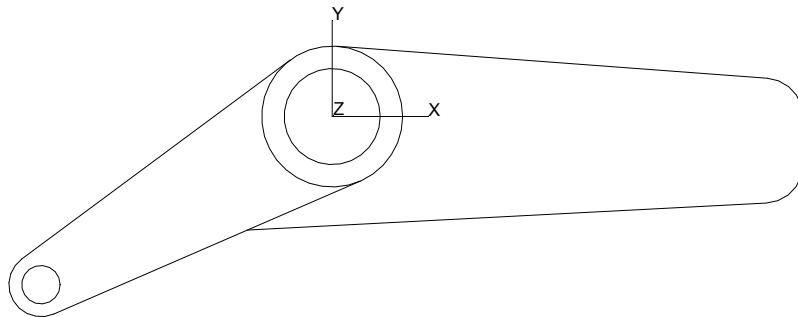

**Picture 2-8**

## CREATING LINE AT ANGLE

The next step is to define a line that lies tangential to the R22 circle at an angle of 3 degrees to the X-axis.

1. Select the “Line At Angle” button.



Line at Angle

2. Click the X-axis coordinate system handle with the mouse to define the reference axis for the angle.

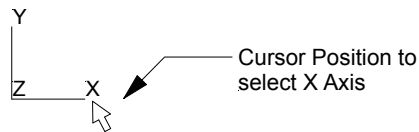

3. Type “3” in the “A” field of the Value Entry Box (Do not press ENTER).
4. Select the “Tangency” button.



Tangency

5. Move the cursor to a position slightly below the R22 circle as shown in **Picture 2-9**. The geometry preview will show the new line. If it is OK confirm the action with a mouse click.

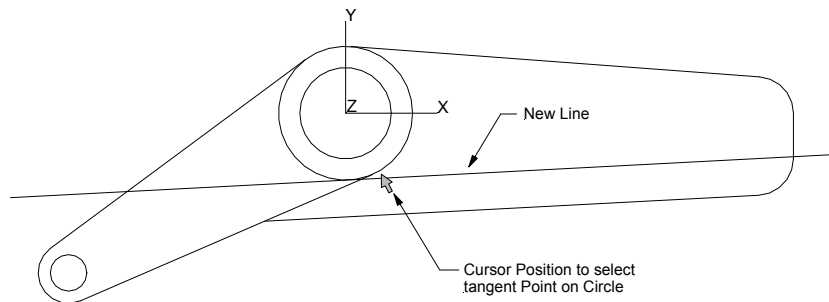

**Picture 2-9**

## CREATING A CORNER FILLET

Now we're going to create a corner fillet between two lines meeting below the R22 radius circle.

1. Click the "Corner Fillet" button.



Corner Fillet

2. When the Value Entry Box prompts for a radius value, type "40" in the "R" field.
3. At the "Pick int. of two lines, arcs or circles" prompt, move the cursor to the inside of the intersection between the two lines as shown in **Picture 2-10**. Pausing the mouse over the corner without clicking, the dynamic preview will show the fillet to be inserted. Clicking there will actually insert the fillet.

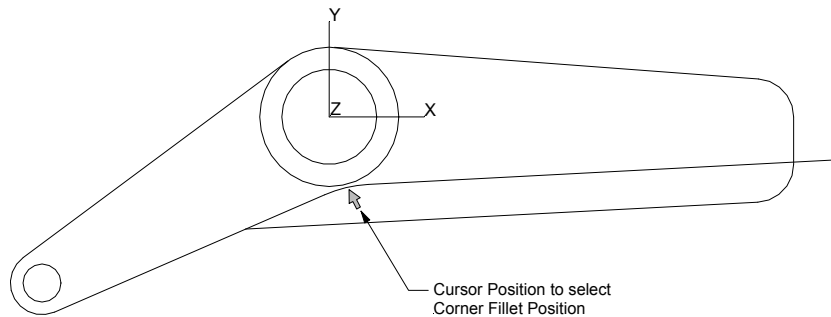

**Picture 2-10**

## DEFINING PARALLEL LINES

Now we will create some help geometry to find the center of the R10 circle 70mm to the right of the part origin. First we define a line that lies parallel to the Y-axis at a distance of 70mm. Then we create a line with a distance of 10mm to the 3° angled line starting at the R40 corner fillet in the lower part of the geometry.

1. First select the “Line , Parallel” button.



Line, Parallel

2. For the parallel distance type “70” in the “D” field of the Value Entry Box. (Do not press ENTER).
3. Move the cursor to the right side of the systems Y-axis coordinate handle as shown in **Picture 2-11**. The geometry preview will show you a line parallel to the Y-axis with a distance of 70mm. If the preview is OK confirm with a mouse click.

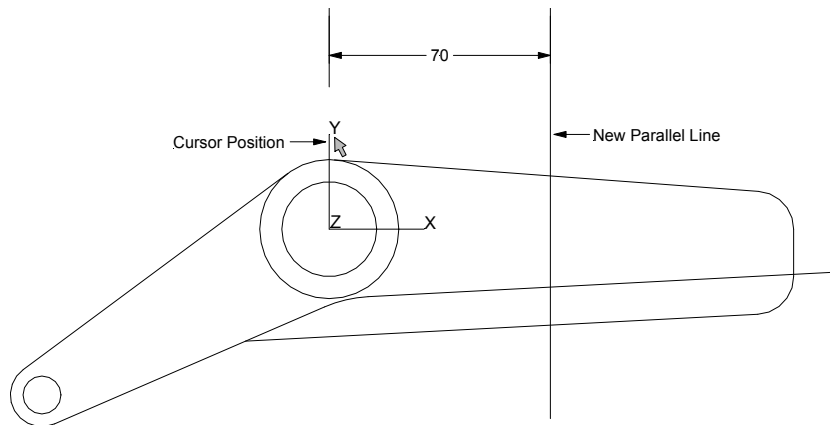

**Picture 2-11**

4. For the second parallel line type “10” in the “D” field of the Value Entry Box. (Do not press ENTER).
5. Move the cursor to a position below the 3° line as shown in **Picture 2-12**. The geometry preview will show you the new parallel line with a distance of 10mm to the selected line. If the preview is OK confirm with a mouse click.

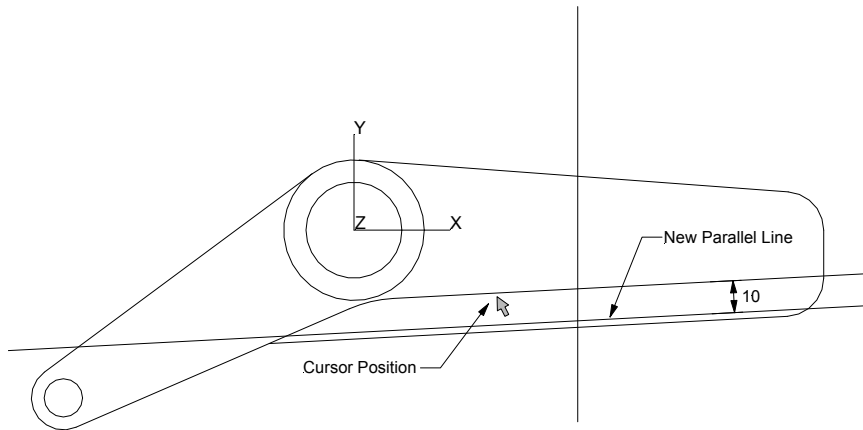
**Picture 2-12**

## DEFINING CIRCLE

Next step is to define the R10 circle at the intersection of the newly created parallel lines (help-geometry) by specifying its radius and center location.

1. Select the “Circle/Arc, Center, Radius” button and the “Snap All” pick mode.



Circle/Arc, Center, Radius



Snap All

2. For the Radius type “10” in the “R” field of the Value Entry Box.
3. Move the cursor to the intersection of the two parallel lines like shown in **Picture 2-13**. The geometry preview will show you a circle moving on the screen along with your mouse cursor. When the software snaps to the correct position and the preview is OK confirm with a mouse click to create the circle.

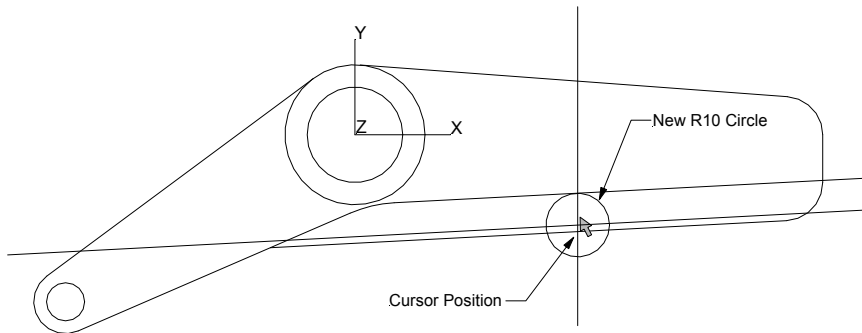

**Picture 2-13**

## DELETING ELEMENTS

Next we delete the two parallel lines we just created to get the circles center location.

1. Click the “Delete” button. This command allows you to delete elements.



Delete

2. Check that the “Verify” mode button is pressed (set to “On”). When a group command like “Delete” is selected, the “Verify Off” (button up) mode executes the command immediately after you select an entity. The “Verify On” mode (button down), highlights each of the entities as you select them and does not execute the command for these entities until you click the ENTER button. This allows you to select more than one entity and to verify your selections.



Verify Mode

3. Select the two lines as shown in **Picture 2-14** and press the ENTER button to delete them.



Inadvertently selected elements can be deselected with a mouse-click (selecting same entity again).

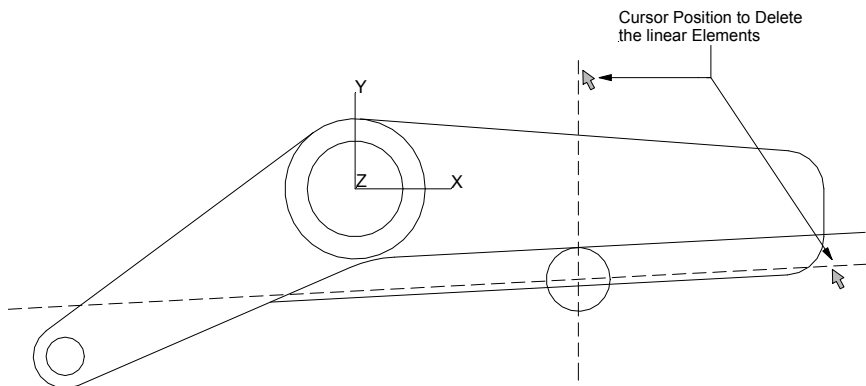

**Picture 2-14**



## DEFINING TANGENTIAL ARC

Follow these steps to create the R10 arc that fills the corner of the existing R10 circle and the angled line. This is accomplished by specifying the radius and two points that lie tangential on both elements. For the result see **Picture 2-15**.

1. Select the “Circle/Arc, Two Points, Radius” button.



Circle/Arc, Two Points, Radius

2. Select the “Finite Mode“ option located in “Geometry” menu. For all Circle/Arc commands, “Finite Mode” OFF creates circles, ON creates arcs. When selected you will see a small checkmark in the menu indicating the option is activated. Every selection of this menu entry toggles the finite mode “On” or “Off”.

! Do not forget to “uncheck” this option after the arc has been created !

3. For the Radius type “10” in the “R” field of the Value Entry Box.

4. Select the “Tangency” button.



Tangency

5. Move the cursor to the right side of the existing R10 circle as shown in Picture 2-15 and click the mouse. The circle will be displayed in dotted style after being selected. Now move the cursor to a position slightly above the angled line. The geometry preview will show the new arc when moving the cursor to this position. Confirm the action with a mouse click. See **Picture 2-15** for the result.

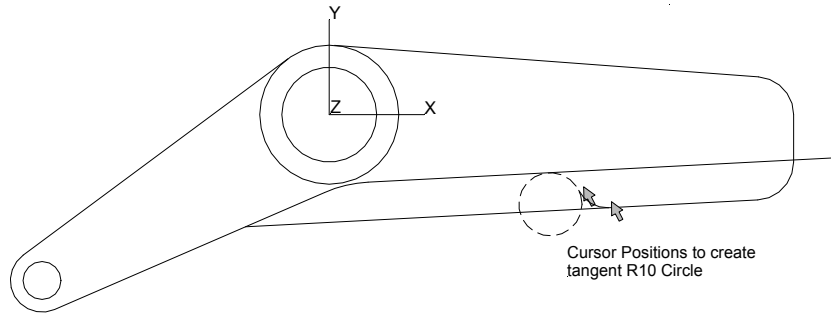
**Picture 2-15**

### REMOVING LINE/ARC SEGMENTS

Follow the instructions below to remove some parts of the geometry to clean up and finish the outside profile of the part.

1. Click the "Remove to Closest" button. This command will allow you to remove a segment of a line, arc, or circle between the closest boundaries.



Remove to Closest

2. At the "Pick Line, Arc or Circle" prompt, select the line and arc segments to be removed until the result appears as in **Picture 2-16**.

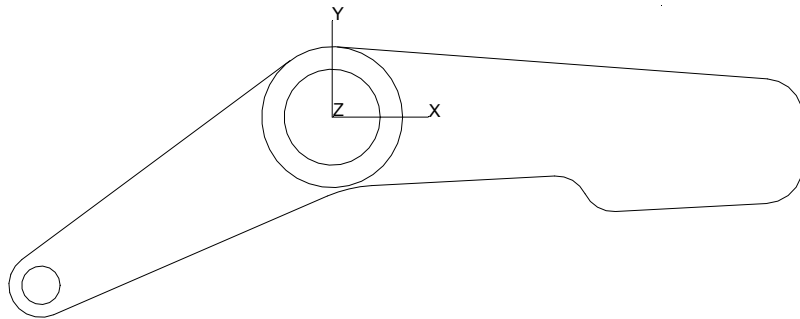
**Picture 2-16**

## DEFINING PARALLEL LINES

Now we continue with creating the pocket on the right side. First we need two parallel lines with a distance of 3mm to the existing angled lines. In addition we also need a line offset 60mm to the right of the Y-axis.

1. First select the “Line Parallel” button.



Line, Parallel

2. For the distance type “3” in the “D” field of the Value Entry Box. (Do not press ENTER).
3. Move the cursor to the POS #1 slightly above the angled line as shown in **Picture 2-17**. The geometry preview will show you a parallel line at a distance of 3mm. If the preview is OK confirm with a mouse click. Repeat the same at POS #2.
4. Now type “60” in the “D” field of the Value Entry Box (Do not press ENTER).
5. Move the cursor to the right side of the systems Y-axis coordinate handle as shown in **Picture 2-17**. The geometry preview will show you a line parallel to the Y-axis with a distance of 60mm offset to the right side. Confirm with a mouse click if the preview is OK.

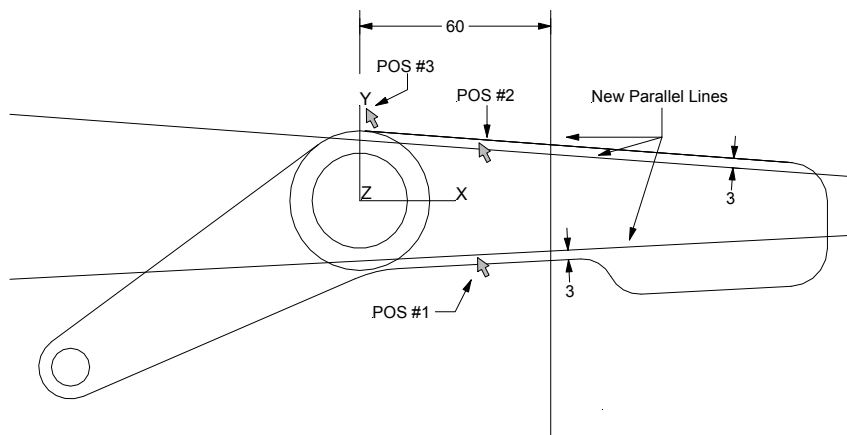

Picture 2-17

## CREATING CORNER FILLETS IN POCKET

Now we're going to create corner fillets inside the right pocket.

1. Click the "Corner Fillet" button.



Corner Fillet

2. When the Value Entry Box prompts for a radius value, type "6" in the "R" field.
3. At the "Pick int. of two lines, arcs or circles" prompt, move the mouse to the four positions shown in **Picture 2-18**. The dynamic preview will show the fillet to be inserted. Clicking there will actually insert the fillet.

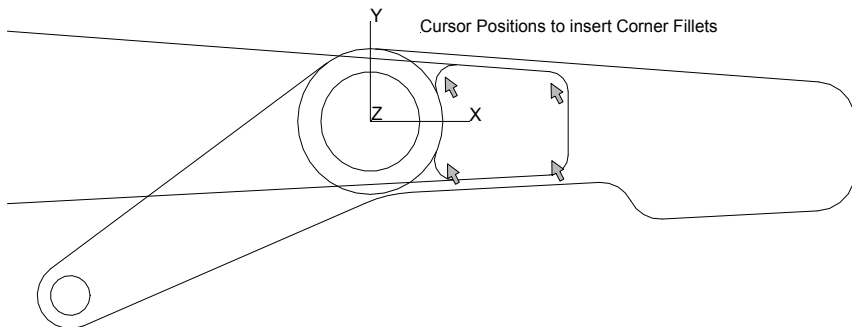

**Picture 2-18**

## REMOVING (TRIM) LINE SEGMENTS

Follow the instructions below to remove some parts of the geometry to clean up the right pocket profile.

1. Click the “Remove to Closest” button. This command will allow you to remove a segment of a line, arc, or circle between the closest boundaries.



Remove to Closest

2. At the "Pick Line, Arc or Circle" prompt, select the line and arc segments to be trimmed until the result appears as in **Picture 2-19**.

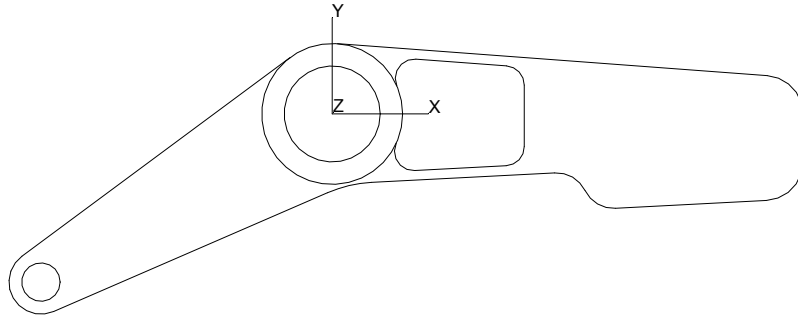

**Picture 2-19**

## DEFINING PARALLEL LINES

Now we continue with creating the pocket on the left side of the part. Again we need two parallel lines with a distance of 3mm to the existing angled lines.

1. First select the “Line Parallel” button.



Line, Parallel

2. For the distance type “3” in the “D” field of the Value Entry Box. (Do not press ENTER).
3. Move the cursor to the POS #1 slightly above the angled line as shown in **Picture 2-20**. The geometry preview will show you a parallel line at a distance of 3mm. If the preview is OK confirm with a mouse click. Repeat the same at POS #2.

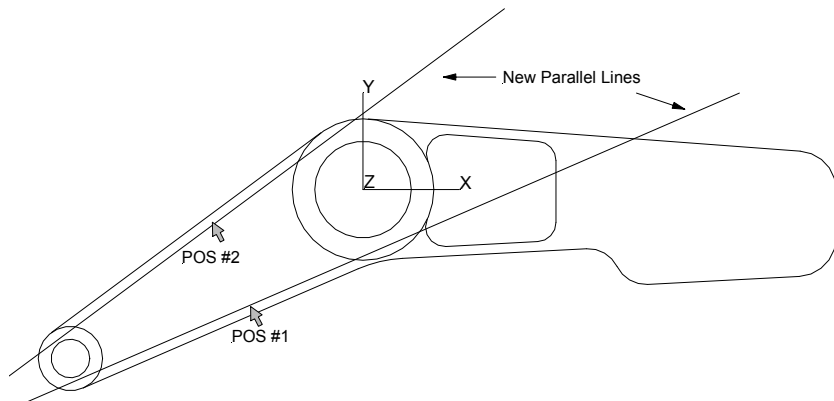

**Picture 2-20**

## CREATING LINE AT ANGLE

For the lower pocket boundary we need a line angled at 30 degrees to the Y-axis with a distance of 80mm to the part origin as shown in **Picture 2-21**.

1. Select the “Line At Angle” button.



Line at Angle

2. Click the Y-axis coordinate system handle with the mouse to define the reference axis for the angle.

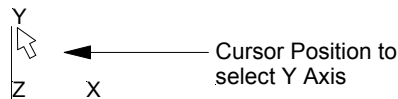

3. Type “30” in the “A” field of the Value Entry Box (Do not press ENTER).
4. To define the point through which the angled line will move we select the “Polar Mode” option located in “Edit /Point Picking” menu. When selected you will see a small checkmark in the menu indicating the option is activated. Every selection of this menu entry toggles the polar mode “On” or “Off”. Do not forget to toggle the “Polar Mode” to “OFF” condition when finished.



Polar Mode

5. The content of the Value Entry Box will change as shown below. Input “-150” (“210” also possible) in the “A” field as the polar angle and “80” in the “R” field as the polar radius to specify the point for the angled line. Then press the ENTER button to create the new line. See **Picture 2-21** for the result.

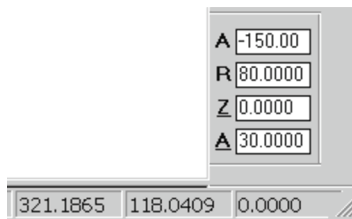

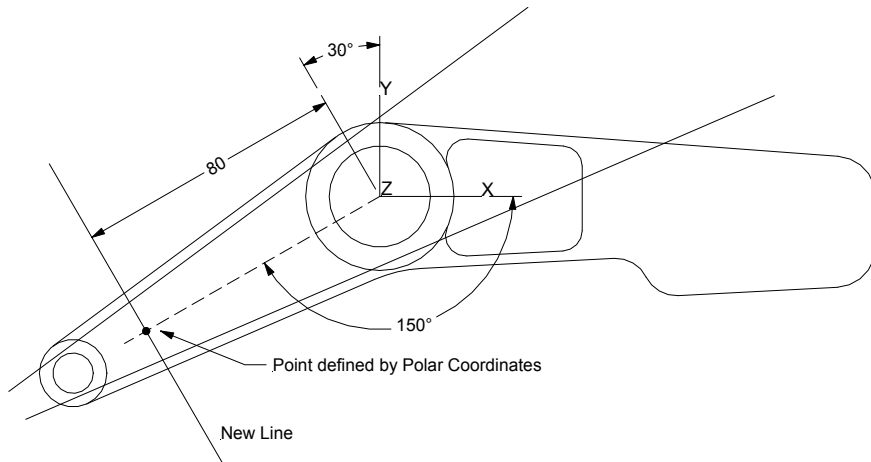
**Picture 2-21**

### CREATING CORNER FILLETS IN POCKET

Now we're going to create the corner fillets inside the left pocket.

1. Click the "Corner Fillet" button.



Corner Fillet

2. When the Value Entry Box prompts for a radius value, type "6" in the "R" field.
3. At the "Pick int. of two lines, arcs or circles" prompt, move the mouse to the positions shown in **Picture 2-22**. The dynamic preview will show the fillet to be inserted. Clicking there will actually insert the fillet.



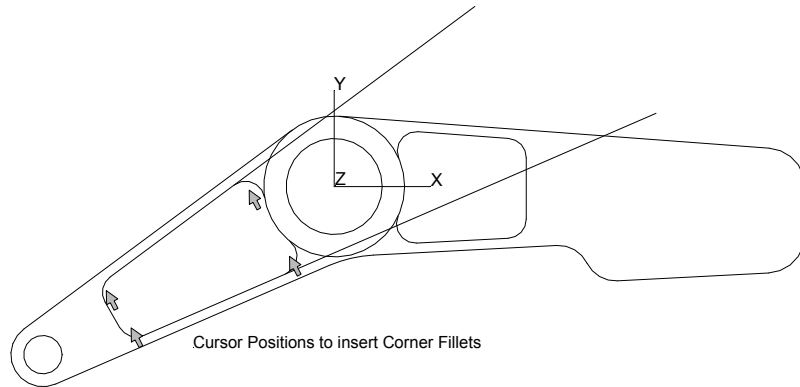

**Picture 2-22**

### REMOVING (TRIM) LINE SEGMENTS

Follow the instructions below to clean up the left pocket profile.

1. Click the "Remove to Closest" button. This command will allow you to remove a segment of a line, arc, or circle between the closest boundaries.



Remove to Closest

2. At the "Pick Line, Arc or Circle" prompt, select the line and arc segments to be trimmed until the result appears as in **Picture 2-23**.

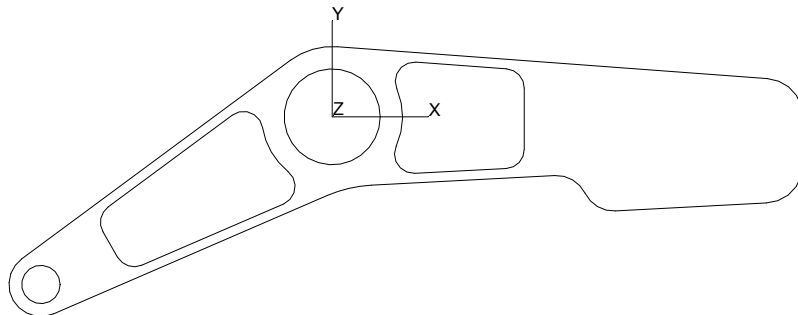

**Picture 2-23**



The following two topics explain how to import and move geometry from a CAD source by loading a DXF file. If you have already created the geometry by following the previous topics please jump to the “Creating the Boundary Rectangle” topic to add the frame needed as the pocket boundary for roughing the outside profile.

### IMPORT CAD DATA (LOADING DXF FILE)

This section shows how to import and arrange CAD data to be machined with EZ-Mill. As an example we will import a CAD file in DXF format. The file named “MILL-TUTORIAL.DXF” was copied to your computer by the setup program and is located in the “EZCAMW \ MILLPARTS” folder.

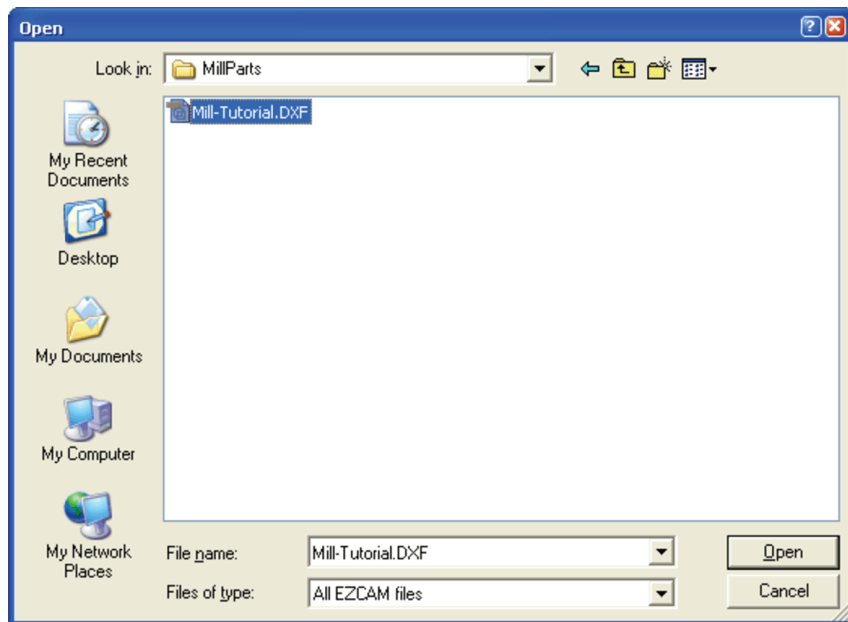

Picture 2-24

1. Select “Open” command from the “File” menu to open the file dialog. In **Picture 2-24** you can see the dialog displayed on a Windows XP professional workstation system. This dialog may vary according to the version of the Windows™ operating system running on your machine.
2. Select the folder “EZCAMW \ MILLPARTS” on the drive where you installed the software
3. In the ”Files of Type” list select “AutoCAD (\*.DWG; \*.DXF)”.
4. Select the file “MILL-TUTORIAL.DXF” and click the “Open” button. The imported geometry should appear as in **Picture 2-25**.

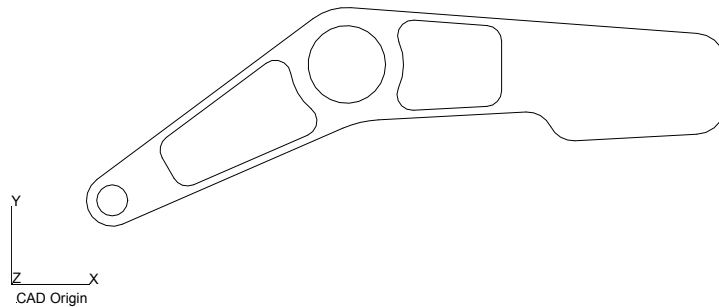

Imported DXF geometry

**Picture 2-25**



If possible, remove all unnecessary geometry, views, dimensions, etc. from the drawing in the CAD system before exporting data in DXF or other exchange format. This will reduce file size and amount of work necessary to remove these entities within EZ-Mill.

## MOVING IMPORTED DATA

**Picture 2-25** shows the imported CAD geometry. You can see that the origin is different to what we need (see “Selecting an Origin for the part” section at the beginning of the tutorial). Therefore we will show you how to move the geometry so that the work origin is in the center of the 30mm DIA. circle.

1. Click the “Move” command from the “Edit” menu. This command allows you to move selected elements by defining initial and target position (from..→ to..).
2. Check that the “Verify” mode button is pressed (set to “On”).



Verify Mode

3. At the “Pick from Point” prompt select the “Center Circle” pick mode and click the Dia.30mm circle as shown in **Picture 2-26** (POS #1) in order to select the center point as the “Initial Point”.



Center Circle

4. At the “Pick to Point” prompt select the “Snap All” pick mode and click the origin of the “World” coordinate system (POS #2) as the “Target Point”.



Snap All

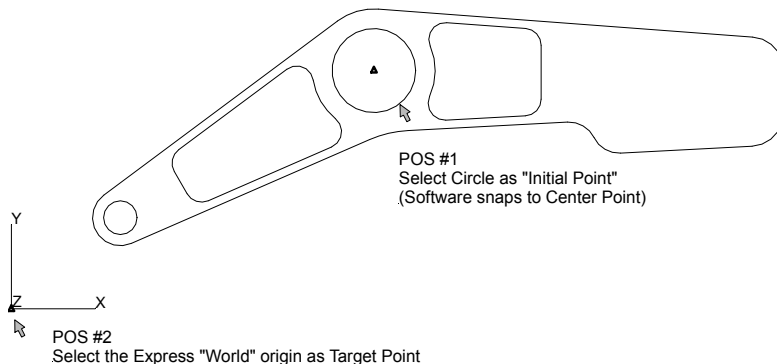

**Picture 2-26**

5. Click the “Select All” command from the “Edit” menu. This command will select all existing elements in the view port. Then press the ENTER button. The geometry is moved to the new location as shown in **Picture 2-27**.

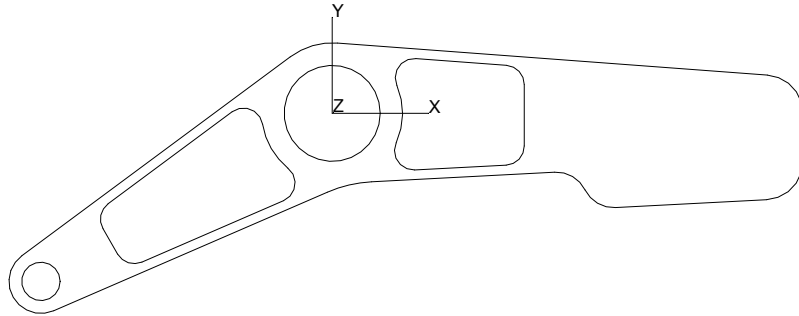

**Picture 2-27**

### CREATING THE BOUNDARY RECTANGLE

The last thing to do is to create a rectangle that will later serve as the pocket boundary for the first Work Step where the outside profile will be rough machined.

1. Select the “Rectangle, Corner to Corner” command from the geometry menu. This will allow you to create a rectangle by defining two opposite corner locations.
2. For the first position type “-110” in the “X” field of the Value Entry Box. Use the TAB button to switch to the “Y” field and type “30”. Then press ENTER to verify the first position.
3. To define the second position use the TAB button to select the “X” field again and type “160”. Continue to the “Y” field and type “-70”. Make sure that the “R” and “Z” values are set to “0”. Then press ENTER. The result should appear as in **Picture 2-28**.

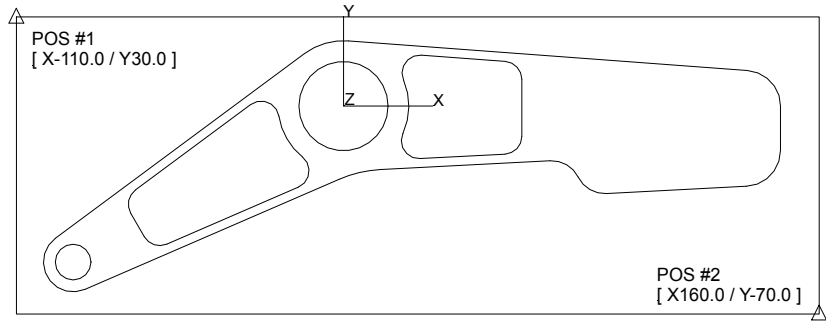

**Picture 2-28**



If you want to save the newly created geometry before continuing, jump to the “Save Part Program” section at the end of the tutorial.

## THE PATH CURVES

Before we continue with the path curve creation we will give you a short explanation about what a path curve is. Each Work Step needs a profile or shape the tool follows in some way. Therefore a path (curve) has to be assigned to every Work Step following certain rules determined by the selected machining cycle (Contour, Pocket, Drilling, etc.). For example it is allowed to define an open path when using the “Contour” feature, whereas a “Pocket” path always has to be closed.

As any path is represented by curves within EZ-CAM it is important to know that the software makes use of the curve entity in several different ways. It can be used as a simple tool path for contouring, as a machining boundary to define a pocket or an island, or it may be used to define a surface (Mill / Mill-Pro levels only). All of these uses for the curve make it a very flexible and powerful feature. For example you can create multiple Work Step's to machine the same curve for roughing and finishing or Spot-Drilling with subsequent Drilling operations.

A curve can be a straight line, an arc, a spline, or a combination of these things. It may include "rapid" moves, or it may be a single point. The curve does not have to follow any specific rules on its own, but as mentioned above, certain rules determined by the desired operation and the selected machining cycle have to be followed.

### **For this tutorial we have to create 5 Curve entities:**

1. Boundary curve (rectangle) representing the outside boundary when roughing the part (leaving 0.2mm stock allowance for finishing).
2. Contour curve for the parts outside shape
3. Pocket curve 1 for the circular pocket
4. Pocket curve 2 including the left and right side pockets
5. Drilling curve representing the 12mm DIA hole position



You will have to assign a unique ID to each curve that is created. Use your own ID's or the systems default (Crv1, Crv2, etc.). When working on extensive projects it is always good to use ID's that can be easily remembered and that reflect the purpose of the curve.

#### **Important !**

Don't use space or any other special characters in the curve ID.

## POCKET PATH CREATION RULES

This tutorial uses “Pocket” and “Zig-Zag” cycles for roughing of the outside and inside pocket profiles. Below you find a list of the most important rules to be followed when creating curves to be used in conjunction with one of these cycles.

- “Pocket” and “Zig-Zag” cycles always need a closed boundary curve (same start & endpoint).
- The boundary may start with a rapid move to define the plunge location.
- No rapid move within the boundary profile itself is allowed.
- If a pocket contains any islands, there are two ways to define these:
  - ❶ Include boundary and islands in one single curve. The islands are directly appended to the boundary curve by rapid moves. Boundary and all island profiles have to be closed shapes.

The element sequence of a curve including boundary and 2 islands follows.

[Boundary Profile](#) -> [Rapid Move](#) -> [Island1](#) -> [Rapid Move](#) -> [Island 2](#)

- ❷ Create separate curves for boundary and islands. When creating the Work Step later, select the boundary curve in the “Path ID” list box and all islands in the “Check Curves” table. The result will be the same as mentioned before but the advantage is that there is no need to define different curves for rough and finishing operations.

The tutorial will make use of the second method creating separate curves for boundary and island profiles.

- A circular boundary or island must contain at least three points (two arc elements).



See the EZ-Mill Help for more information about “Pocket“ paths.



## CREATING THE BOUNDARY CURVE

For the first rough machining operation we need a curve that represents the pocket boundary. We will use the existing geometry rectangle to define the curve.

1. First we have to create a new curve. Therefore select the “New” command from the “Curves” menu or click the corresponding button. In the dialog that opens type “Boundary” as the new ID and confirm with OK.



New

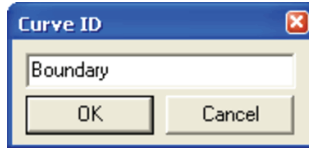

2. To define the boundary profile we use the “Chain” option. Select the “Chain” command from the “Curves” menu or click the corresponding button.



Chain

3. The prompt “Select First Line or Arc” is displayed at the bottom edge of the window. Move the cursor to Position as shown in **Picture 2-29** and double-click the mouse to select the line as the first element in the curve chain. The software automatically completes the curve by following the connecting geometry elements from the first point to the last.

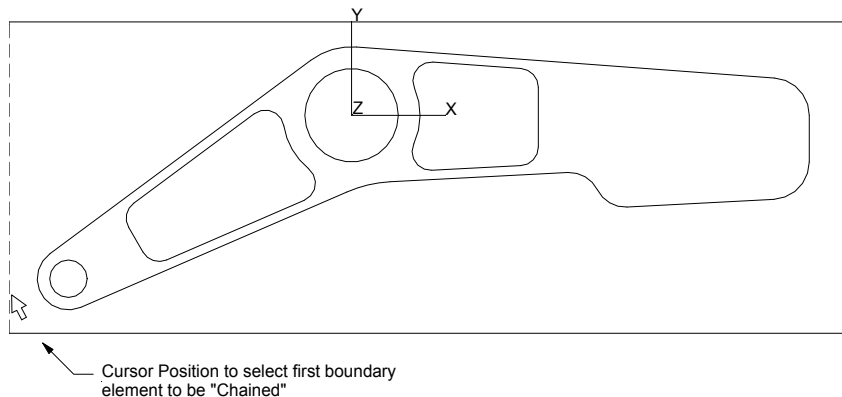

**Picture 2-29**

The position where the first element is selected is very important to the direction of the curve. The items between the selected elements are automatically completed by the software and displayed as shown in **Picture 2-30**. A small arrow referred to as the “direction indicator” shows the path direction.

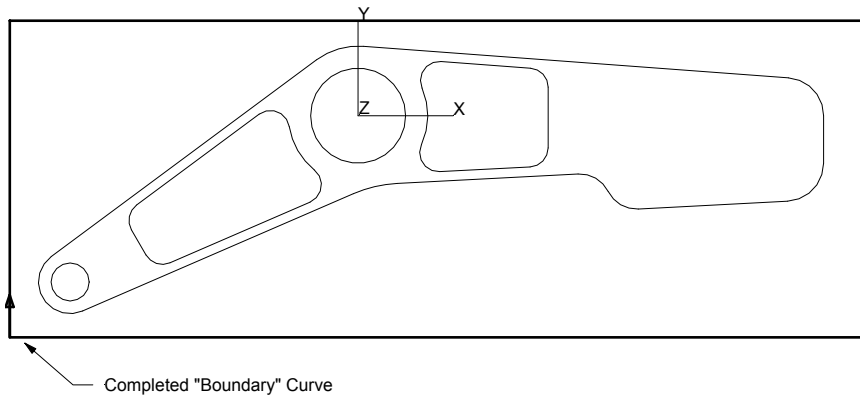

**Picture 2-30**

### CREATING THE CONTOUR CURVE

Now we create the curve that represents the outside profile of the part. This curve will later be used as island for roughing and as contour curve for the finishing Work Step.

1. Select the “New” command from the “Curves” menu or click the corresponding button. In the dialog that opens type “ODContour” as the new ID and confirm with OK.



New

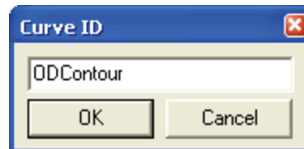

2. Select “Chain” from the “Curve” menu or click the corresponding button. Move the cursor to Position as shown in **Picture 2-31** and double-click the arc near by its start point to select this entity as the first element in the curve chain. The software automatically completes the curve resulting in a clockwise direction as shown in **Picture 2-32**.



Chain

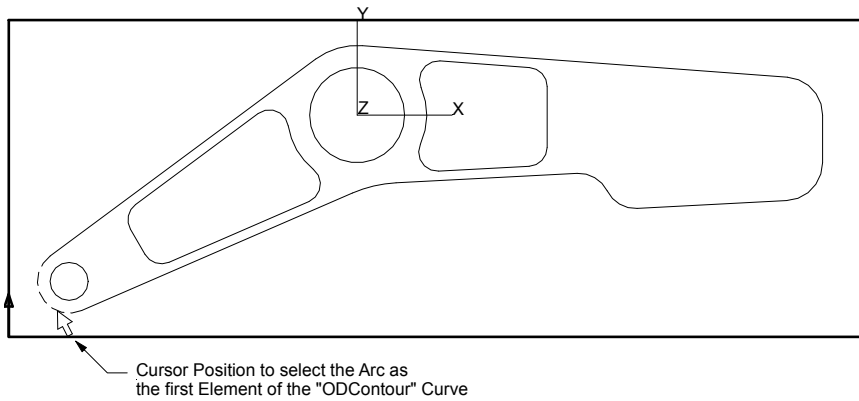

Cursor Position to select the Arc as the first Element of the "ODContour" Curve

Picture 2-31

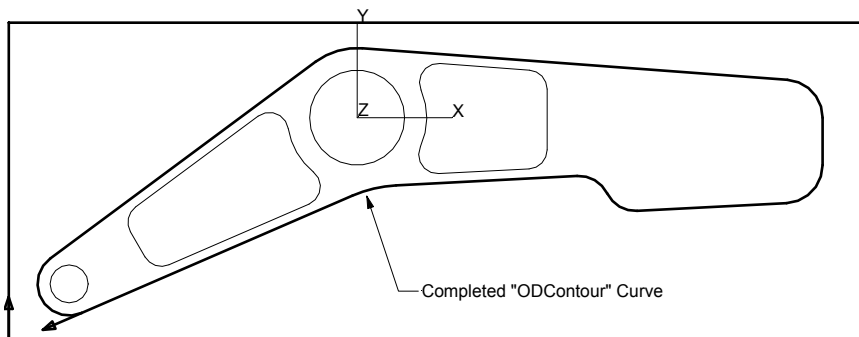

Completed "ODContour" Curve

Picture 2-32

## CREATING THE POCKET1 CURVE

Next comes the creation of the curve representing the circular pocket.

1. Select the “New” command from the “Curves” menu or click the corresponding button. In the dialog that opens type “Pocket1” as the new ID and confirm with OK.



New

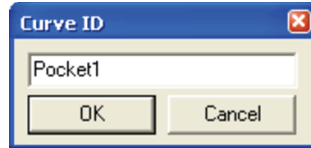

2. Select “Chain” from the “Curve” menu or click the corresponding button. Move the cursor to Position as shown in **Picture 2-33** and double-click the arc. The software automatically creates a circular curve in counter-clockwise direction with the start at the 0 degree position. The result is shown in **Picture 2-34**.



Chain

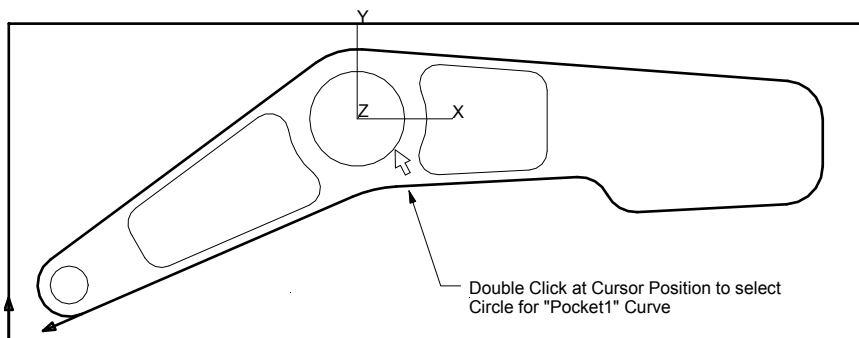

Picture 2-33

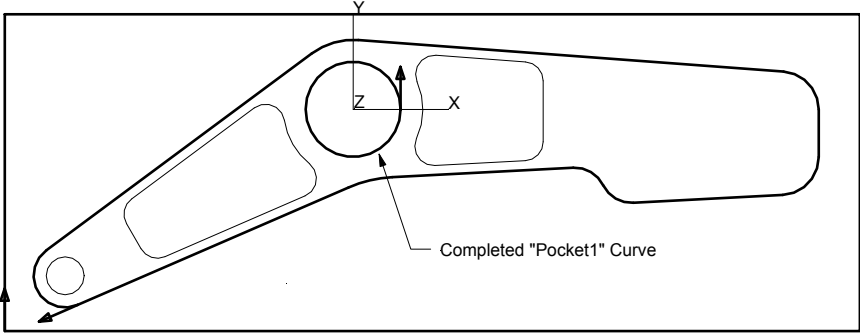

Picture 2-34

## CREATING THE POCKET2 CURVE

Since the remaining two pocket profiles will later be machined using the same tool, technology and machining parameters, we will combine these two shapes into one single curve. The connection is achieved by a rapid link that is inserted automatically by the software when the “Chain” command is used multiple times on independent profiles. You will also learn how to control the start/end point of the curve as well as the curve direction. This is very important because both chained profiles need to have the same direction if combined into one single curve.

1. Select the “New” command from the “Curves” menu or click the corresponding button. In the dialog that opens type “Pocket2” as the new ID and confirm with OK.



New

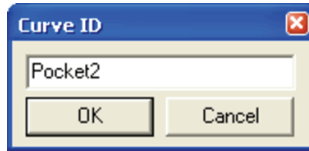

2. Select “Chain” from the “Curve” menu or click the corresponding button. Then move the cursor to the “Pocket A” profile and double-click anywhere along this contour (see **Picture 2-35**). Do the same anywhere along the “Pocket B” contour. The system automatically chains all elements and connects both pocket profiles using a rapid move represented by a dotted line between the start points of each of the two profiles. Don’t worry about correct start point and curve direction, as we will take care of that in the next step.



Chain

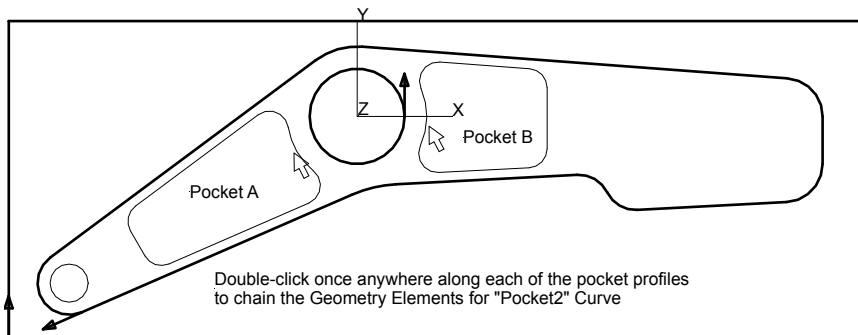

**Picture 2-35**

3. In the following step we are going to define the start/end point for both profiles in the “Pocket2” curve. First select “Start/End” from the “Curve” menu, then switch to the “Midpoint” pick mode from the “Edit/Point Picking” menu. If you now move the cursor along the existing “Pocket2” curve profiles the dynamic preview automatically snaps to the next possible midpoint that can be selected. Click at positions #1 on “Pocket A” and #2 on “Pocket B” as shown in **Picture 2-36**. Make sure to click on the inside of the profiles. See **Picture 2-36/2** for the result.



Start/End



Pick Midpoint

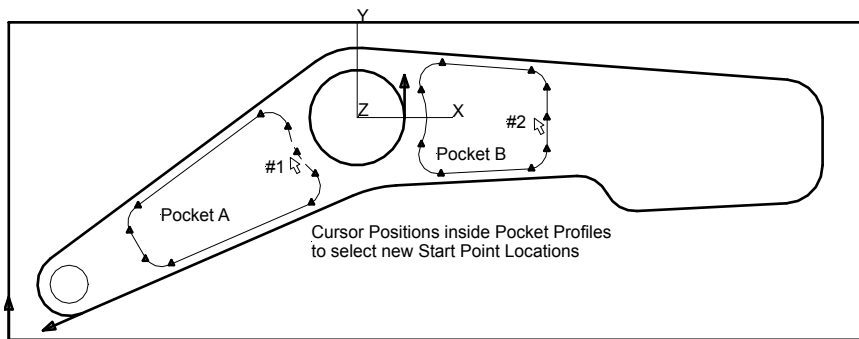

Picture 2-36

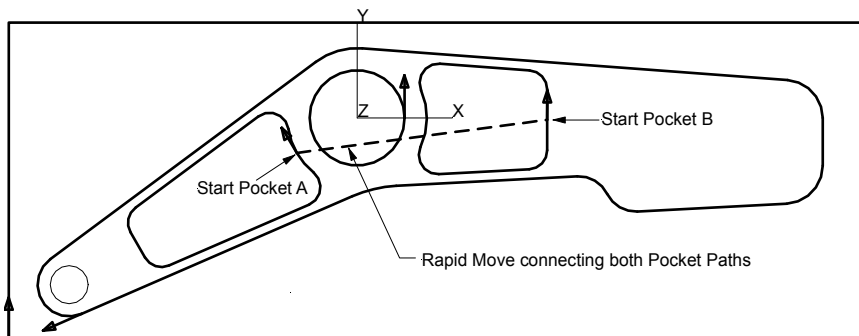

Picture 2-36/2



The Start/ End curve command is only applicable to existing curves that represent closed profiles. It actually combines several important tasks into one single command.

### **1. Move the Start/End point of existing curve**

In combination with one of the available “Pick” modes it is possible to select any point (endpoint, midpoint, etc) along the existing curve profile as the new start/end location.

### **2. Specify Curve direction**

If the cursor is positioned inside the closed profile then the curve direction is automatically set to counter-clockwise. If outside then direction is clockwise. If necessary this can later be changed by using the “Reverse Direction” command from the “Curves” menu.

### **3. Insert Rapid Move (Plunge Point Location)**

If the specified start/end location is not lying on the curve itself the system will insert a perpendicular rapid move connecting the selected position with the profile. This is later used as plunge position by the “Zig-Zag” and “Pocketing” cycles.



## CREATING THE 12MM HOLE CURVE

Finally the last curve to be created defines the 12mm DIA hole position.

1. Select the “New” command from the “Curves” menu or click the corresponding button. In the dialog that opens type “Drill12” as the new ID and confirm with OK.



New

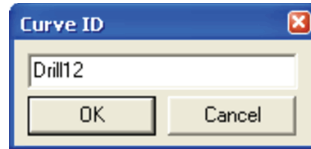

2. To create the path click the “Linear” button or select the command in the “Curve” menu.



Linear

3. Next select the “Center Circle” pick mode and move the cursor to the position as shown in **Picture 2-37** in order to define the center coordinates. The geometry preview will help you as it automatically snaps to the center when moving the cursor on the existing circle. Click the mouse to select the position. The finished path is displayed in form of a small triangle as shown in **Picture 2-38**.



Center Arc / Circle

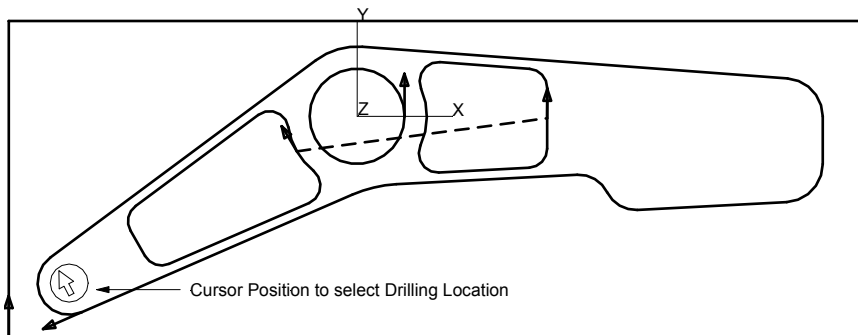

**Picture 2-37**

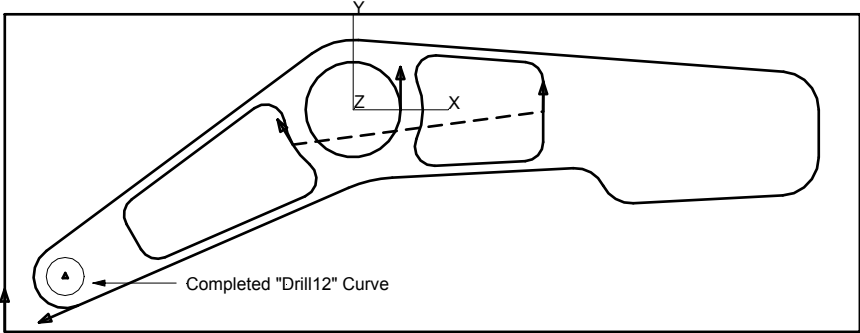

Picture 2-38

## CREATING THE PART PROGRAM

Now as the curves for the sample part are created we continue with the definition of the Work Steps that are necessary to machine the part. Every Work Step is created by selecting a cycle (Contour, Pocket, Drilling, etc.), specifying associated tool settings / machining parameters and assigning a curve that will be machined. Verifying the calculated tool path assures correct tool operation. Finally, when all necessary Work Steps have been defined the complete part program can again be visually checked using the 3D solid simulation. If everything works fine you can continue to the next step and create the CNC-Code.



Execution of the Work Steps will be in the same order they have been created. You can use the integrated spreadsheet to perform operations such as moving, reordering or deleting existing Work Steps.

See the “Spreadsheet” book in the online help for more detailed information.

The Part Program section of the EZ-Mill tutorial contains all Work Steps that are necessary to machine the part.

### **The part program of the tutorial will consist of these 8 Work Steps:**

1. Zig-Zag “Face” machining to rough machine the outside profile leaving 0.2mm stock allowance for finishing.
2. “Pocket” machining of curve “Pocket1” leaving 0.2mm stock allowance for finishing.
3. “Pocket” machining of curve “Pocket2” leaving 0.2mm stock allowance for finishing.
4. Finishing (“Contouring”) the outside profile
5. Finishing (“Contouring”) Pocket1 (circular pocket)
6. Finishing (“Contouring”) Pocket2
7. Spot-Drill 12mm DIA hole
8. Drill 12mm DIA hole

## CREATING WORK STEP #1 (ROUGHING OUTSIDE PROFILE)

Now we create the first Work Step for rough machining the exterior profile using the “Zig-Zag” cycle. The result will be a pocketing type of machining using the rectangular geometry as the pocket boundary and the parts shape as an island. The tool moves extend over the specified boundary to clean up any remaining material. We will use a 14mm DIA end mill for machining up to the depth of 15mm, stepping down in increments of 5mm and leaving 0.2mm as finishing offset on the parts outside profile.

1. Select the “Work Step Data” command in the “Machining” menu to open the “Work Step Data” dialog. Once it is open switch to the “Tool Info” tab.

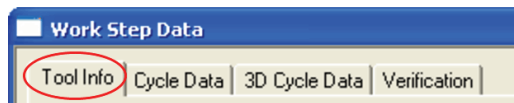

2. Press the “New” button and input “Face” as the new Work Step ID and confirm with OK.

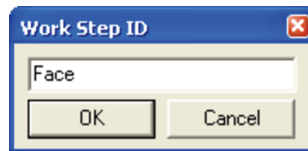

3. Select “Zig-Zag” from the cycle list and the “Boundary” curve from the Path ID list.

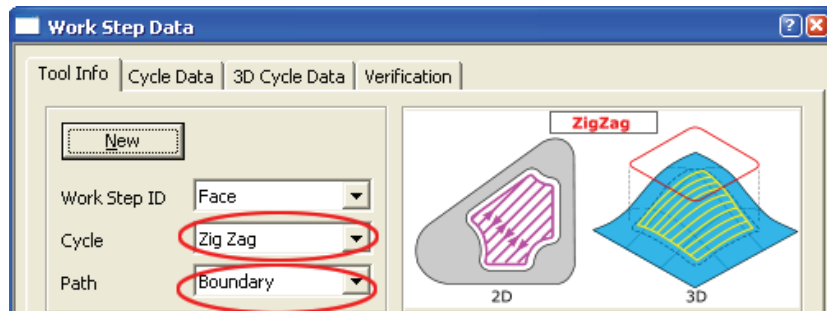

4. Input tool and technology settings to the appropriate fields as shown in **Picture 2-39**.

**Work Step Data**

Tool Info | Cycle Data | 3D Cycle Data | Verification

New

Work Step ID: Face

Cycle: Zig Zag

Path: Boundary

Tool Info

Select Tool ...

Tool ID:

Type: Flat

Material: HSS

Number: 1

Diameter: 14

Corner Rad: 0.0

Length: 0

Angle: 0

Comment:

Pitch (Tpi): 0.0

Flutes: 2

Comp #: 0.0

TLO #: 0

Fixture: 1

Cutter Comp: Off

Coolant: Mist

Tool Change

X: -150

Y: -150

Z: 150

Feeds & Speeds

Spindle RPM: 1200

Feed (X-Y): 150

Feed (Z): 75

First Feed: 15.0

Dwell: 0.0

Power (kW): 0

Material: ALUMAL14.MTL

Calculate

Change...

Z Data

Surface: 0

Rapid: 20

Clear: 2

Depth: 15

Step: 5

Step2: 0.0

Auto

Connect

Plunge Options...

User Variables... MCS ID: World

Save As Default Close

For Help select field and press F1

Diagram: Flat, Flat (+) Taper, Flat (-) Taper. D = Bottom Dia., L = Length, R = Corner Rad., A = Taper Angle.

**Picture 2-39**

5. Select the “Cycle Data” tab and make sure that the “Finish Pass”, “Face Milling”, “Minimize Jumps” and “Climb Milling” options are checked. . Input “0.2” to the “Stock Allow” field. This will result in 0.2 mm of material left on the contour to be removed later by the finishing Work Step. Input “5” as “Step Over” value for the “Zig-Zag” cycle. See **Picture 2-40**.

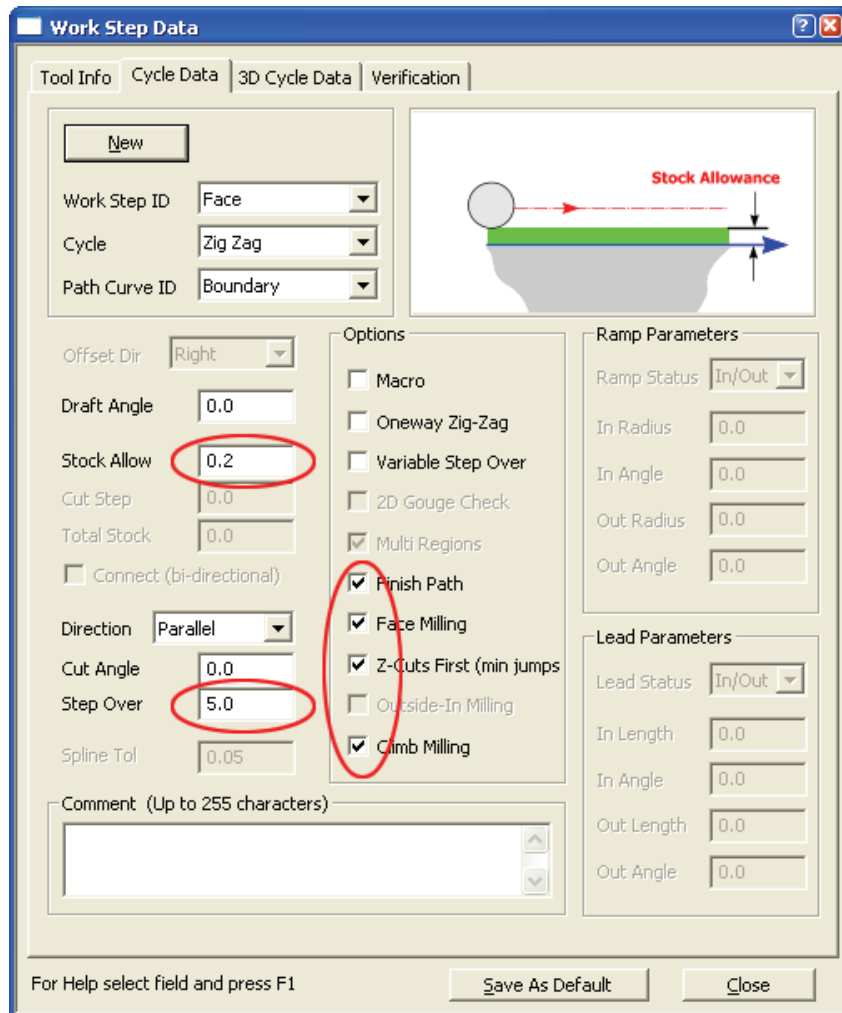

Picture 2-40

6. By the previous selection of the “Boundary” curve in the “Path ID” list, we only specified the outer border for the “Zig-Zag” cycle. As already mentioned one way to define islands is to directly append them at the end of the boundary curve. For this tutorial we will apply the second method by putting the “ODContour” curve to the “Check Curves” list. Therefore select the “3D Cycle Data” tab and press the “Add” button in the “Check Curves” section. On the dialog that opens select the “ODContour” curve from the list and continue pressing the “Add” button. Also note the “Fin Allow” automatically set to the same value as “Stock Allow” from the previous “Cycle Data” tab. Finally close the Work Step Data dialog using the “Close” button. See **Picture 2-41**.

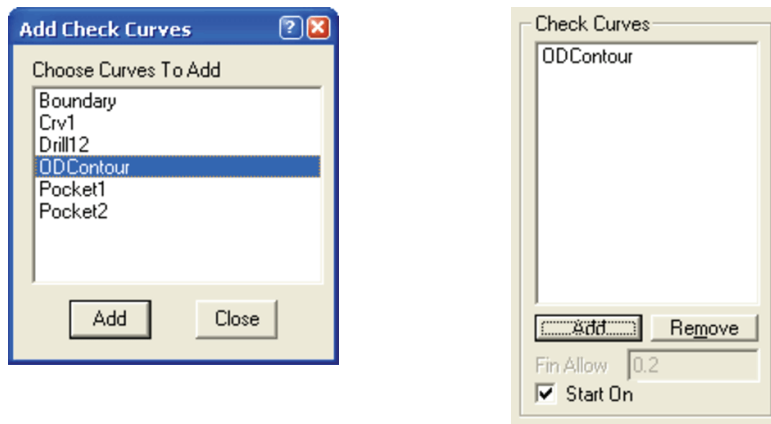

**Picture 2-41**

7. To ensure that the first Work Step was created correctly, it must be verified. Switch to “X-Y View” using the command button. Then click the “Verify” button. The system calculates the cutter path as shown in **Picture 2-42**.

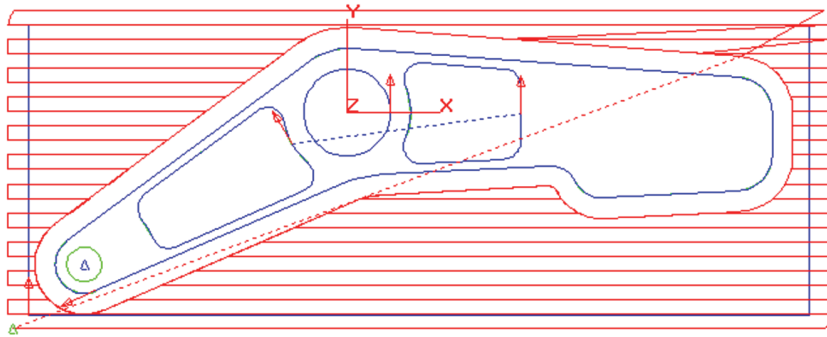
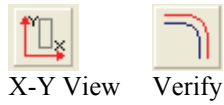

**Picture 2-42**

The first Work Step is now complete. Hit the “Redraw” button  to refresh the screen and remove the verified tool path display.



## CREATING WORK STEP #2 (ROUGHING CIRCULAR POCKET)

Next step is roughing the 30mm DIA circular pocket. We use the “Pocket” cycle with the same tool and machining settings as in the previous Work Step, leaving 0.2mm as finishing offset on the pocket profile.

1. Select the “Work Step Data” command in the “Machining” menu to open the “Work Step Data” dialog. Once it is open switch to the “Tool Info” tab.
2. Press the “New” button and input “RG-Pocket1” as the new Work Step ID and confirm with OK (“RG” as shortcut for “Rough”).

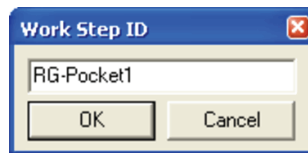

3. Select “Pocketing” from the cycle list and the “Pocket1” curve from the Path ID list.

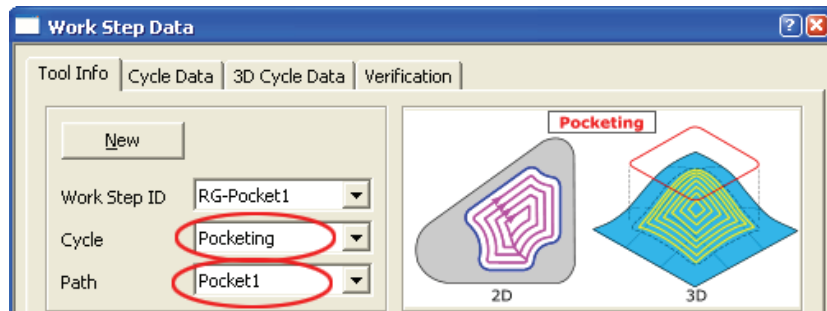

4. As tool and depth data remains the same we only need to set the “Feed (Z)” to a somewhat smaller value of “50”mm per minute since there is no pre-drilling and the tool is plunging directly into the pocket.
5. Switch to the “Cycle Data” tab and check that “0.2” as “Stock Allow” and “5” as “Step Over” value are set (should be ok from previous work Step). See **Picture 2-43**.

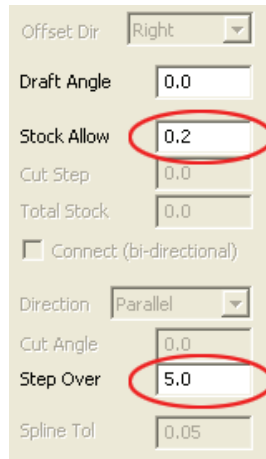

Picture 2-43

6. For Verification click the “Verify” button. The system calculates the tool path. Then you may use the “Simulate Tool” command to get a more realistic simulation of the tool movement as shown in **Picture 2-44**.



Verify



Simulate Tool

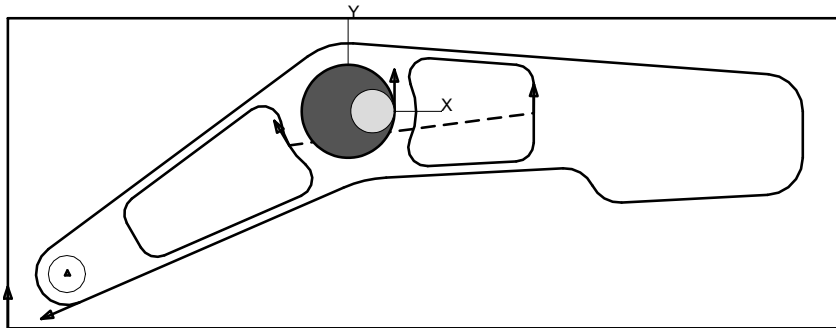

Picture 2-44

The second Work Step is now complete. Hit the “Redraw” button  to refresh the screen and remove the verified tool path display.

### CREATING WORK STEP #3 (ROUGHING INSIDE POCKETS)

Next step is roughing the two inside pockets. We use the “Pocketing” cycle with a 10mm DIA end mill to machine the pockets up to the depth of 5mm in one step leaving 0.2mm as finishing offset on the pocket profile. Both pocket boundaries have already been defined in the same curve reducing input and Work Step management because they are machined using identical parameters and settings.

1. Select the “Work Step Data” command in the “Machining” menu to open the “Work Step Data” dialog. Once it is open switch to the “Tool Info” tab.
2. Press the “New” button and input “RG-Pocket2” as the new Work Step ID and confirm with OK.

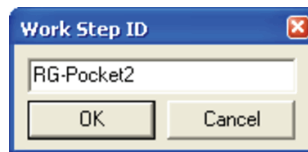

3. Select “Pocketing” from the cycle list and the “Pocket2” curve from the Path ID list.

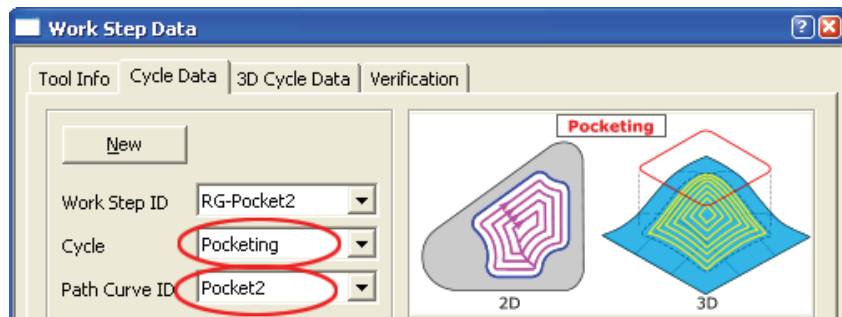

4. Input new tool and technology settings in the appropriate fields as shown in **Picture 2-45**.

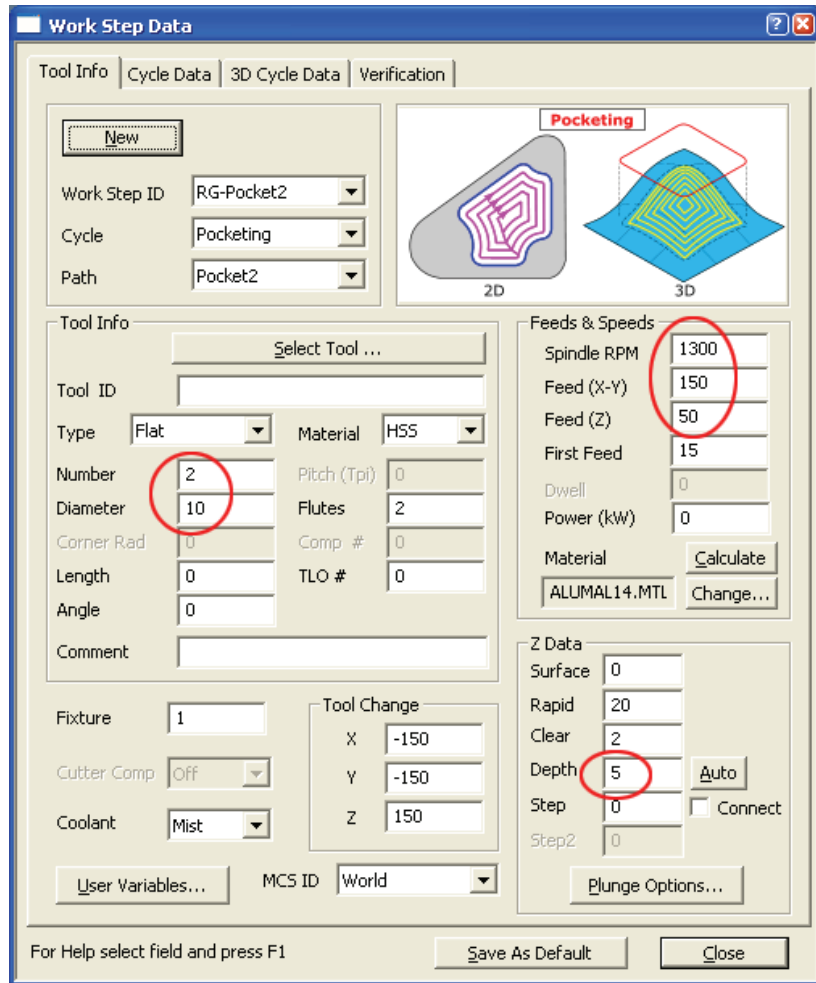

Picture 2-45

- Switch to the “Cycle Data” tab and check that “0.2” as “Stock Allow” and “5” as “Step Over” value are set (should be ok from previous work Step).
- For Verification click the “Verify” button. The system calculates the tool path. Then use the “Simulate Tool” command to get a more realistic simulation of the tool movement as shown in **Picture 2-46**.



Verify



Simulate Tool

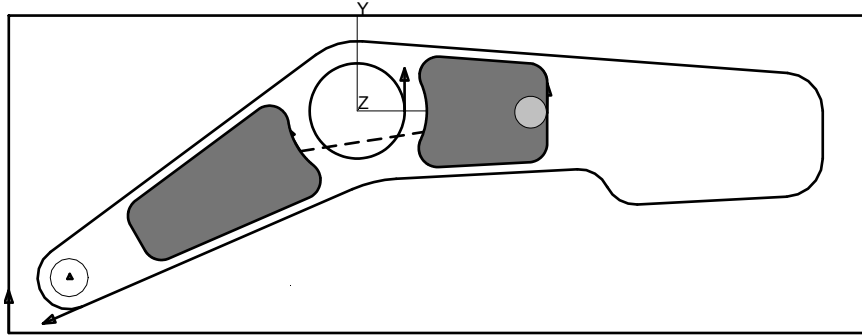

Picture 2-46

The third Work Step is now complete. Hit the “Redraw” button  to refresh the screen and remove the verified tool path display.

### CREATING WORK STEP #4 (FINISHING OUTSIDE PROFILE)

This Work Step will finish the outside profile in clockwise direction using a 10mm DIA end mill. We also use the automatic Ramp/Lead options that will calculate Ramp and Lead moves at beginning and end of the profile.

1. Select the “Work Step Data” command in the “Machining” menu to open the “Work Step Data” dialog. Once it is open switch to the “Tool Info” tab.
2. Press the “New” button and input “FN-Outside” as the new Work Step ID and confirm with OK.

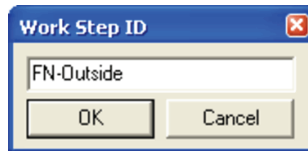

3. Select “Contouring” from the cycle list and the “ODContour” curve from the Path ID list.

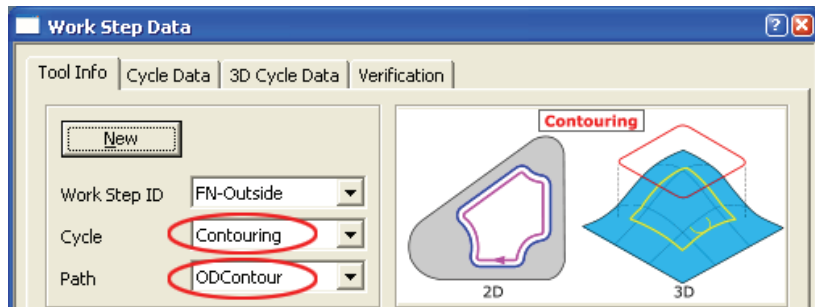

4. Input following tool and technology settings in the appropriate fields located in the “Tool Info” tab.

⇒ Tool Number	: 3
⇒ Diameter (Top)	: 10
⇒ Spindle RPM	: 1500
⇒ Feed (X-Y)	: 300
⇒ Feed (Z)	: 250
⇒ ZDepth	: 15
⇒ Zstep	: 0

5. Select the “Cycle Data” tab and input new cycle specific settings as shown in **Picture 2-47**. This includes the correct “Offset Dir” set to left, “Stock Allow” now “0” and combined Ramp and Lead options.

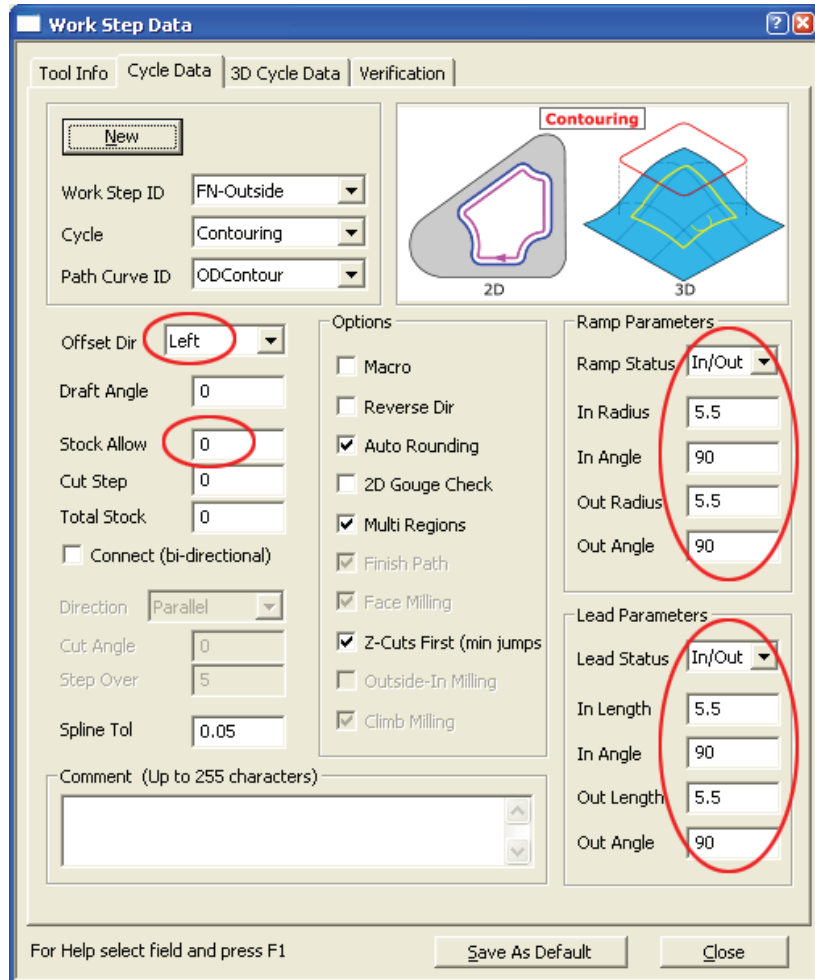

**Picture 2-47**

6. For Verification click the “Verify” button. The system calculates the tool path. Then use the “Simulate Tool” command to get a realistic simulation of the tool movement. See **Picture 2-48**.



Verify



Simulate Tool

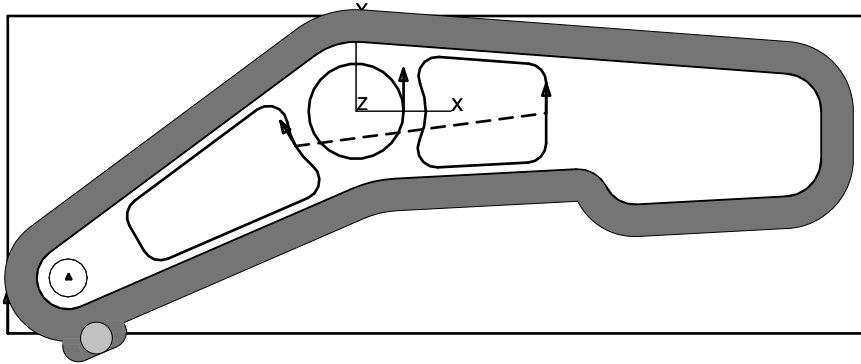

Picture 2-48

The Work Step #4 is now complete. Hit the “Redraw” button  to refresh the screen and remove the verified tool path display.



If the verified tool path is on the wrong side of the profile open the “Work Step Data” dialog. Select the “Cycle Data” tab and make sure that the “Work Step ID” list shows the name of the Work Step you are currently working on. Check that the “Offset Dir” parameter is set to “Left”. If that is already the case, then the path was chained in counter clockwise direction. To change path direction click the “Reverse Dir” checkbox on the same page. Be aware that the “Reverse Dir” option only reverses the calculated tool path without touching the original curve. As an alternative you may select the “Reverse Direction” command located in the “Curves” menu. This command reverses the direction of the current curve.





## CREATING WORK STEP #5 (FINISHING CIRCULAR POCKET)

This Work Step will use the same cycle (“Contour”), tool and machining parameters as the previous one. Therefore it is a good example to demonstrate how to copy a complete Work Step by using the integrated spreadsheet. Once copied, we only have to assign a different path curve.

1. Open the spreadsheet by selecting the “Show Spreadsheet” command from the “Machining” menu. Another way to make the spreadsheet visible or to resize it without selecting a menu command is to use the cursor.

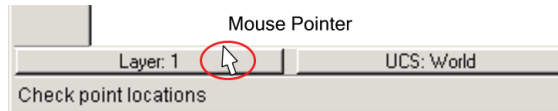
Place your cursor just above the screen prompt.



When the mouse pointer changes to , drag it up to the position you want.

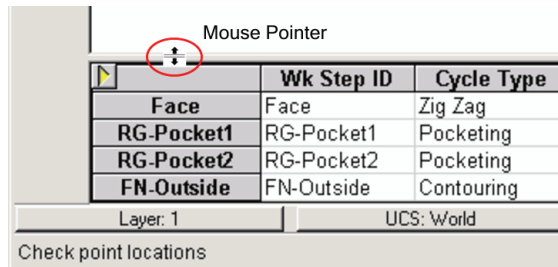

The spreadsheet is like a window shade. Pull it up when you need it and pull it down when you don't.

- To select the complete Work Step to be copied, click the cursor in the first cell as shown in **Picture 2-49**.

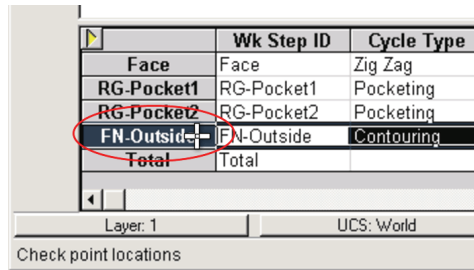

	Wk Step ID	Cycle Type
Face	Face	Zig Zag
RG-Pocket1	RG-Pocket1	Pocketing
RG-Pocket2	RG-Pocket2	Pocketing
FN-Outside	FN-Outside	Contouring
Total	Total	

Layer: 1 UCS: World

Check point locations

Picture 2-49

- The next step is to copy the Work Step to the clipboard. You can activate the spreadsheet menu by selecting the yellow arrow or right-click on the mouse. Either way, once you have activated the menu, select the “Copy Work Step” command. See **Picture 2-50**.

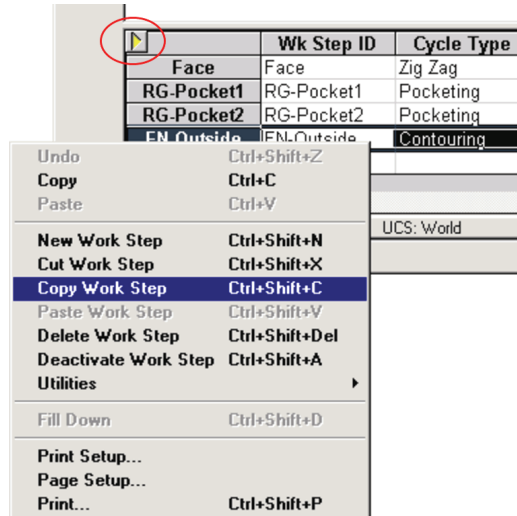

Picture 2-50

4. Now that Work Step “FN-Outside” has been copied to the clipboard, the next step is to select the position where you want the Work Step to be pasted back into the spreadsheet. Remember, the “Paste Work Step” command always inserts the Work Step above the active cell or row in the spreadsheet. As we want the copied Work Step to be inserted at the end, click anywhere within the “Total” row to make this the active row. See **Picture 2-51**.

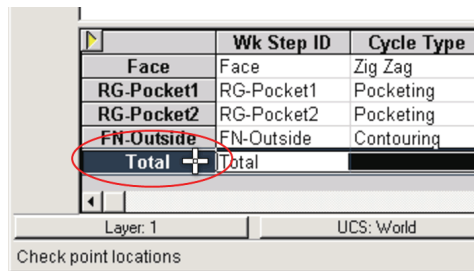

**Picture 2-51**

5. Activate the spreadsheet menu by clicking the yellow arrow or by right-clicking the mouse. Click on the “Paste Work Step” command as shown in **Picture 2-52**. **Picture 2-53** shows the copied Work Step named “2xFN-Outside”, “2x” indicating that it was copied from “FN-Outside”.

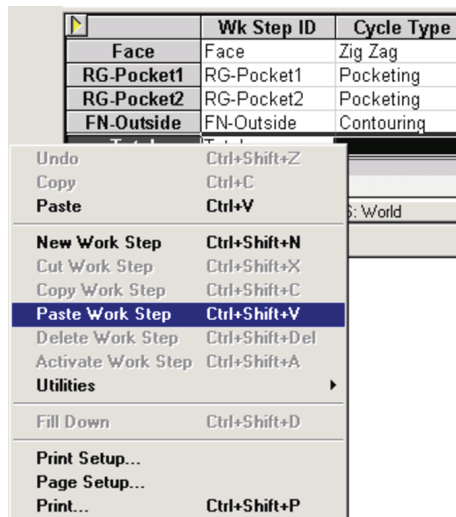

**Picture 2-52**

	Wk Step ID	Cycle Type
Face	Face	Zig Zag
RG-Pocket1	RG-Pocket1	Pocketing
RG-Pocket2	RG-Pocket2	Pocketing
FN-Outside	FN-Outside	Contouring
2xFN-Outside	2xFN-Outside	Contouring
Total	Total	

Layer: 1 UCS: World

Check point locations

Picture 2-53



A similar method is used to reorder Work Steps. The only difference is to use the “Cut Work Step” command instead of “Copy Work Step”. This will remove the Work Step from the spreadsheet and copy the data to the Clipboard. Then select the position where you want the Work Step to be pasted back and select the “Paste Work Step” command.

- As can be seen in **Picture 2-53** the Work Step ID is automatically named “2xFN-Outside”. To rename the Work Step directly select the “Wk Step ID” field with the cursor, type the new name “FN-Pocket1” and press ENTER button. For the result see **Picture 2-54**.

	Wk Step ID	Cycle Type
Face	Face	Zig Zag
RG-Pocket1	RG-Pocket1	Pocketing
RG-Pocket2	RG-Pocket2	Pocketing
FN-Outside	FN-Outside	Contouring
FN-Pocket1	FN-Pocket1	Contouring
Total	Total	

Layer: 1 UCS: World

Check point locations

Picture 2-54

7. As we copied the whole Work Step there is still the “ODContour” curve associated to the new copy. To assign the correct pocket curve use the cursor to select the corresponding field in the “Path ID” column. Select the “Pocket1” curve from the list that opens when pressing the small arrow button. See **Picture 2-55**.

Step ID	Cycle Type	Path ID	TI	Dia	RPM	Cool
	Zig Zag	Boundary	1	14.0	1,200	Mist
set1	Pocketing	Pocket1	1	14.0	1,200	Mist
set2	Pocketing	Pocket2	2	10.0	1,300	Mist
side	Contouring	ODContour	3	10.0	1,500	Mist
set1	Contouring	<b>Pocket1</b>	3	10.0	1,500	Mist

UCS: World      Curve: Drill12      Wk St  
Pick point

**Picture 2-55**

8. For Verification click the “Verify” button. The system calculates the tool path. Use the “Simulate Tool” command to get a realistic simulation of the tool movement. See **Picture 2-56**.



Verify



Simulate Tool

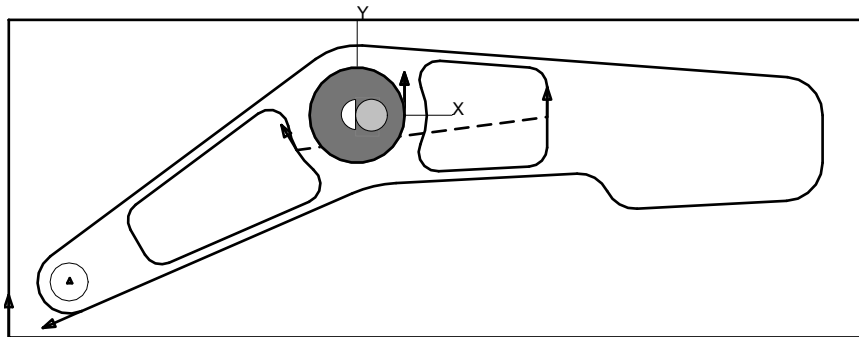

**Picture 2-56**

The Work Step #5 is now complete. Hit the “Redraw” button  to refresh the screen and remove the verified tool path display.

## CREATING WORK STEP #6 (FINISHING INSIDE POCKETS)

This Work Step finishes the two remaining pockets up to the depth of 5mm. Like we did in the previous step we will use the spreadsheet to copy and paste “FN-Pocket1” Work Step to save time, as most of the tool parameters and settings for the new Work Step will be identical. For a more detailed explanation on how to copy and paste Work Step’s in the spreadsheet see the previous Topic (Work Step #5).

1. Open the spreadsheet by selecting the “Show Spreadsheet” command from the “Machining” menu or use the cursor.
2. Select “FN-Pocket1” as the Work Step to be copied. Right-click to open the menu and click the “Copy Work Step” command.
3. Click somewhere in the “Total” line because the “Paste Work Step” command always pastes the Work Step above the active cell or row in the spreadsheet. Right-click to open the menu and click the “Paste Work Step” command. **Picture 2-57** shows the copied Work Step named “2xFN-Pocket1”.

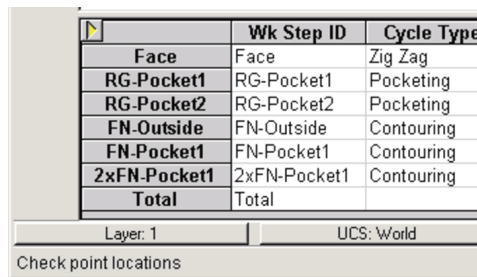

	Wk Step ID	Cycle Type
Face	Face	Zig Zag
RG-Pocket1	RG-Pocket1	Pocketing
RG-Pocket2	RG-Pocket2	Pocketing
FN-Outside	FN-Outside	Contouring
FN-Pocket1	FN-Pocket1	Contouring
2xFN-Pocket1	2xFN-Pocket1	Contouring
Total	Total	

Layer: 1      UCS: World

Check point locations

**Picture 2-57**

4. As in the previous Work Step we will also rename the ID of the copied Work Step. Therefore select the “Wk Step ID” field with the cursor and type the new name “FN-Pocket2” and press ENTER button.

5. To change the depth setting of the new Work Step select the appropriate cell in the “ZDepth” column with the mouse and input “5” as the new depth. See **Picture 2-58**.

	Fd Z	Fd XY	ZSurf	ZDepth	ZStep	Rapid
	75.0	150.0	0.0	15.0	5.0	20.0
	50.0	150.0	0.0	15.0	5.0	20.0
	50.0	150.0	0.0	5.0	0.0	20.0
	250.0	300.0	0.0	15.0	0.0	20.0
	250.0	300.0	0.0	15.0	0.0	20.0
	250.0	300.0	0.0	5.0	0.0	20.0

UCS: FN-Pocket2 ... Path: Pocket1

**Picture 2-58**

6. To change the already assigned path curve use the cursor to select the corresponding field in the “Path ID” column. Select the “Pocket2” curve from the list that opens when pressing the small arrow button. See **Picture 2-59**.

Step ID	Cycle Type	Path ID	TI	Dia	RPM
	Zig Zag	Boundary	1	14.0	1,200 f
Pocket1	Pocketing	Pocket1	1	14.0	1,200 f
Pocket2	Pocketing	Pocket2	2	10.0	1,300 f
Outside	Contouring	ODContour	3	10.0	1,500 f
Pocket1	Contouring	Pocket1	3	10.0	1,500 f
Pocket2	Contouring	Pocket2	3	10.0	1,500 f

UCS: World Curve: Drill12

Pick point

**Picture 2-59**

8. For Verification click the “Verify” button. The system calculates the tool path. Use the “Simulate Tool” command to get a more realistic simulation of the tool movement as shown in **Picture 2-61**.



Verify



Simulate Tool

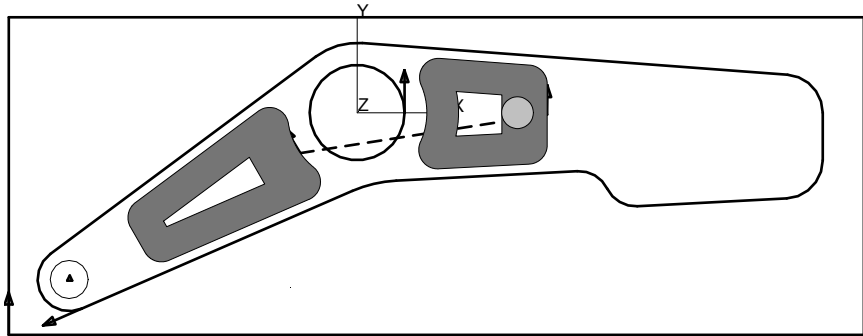

**Picture 2-61**

The Work Step #6 is now complete. Hit the “Redraw” button  to refresh the screen and remove the verified tool path display.



## CREATING WORK STEP #7 (SPOT-DRILLING 12MM HOLE)

After completion of the milling operations we continue with spot-drilling the 12mm DIA hole using the standard “Drilling” cycle

1. Select the “Work Step Data” command in the “Machining” menu to open the “Work Step Data” dialog. Once it is open switch to the “Tool Info” tab.
2. Press the “New” button and input “Spot-Dia12” as the new Work Step ID and confirm with OK.

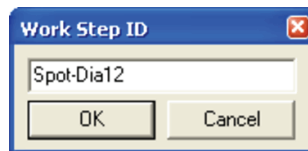

3. Select “Drill” from the cycle list and the “Drill12” curve from the Path ID list.

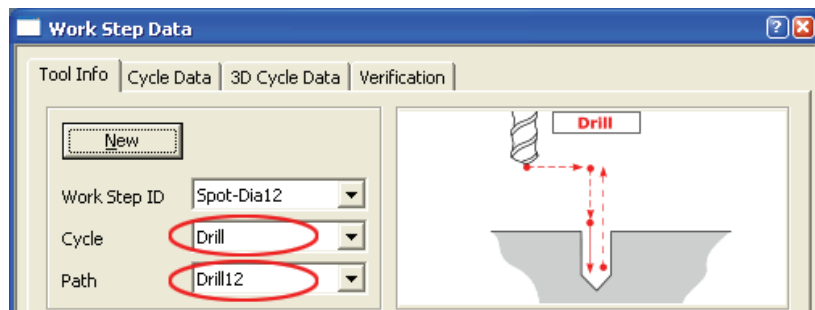

4. Input following tool and technology settings in the appropriate fields located in the “Tool Info” tab.

⇒ Tool Number	: 4
⇒ Diameter (Top)	: 10
⇒ Spindle RPM	: 1600
⇒ Feed (Z)	: 120
⇒ ZDepth	: 3

- To calculate the tool path click the “Verify” button. Then use the “Simulate Tool” command to get a more realistic simulation of the tool movement as shown in **Picture 2-62**.



Verify



Simulate Tool

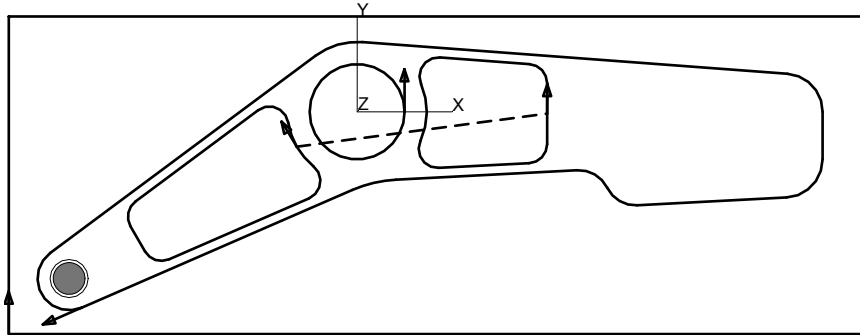

Picture 2-62

The Work Step #7 is now complete. Hit the “Redraw” button  to refresh the screen and remove the verified tool path display.

## CREATING WORK STEP #8 (DRILLING 12MM HOLE)

This Work Step finishes the part by drilling the 12mm DIA hole. We will copy and paste the existing “Spot-Dia12” Work Step and edit cycle, tool and machining parameters using the spreadsheet. There is no need to assign a different path curve since it is the same as the one that was already copied from the “Spot-Dia12” Work Step.

1. Open the spreadsheet by selecting the “Show Spreadsheet” command from the “Work Step” menu or use the cursor.
2. Select “Spot-Dia12” as the Work Step to be copied. Right-click to open the menu and click the “Copy Work Step” command.
3. Click somewhere in the “Total” line because the “Paste Work Step” command always pastes the Work Step above the active cell or row in the spreadsheet. Right-click to open the menu and click the “Paste Work Step” command. **Picture 2-63** shows the copied Work Step named “2xHoles1”.

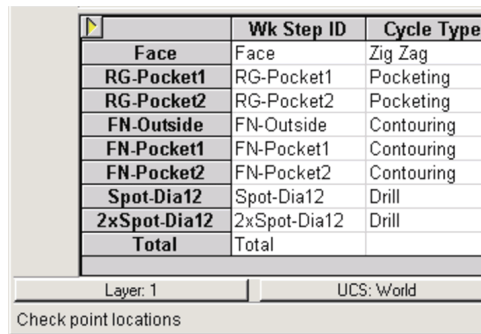

	Wk Step ID	Cycle Type
Face	Face	Zig Zag
RG-Pocket1	RG-Pocket1	Pocketing
RG-Pocket2	RG-Pocket2	Pocketing
FN-Outside	FN-Outside	Contouring
FN-Pocket1	FN-Pocket1	Contouring
FN-Pocket2	FN-Pocket2	Contouring
Spot-Dia12	Spot-Dia12	Drill
2xSpot-Dia12	2xSpot-Dia12	Drill
Total	Total	

Layer: 1      UCS: World

Check point locations

**Picture 2-63**



4. As in the previous Work Step we will also rename the ID of the copied Work Step. Therefore select the “Wk Step ID” field with the cursor and type the new name “Drill-Dia12” and press ENTER button. Move the cursor to the Cycle Type” field and select the “Chip Break” cycle. See **Picture 2-64**.

	Wk Step ID	Cycle Type	Pz
Face	Face	Zig Zag	Bou
RG-Pocket1	RG-Pocket1	Pocketing	Pocl
RG-Pocket2	RG-Pocket2	Pocketing	Pocl
FN-Outside	FN-Outside	Contouring	ODC
FN-Pocket1	FN-Pocket1	Contouring	Pocl
FN-Pocket2	FN-Pocket2	Contouring	Pocl
Spot-Dia12	Spot-Dia12	Drill	Drill
Drill-Dia12	Drill-Dia12	Chip Break	Drill
Total	Total		

Layer: 1 UCS: World

Check point locations

Picture 2-64

5. Use the   arrow keys to navigate through the cells of the “Drill-Dia12” Work Step and assign the settings listed below. The result should appear as in **Picture 2-65**.

- ⇒ Tool Number : 5
- ⇒ Diameter (“Dia”) : 12
- ⇒ Spindle Speed (RPM) : 1200
- ⇒ Feed Rate (“Fd Z”) : 80
- ⇒ Depth (“ZDepth”) : 21
- ⇒ Step (“ZStep”) : 3

	Wk Step ID	Cycle Type	Path ID	TI	Dia	RPM	Coolant	Fd Z	Fd XY	ZSurf	ZDepth	ZStep
Face	Face	Zig Zag	Boundary	1	14.0	1,200	Mist	75.0	150.0	0.0	15.0	5.0
RG-Pocket1	RG-Pocket1	Pocketing	Pocket1	1	14.0	1,200	Mist	50.0	150.0	0.0	15.0	5.0
RG-Pocket2	RG-Pocket2	Pocketing	Pocket2	2	10.0	1,300	Mist	50.0	150.0	0.0	5.0	0.0
FN-Outside	FN-Outside	Contouring	ODContour	3	10.0	1,500	Mist	250.0	300.0	0.0	15.0	0.0
FN-Pocket1	FN-Pocket1	Contouring	Pocket1	3	10.0	1,500	Mist	250.0	300.0	0.0	15.0	0.0
FN-Pocket2	FN-Pocket2	Contouring	Pocket2	3	10.0	1,500	Mist	250.0	300.0	0.0	5.0	0.0
Spot-Dia12	Spot-Dia12	Drill	Drill12	4	10.0	1,600	Mist	120.0	300.0	0.0	3.0	0.0
Drill-Dia12	Drill-Dia12	Chip Break	Drill12	5	12.0	1,200	Mist	120.0	300.0	0.0	21.0	3.0
Total	Total											

Layer: 1 UCS: World Curve: Drill12 Wk Step: Drill-Dia12 Path: Drill12

Check point locations Pick point

Picture 2-65

6. To calculate the tool path click the “Verify” button. Then use the “Simulate Tool” command to get a more realistic simulation of the tool movement as shown in **Picture 2-66**.



Verify



Simulate Tool

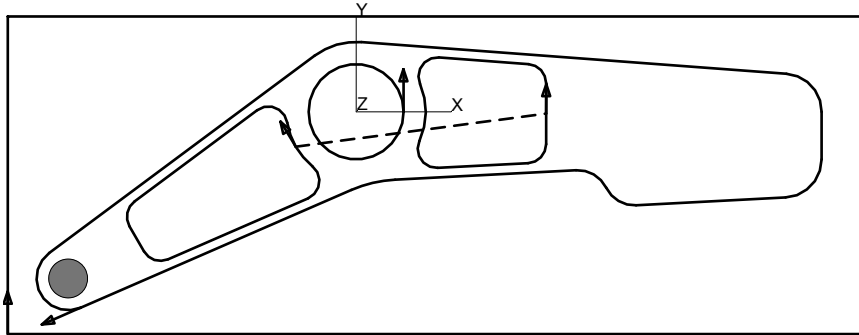

**Picture 2-66**

The Work Step #8 is now complete. Hit the “Redraw” button  to refresh the screen and remove the verified tool path display.

## ESTIMATING TOTAL MACHINING TIME

The “Verify All” command in the “Post” menu is used to estimate the total machining time. It performs an on-screen verification of all Work Steps in memory, in the machining order. The total machining time (not including rapid traverse or tool change time) is displayed in a dialog box at the end of the verification process. To close the dialog click OK. To get the same view as shown in **Picture 2-67**, switch to isometric using the “View Isometric” command and select “Verify All” to start tool path calculation.



View Iso-  
metric



Verify All

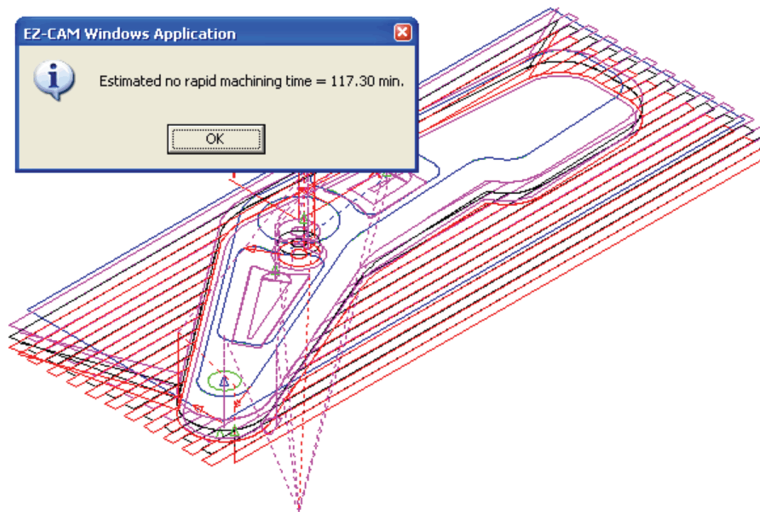

**Picture 2-67**



It is very important for the “3D Preview” simulation in the next section to have toolpaths of all work steps verified completely. If you previously interrupted any computation during “Verify” by hitting “Escape”, or have started a new session and loaded your previously saved work, you must first “Verify All” work steps.

### 3D SOLID PREVIEW

One of the most powerful EZ-CAM features is the 3D solid preview function. This function shows an animated tool cutting a solid model of the programmed part. Once the simulation is finished or interrupted by the user pressing “Esc” key, all dynamic view commands to rotate, zoom or move the simulated model on the screen are available. If no “Stock Setup” has been defined when the “Preview 3D” command is called, the system automatically calculates the “Stock” size, according to the maximum calculated tool movements. For the tutorial we will manually assign the stock size using the “Stock Setup” dialog that can be opened from the “Machining” menu.

1. Select the “Stock Setup” command from the “Machining” menu and input the values as shown in **Picture 2-68**. Close the dialog with OK.

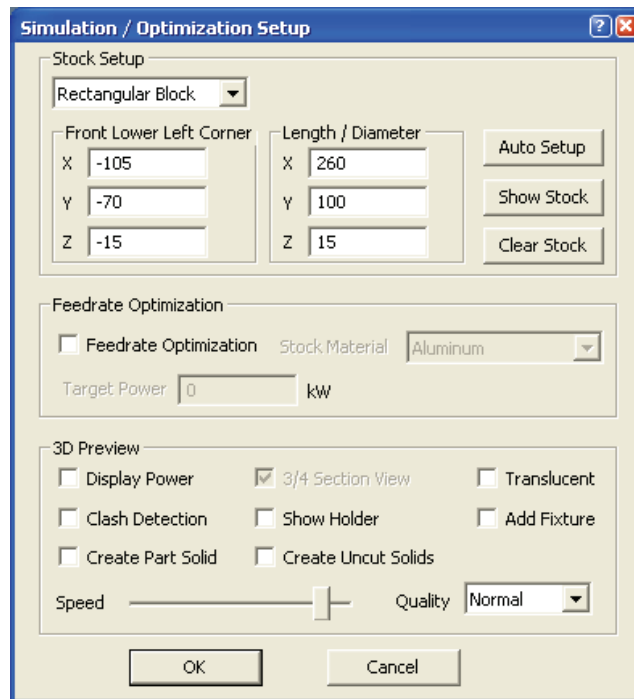

**Picture 2-68**

2. Before starting the preview select the “Isometric View” command. Then start the simulation using “Preview 3D” command from the “Machining” menu or the corresponding button. See **Picture 2-69**.



View Iso-  
metric



Preview 3D

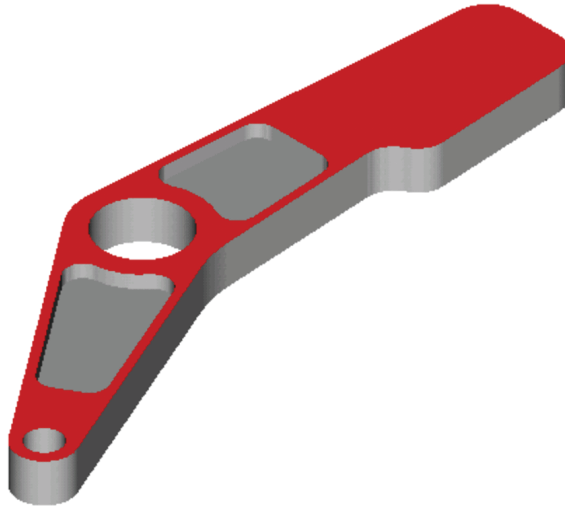

**Picture 2-69**

3. Once the simulation stopped you can change the on-screen view by using the dynamic view commands (Rotate, Pan, Zoom) from the “View / Dynamic Viewing” menu.



Dynamic Rotate



Dynamic Zoom



Dynamic Pan



## SAVING THE PART

It is very important to save the newly created or edited part from memory to disk periodically during a session as well as at the end to ensure that no information is lost. The EZ-CAM “Save” and “Save as” commands under the File menu transfer files from system memory to a hard disk or other media. In EZ-MILL, the part information is stored in two different types of files, the “Part” file using the extension "3DP" and the associated “Geometry” file with extension "GEO". This flexibility allows the user to load an existing part file to be used with newly created geometry and path curves.

File Type : **GEOMETRY**  
Extension : **GEO**  
Data : Geometry Elements (lines, arcs, etc.), Curves,  
User Coordinate Systems (UCS)

File Type : **PART Files**  
Extension : **3DP**  
Data : Work Step Data (Technology & Machining Information)

There is no specific rule what should be saved first. Of course, if there is only one kind of data in memory (Work Steps or Geometry) the “Save as” dialog will automatically be set to the correct file type.

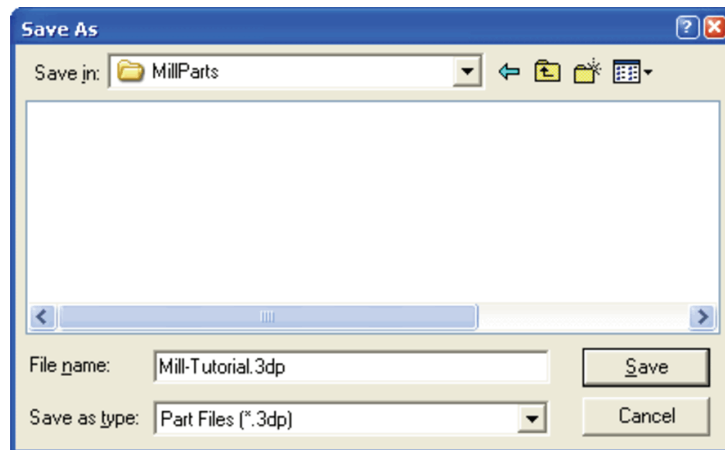

Picture 2-70

1. Select “Save as” command from the “File” menu.
2. Select the appropriate drive and folder where the geometry and part files should be stored. You can use the “EZCAMW \ MILLPARTS” folder that was automatically created by the setup routine.
3. Select “Geometry (\*.GEO)” from the “Save as type” list box to store the geometry data.
4. Type the new filename “Mill-Tutorial” in the File Name box and click the “Save” button. The file extension is added automatically.
5. To store the machining information (Work Step Data) select “Part Files (\*.3DP)” from the “Save as type” list box and click “Save” again.



If you have already saved the geometry, the software automatically inserts a part file with the same name but different extension (\*.3DP) in the “Save” menu when the first Work Step is created. All you have to do is to select “Save All” option from the “File” menu or the corresponding toolbar button.



Save  
All

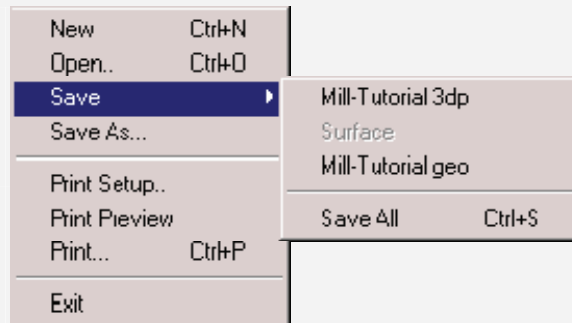

The software will save and overwrite the existing files without any screen prompt. You can use this command anytime for fast saving of your work.



It is not possible to save data when the software is running in evaluation mode. The “Save”, “Save as” and “Print” commands are disabled.

## CREATING CNC CODE

Now that the part program has been created, it must be converted to run on a NC control by running the “Post” command with the appropriate “Post-Processor” for your machine.



The CNC data file or “Post-Processor” is used as a "template" to format the part program data file that was created in EZ-Mill. This template consists of program formats (e.g., TOOL CHANGE, LINEAR MOVE, RAPID MOVE, etc.) that determine the structure of a part program for a specific CNC. To create or edit a “Post-Processor” a special editor called “MBuild” is required.

1. Select “Post” command in the “Machining” menu to open the “Post Process” dialog.

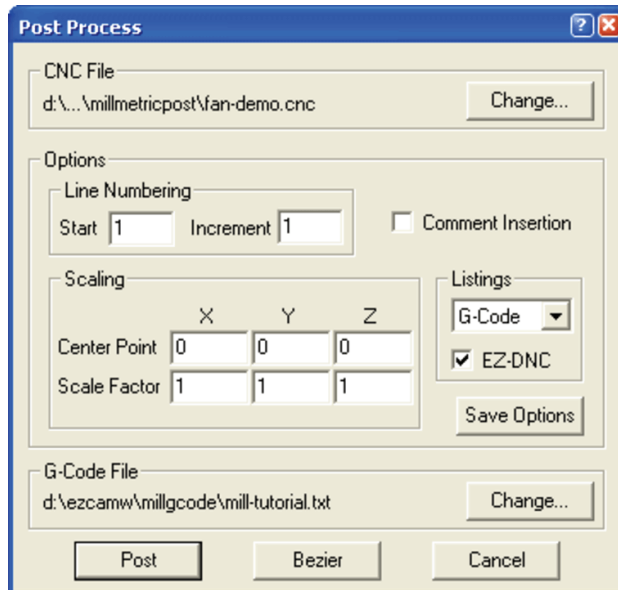

Picture 2-71

2. First you need to select the postprocessor. If the one desired is already loaded and displayed in the section “CNC-File”, continue to the next step. Otherwise use the “Change” button to browse your system for a different one. For this tutorial you may use the “FAN-DEMO.CNC” post (standard metric post that creates Fanuc style code).



Standard postprocessor folders created by the EZ-CAM v15 setup:

INCH

<DRIVE>: \ EZCAMW \ EZCAM15 \ MILLINCHPOST

METRIC

<DRIVE>: \ EZCAMW \ EZCAM15 \ MILLMETRICPOST

3. Select the “G-Code” option from the “Listings” list box. The computed program text will be displayed on the screen.
4. Activate (check) the “EZ-DNC” option. This will automatically start the “EZ-DNC” application when posting of the part file is finished and load the newly created file for sending it to the machine using the serial port. See Chapter 6 “Communication with the Control” for more information about EZ-DNC.
5. Next is the “G-Code File” section. Here the default name and directory for the computed program file is displayed. The name is taken from the part file that was saved before. The default directory is “EZCAMWMILLGCODE”.



Ensure that part file and postprocessor share the same dimension unit (“Metric” for this tutorial). The system will generate a “Dimension Unit Conflict” message, but then automatically scale the NC-Code according to the dimension specified in the postprocessor.

See online help for more information about the “Setup” dialog located in the “View” menu.

6. Click the “Post” to start posting. The Processing window will be displayed showing messages followed by listings of ASCII code created. When all Work Steps have been processed, a final message dialog box is shown. See **Picture 2-72**.



Picture 2-72

7. Click OK to close the message dialog box. To close the Processing window click  at the top right-hand corner of the window.

**Congratulations!**

**You've completed the EZ-MILL 2D Tutorial !**





# CHAPTER 3.

## EZ-MILL PRO / 3D TUTORIAL

### OVERVIEW

This tutorial is intended to present to you the 3D Machining Wizard, which makes 3D part programming easier than the regular Work Step Data window. The 3D Machining Wizard collects information about the most important machining parameters from the user, in a brief window, avoiding confusing settings. Some parameters are pre-defined to the most appropriate values for the current machining method; however, the user always has the option to alter them as to his needs.

The solid model can be imported into EZ-MILL Pro in several file formats, like sldprt, igs, step, sat, x\_t or x\_b. Beginning from version 19, SolidWorks users can transfer the 3D model directly from the SolidWorks working window to EZ-CAM in one click. The 3D Machining Wizard automatically detects and assigns all the surfaces to the recently created Work Step; however, the user can choose to deselect any of them.

Throughout the tutorial you will find important notes , tips  or references to the online help where additional information on the commands and functions is provided.

### CAVITY MACHINING

In this tutorial we will machine a detergent bottle mold. It is a cavity of a bottle divided from the centerline. It has a boss corresponding to the handle portion, which creates an island in the middle of the cavity. The mold cavity has both steep and flat sections which we need to consider at the finishing stage. Surface transitions have fillets in several dimensions.

The first operation will be roughing with a large tool to get rid of the bulk material inside the cavity. Secondly we will apply a re-roughing workstep to machine the uncut material with a relatively small tool. The finishing operation will be carried out by a 3D Equidistant machining method providing even surface roughness throughout the mold. Finally we will introduce a re-finishing technique and cut the remaining material left by the relatively larger tool of the previous finishing operation.

## BASIC PROGRAMMING STEPS

Before we continue with the tutorial let us explain the basic steps needed to create the part program.

- STEP 1. Load (Import) the 3D Solid Model of the Part to be machined**  
For our sample part we will use a 3D model created in Rhino and saved in ACIS format “sat”. Other common CAD translation formats can also be used to import external data to EZ-Mill Pro, such as igs, 3dm, step, x\_t, x\_b, etc. SolidWorks users can directly transfer the solid model to the EZ-CAM window using the “Update Solidworks Model” command.
- STEP 2. Define World/UCS origin on the 3D Solid Model**  
We will change the World/UCS origin point to a reference location on the real part stock.
- STEP 3. Create Work Steps and set all Machining Parameters**  
We will create machining work steps, specify tool and operation parameters, create path Curves (if required), and verify the toolpaths. Also we will create rough and re-rough surface milling operations, leaving stock on all surfaces then finish and re-finish surface milling operations; removing the remaining material, leaving minimal cusps.
- STEP 4. Check Material Removal and Surface Finish**  
We will check to make sure all material is removed and the surface finish smoothness is acceptable.



The EZ-MILL Pro 3D Machining Wizard Tutorial is set up in Inch with all Inputs and Dimensions in Inch !



## THE PART

Below is the image of the sample part we will machine in this tutorial. It is a detergent bottle mold with an approximate size of 13.5"x11.5". The cavity of the mold has steep walls near the top surface, and a boss with steep walls corresponding to the handle of the bottle. There are fillets with radii changing between .079" and .2" in surface transition sections.

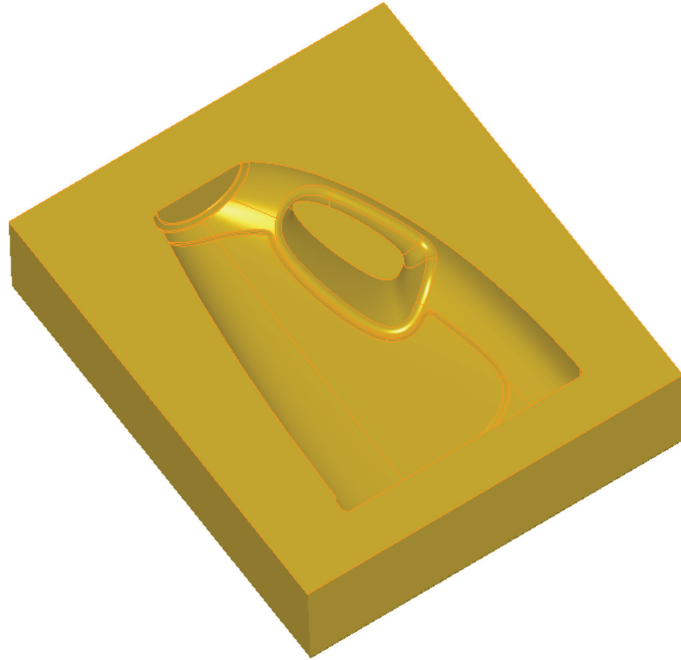

**Picture 3-1**

## SETTING THE PREFERENCES

Let's first set some important parameters such as units and other viewing preferences to ensure the compatibility of your system with the tutorial.

1. Select the "New" command from the "File" menu to restart EZ-Mill Pro and to clear the memory before continuing with the tutorial. Make sure the "EZ-Mill Pro" level is active and press OK to start over.

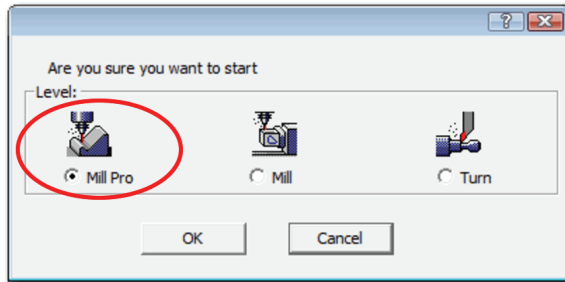

The "New" dialog is also used to switch between the EZ-Mill and EZ-Turn modules. Before the dialog opens the system checks the software protection key for activated modules. Modules or levels that are not activated will be marked by appended "DEMO" text. When working in "Demo" (evaluation) mode, it is not possible to print or save data. The corresponding "Save", "Save as" and "Print" commands are disabled.

When closing the EZCAM application, the system automatically stores the last used level as default for the next session.

2. Select the "Setup" command from the "View" menu
3. Select the "Inch" option button as the input dimension system.
4. Click the "Background" list box and select "White".
5. Click the "Show Toolpath" list box and select "Blank Verify". This will cause verified tool paths to be blanked when the screen is redrawn.

6. Click the "Show Direction" list box and select "None". This will hide the small arrows indicating the surface normals and curve directions. It can later be activated at any time.
7. Check "Save as Default". The system will store all dialog settings as defaults for future sessions.
8. After the preferences have been correctly set, click OK.

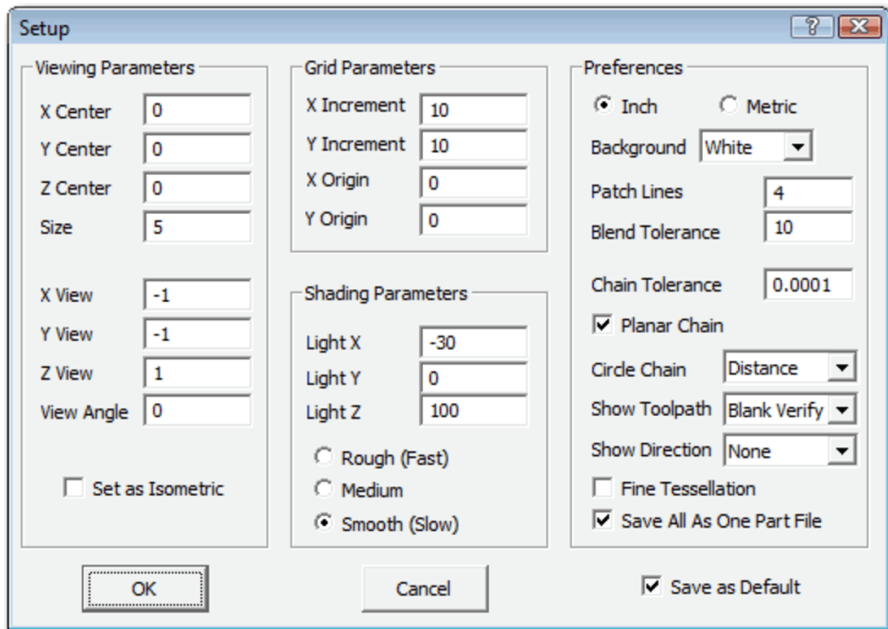

**Picture 3-2**

The initial setup for the EZ-MILL Pro 3D Machining Wizard Tutorial is now complete. Continue with the next section to create the geometry necessary for this part.

## LOADING THE SOLID PART

We will begin the exercise by loading the surface geometry that represents our part. There are several methods to accomplish this process. The first method is to import a solid/surface type of model into EZ-CAM in one of the common CAD file formats, such as iges, sat, step, sldprt, sldasm, x\_t, x\_b, dwg, vda or 3dm. Secondly, you can open the model in our companion CAD product, Rhino, then copy/paste to EZ-Mill using the special command “Paste from Rhino” found under the “Edit” menu. The last method is for SolidWorks users; they can load the model into SolidWorks and transfer the file to EZ-CAM by using the new “Update Solidworks Model” command. In this tutorial we choose the first method and load a SAT file representing the 3D model.



You may refer to “[EZ-Mill 3D Machining Solids Tutorial](#)” to get information about “Copy and Pasting the Model from Rhino”

The “SAT” file containing the 3D model has already been copied into the “EZ-CAM\MILLPARTS” folder by the EZ-CAM setup. Follow the steps below to load the data.

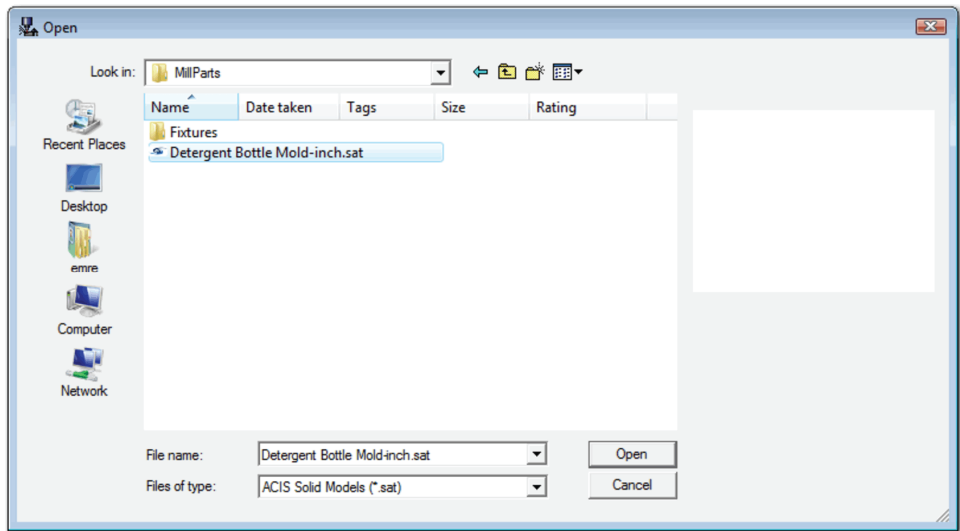

**Picture 3-3**

1. Select the “Open” command from the “File” menu to open the file dialog. In **Picture 3-3** you can see the dialog displayed on a Windows Vista workstation system. This

dialog may vary according to the version of the Windows™ operating system running on your machine.

2. Select the folder “EZCAMW \ MILLPARTS” on the drive where you installed the software
3. In the “Files of Type” list select “ACIS Solid Models (\*.sat)”.
4. Select the file “Detergent Bottle Mold-inch.sat” and click the “Open” button. The imported surface geometry should then appear as shown in **Picture 3-4**.

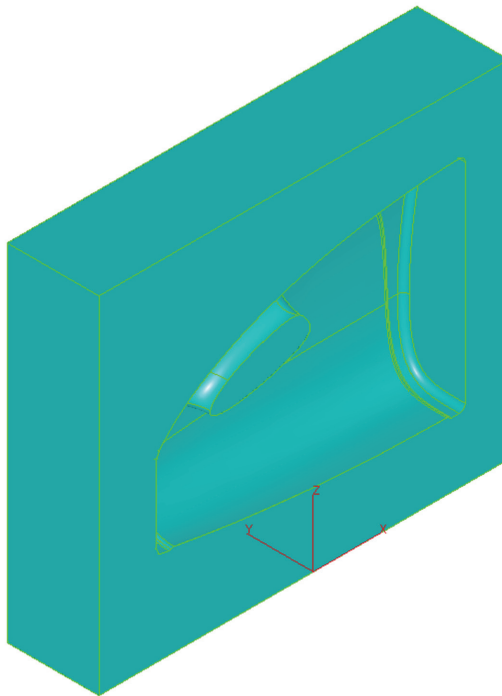

**Picture 3-4**

## DEFINING WORLD/UCS ORIGIN OF THE PART

We will define the part origin point as the zero position that will be assigned to the stock before machining on the CNC machine. In this tutorial the front left corner of the part block will be selected as the origin point--using the default coordinate system "World". The top plane of the part will be designated as Z=0 position.

1. To define the new "World" origin point, select the "World/UCS, Three Points" command from the "View" menu or click the corresponding button.



World/UCS, Three Points

2. Select the "Snap All" command from the "Edit > Point Picking" menu or click the corresponding button.



Snap All

3. Click the corner points 1, 2 and 3 on the part; See **Picture 3-5**. These points designate new origin point, X-axis direction and Y-axis direction respectively.

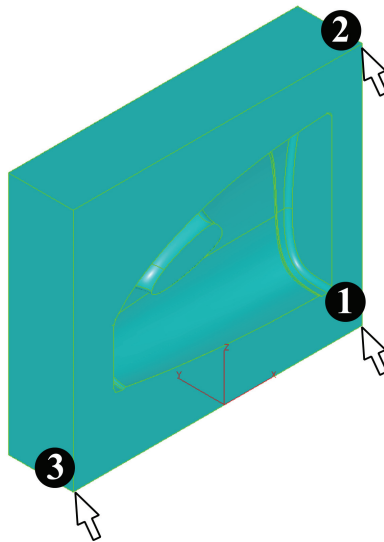

Picture 3-5

4. The part will be oriented as to the new position of “World” coordinate system that is appropriate for machining as shown in **Picture 3-6**.

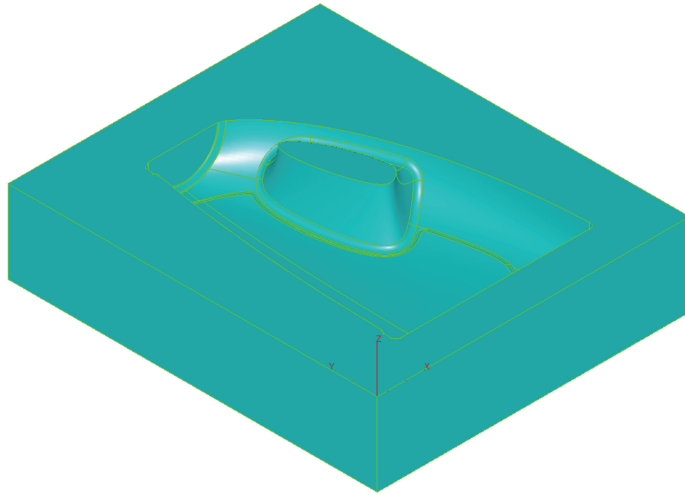

**Picture 3-6**

## CREATING THE PART PROGRAM

Now that we have completed setting the origin point of the part we are ready to begin defining the work steps to machine it. Each work step uses a specific method (Roughing, Finishing, etc.) and a Toolpath Type (Pocketing, Parallel, etc.) along with its associated tool settings and parameters to create a toolpath that machines the assigned curves and surfaces. Our part program will consist of the following work steps.

Work Step ID	Purpose
Roughing	Rough the cavity leaving a stock allowance of .005" with a .625" flat tool. We will use a Pocketing toolpath pattern generated within the boundaries of each surface slice computed using a Z-step value of .04".
Re-Roughing	Machine the uncut material sections where the previous tool of the Roughing operation could not fit. The system will automatically detect each uncut boundary and create an auxiliary curve. A pocketing type of toolpath will be used with a relatively smaller flat tool with a diameter of .1875".
Finishing	Finish the cavity surfaces, limited by the curves defining the outer and inner boundaries. The 3D Equidistant type of toolpath will generate evenly distributed toolpath passes all around the finished surfaces. A ball nose tool with a diameter of .375" will be used.
Re-Finishing	Re-Finish the rest material remaining from the Finishing operation, using a relatively smaller ball nose tool with a diameter of .125". The system will automatically detect the sections that have smaller indentation and concavity than the Finishing tool can cut and generate a 3D toolpath around them.



## CREATING WORK STEP “1\_ROUGHING”

The first work step will machine the bulk material inside the cavity in order to prepare it for the finishing operation. We will use the “3D Machining Wizard” for defining the machining parameters. The wizard automatically selects all the visible surfaces as “cut surfaces” and sets the “surface” parameter in the Z Data section to the highest Z point of the surfaces. Besides it sets several parameters to the most appropriate values for the active operation. We will not specify any boundary curves for the roughing operation and let the system detect the outer boundary (silhouette) of the cut surfaces.

1. Select the “3D Machining Wizard” command in the “Machining” menu or click the corresponding button.



3D Machining Wizard

2. Input “1\_ROUGHING” as the new Work Step ID. Confirm with OK.

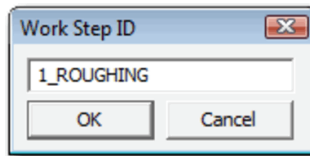

3. Select “ROUGHING” from the Method list box.

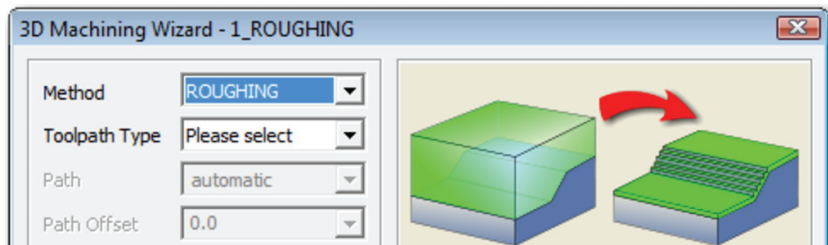

4. Select “Pocketing” from the Toolpath Type list box. Until a toolpath type is selected all other input boxes appear as disabled.

5. On the “**3D Machining Wizard**” window, change the settings according to the table below and ensure that all parameters are set as shown in **Picture 3-7**.

Dialog Field	Value	Comment
Type	Flat	Flat type endmill
Number	1	Tool number in tool magazine
Diameter (Bot.)	0.625	Defines the diameter of the tool
Spindle RPM	750	Sets spindle RPM to 750
Feed (X-Y)	50	Cutting feed rate in XY plane (inches/minute)
Feed (Z)	5	Cutting feed rate for Z depth moves
Surface	0	Set our Z surface to the top of the block. This value is automatically detected by the system as the top point of the solid body.
Rapid	0.5	Rapid positioning plane over “Z Surface” plane during transversal rapid moves
Clear	0.05	Plunge plane over “Z Surface” plane (Rapid to Feedrate)
Step-Z	0.04	Incremental depth per Z-level pass
Fin Allow	0.005	Finishing allowance value. Material that remains along the surfaces to be removed later with the finishing operation
Step Over	50%	The distance between the tool passes on the machining plane. The value is given as the percentage of the tool diameter. (you may opt to use an absolute value instead)

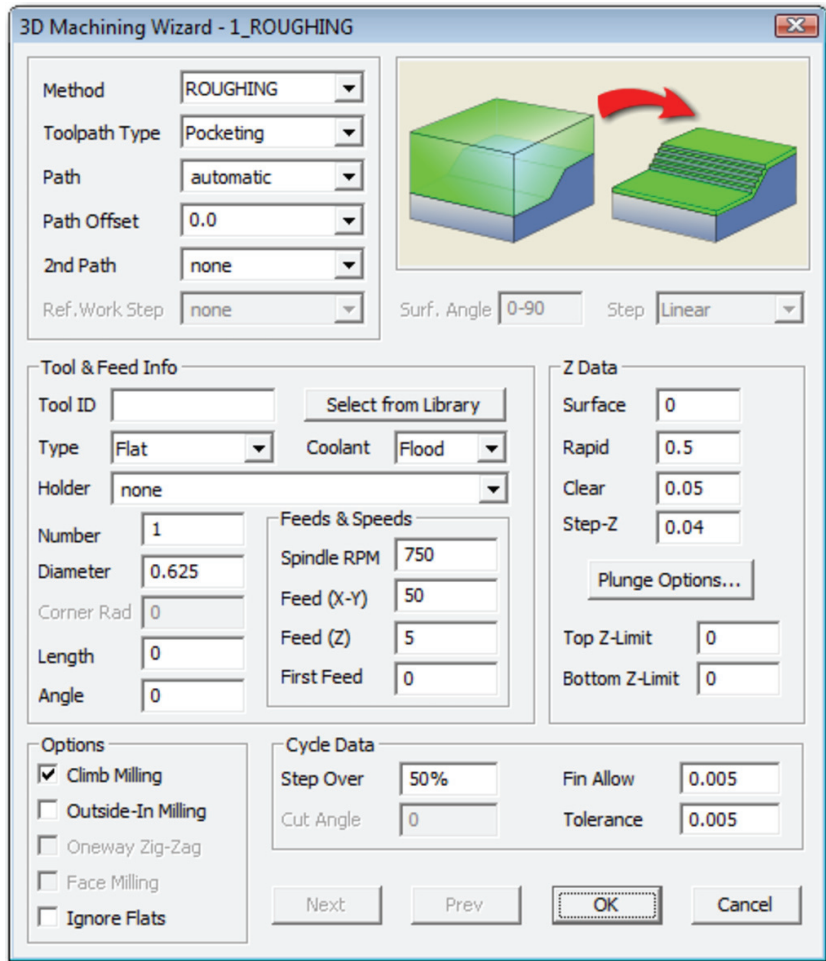

Picture 3-7

- Click the “Verify” button and the system starts calculating the toolpath. See **Picture 3-8**.



Verify

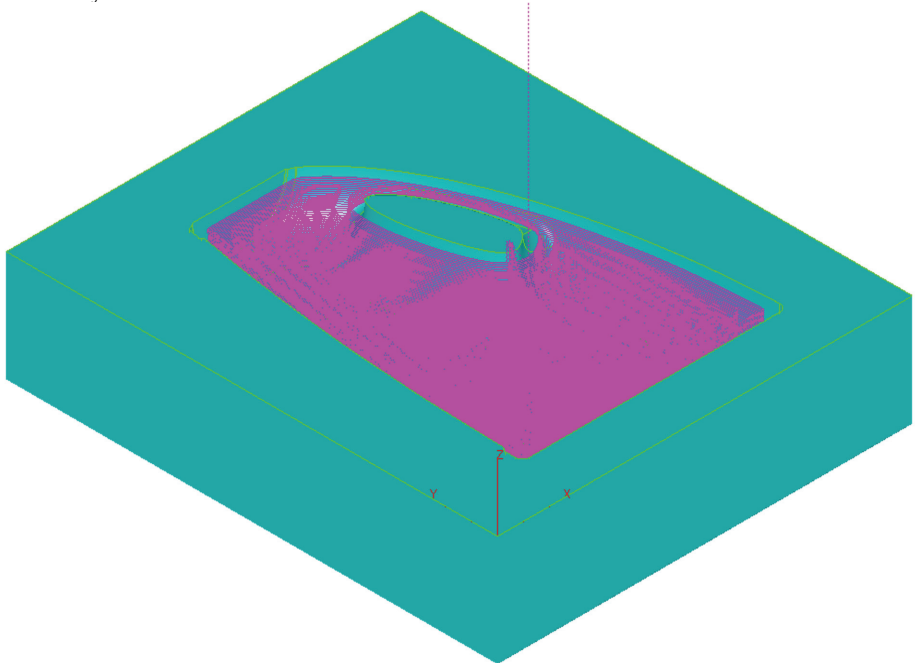

**Picture 3-8**

The Work Step #1 is now complete. Hit the “Redraw” button  to refresh the screen and remove the verified tool path display.

## CREATING WORK STEP “2\_RE-ROUGHING”

The second machining work step will remove material only in the sections where the roughing tool could not fit. We will use a tool with a relatively smaller diameter. EZ-CAM system will detect the uncut boundaries at every roughing slice of the reference Work Step, and create an auxiliary curve that will be machined according to the selected re-roughing toolpath type.

1. Select the “3D Machining Wizard” command in the “Machining” menu or click the corresponding button.



3D Machining Wizard

2. Input “2\_RE-ROUGHING” as the new Work Step ID. Confirm with OK.

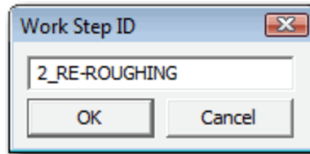

3. Select “RE-ROUGHING” from the Method list box.
4. Select “Pocketing” from the Toolpath Type list box.

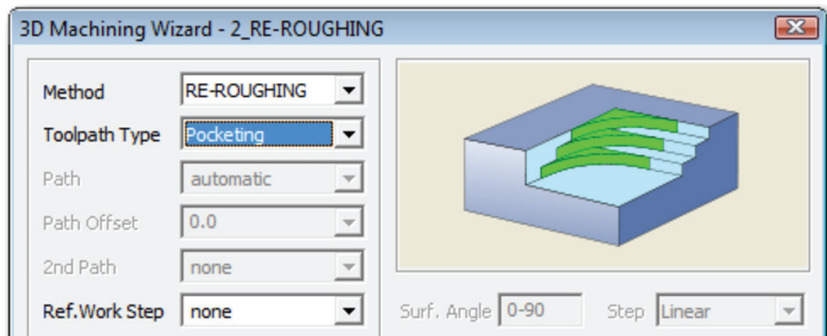

5. Select “1\_RE-ROUGHING” from the Ref. Work Step list box.

6. On the “**3D Machining Wizard**” window, change the settings according to the table below and ensure that all parameters are set as shown in **Picture 3-9**.

Dialog Field	Value	Comment
Type	Flat	Flat type endmill
Number	2	Tool number in tool magazine
Diameter (Bot.)	0.1875	Defines the diameter of the tool
Spindle RPM	2000	Sets spindle RPM to 2000
Feed (X-Y)	15	Cutting feed rate in XY plane (inches/minute)
Feed (Z)	5	Cutting feed rate for Z depth moves
Surface	0	Set our Z surface to the top of the block. This value is automatically detected by the system as the top point of the solid body.
Rapid	0.5	Rapid positioning plane over “Z Surface” plane during transversal rapid moves
Clear	0.05	Plunge plane over “Z Surface” plane (Rapid to Feedrate)
Step-Z	0.04	Incremental depth per Z-level pass is automatically set to the same value as the reference work step, however can be reduced to a lower value in order to decrease the tool load
Step Over	50%	The distance between the tool passes on the machining plane. The value is given as the percentage of the tool diameter. (you may opt to use a decimal value instead)

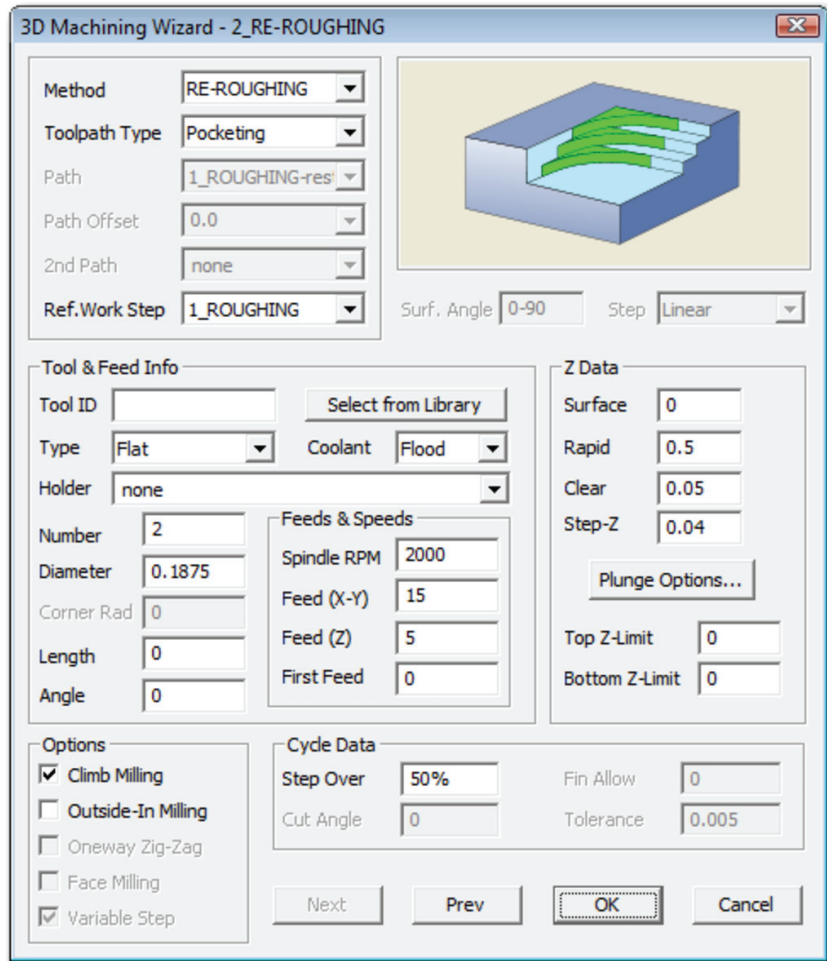

Picture 3-9

- Click the “Verify” button and the system starts calculating the toolpath. See **Picture 3-10**.



Verify

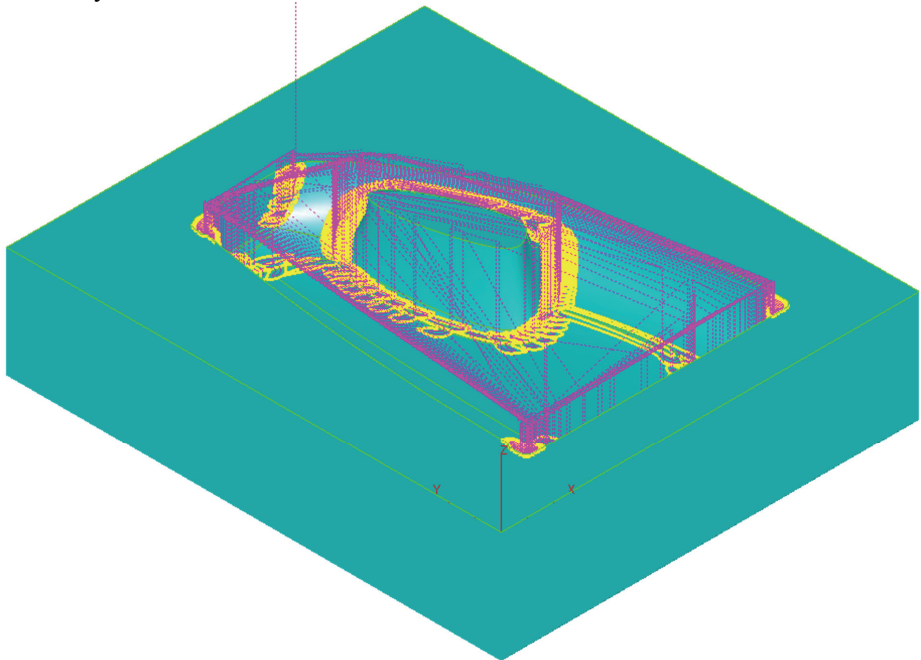

**Picture 3-10**

- An auxiliary curve in yellow representing the machining area around the uncut sections appears after generating the toolpath. In order to hide it, select the “Blank” command from the “Edit” menu or click the corresponding button.



Blank



9. Select the curve “1\_ROUGHING-rest” in the object list box. The yellow uncut boundary curve and the toolpath disappear.

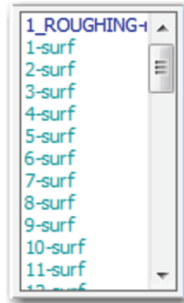

10. Click the “Escape” button in the toolbar or hit “Esc” button on the keyboard to abort Blank command and to prevent accidental selection of an object on the screen.



Escape

## DEFINING THE BOUNDARY CURVES FOR FINISHING OPERATION

We need to create curves to define machining borders for our finishing operation by using the solid model representation of the 3D part. We have few choices for curve creation from the 3D model such as “Face Boundary”, “X-Y Intersection” or “Silhouette Boundary” commands. Here we use Face Boundary command to create the outer boundary of the mold cavity and inner boundary from the flat surface around the handle section.

1. To create the outer finishing boundary curve choose the “Face Boundary” command from the “Curves” menu, type “outer” as the Curve ID and click OK.



Face Boundary

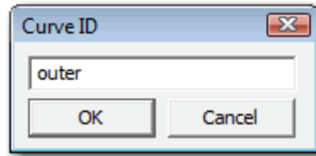

2. Select the “Verify Mode” command in the “Edit” menu or click the corresponding button. This mode displays the selected object in different color and waits for our confirmation allowing us to abort the process or continue selecting multiple objects.



Verify Mode

3. Now we should select the surface on the part from which the face boundary curve will be created. Click anywhere on the outermost top surface. After clicking, the color of the surface changes to inform you that it’s selected. See **Picture 3-11**.

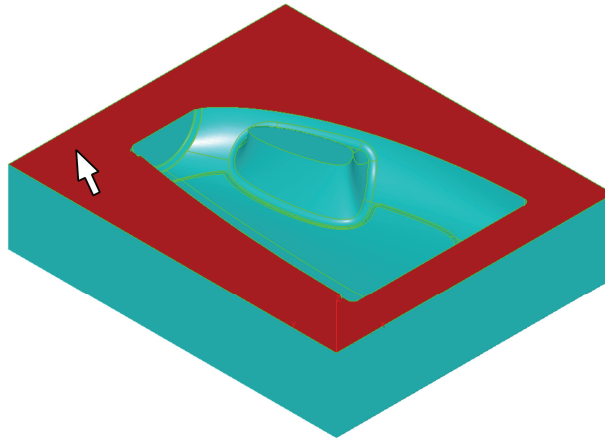

**Picture 3-11**

4. Click the “Enter” button in the toolbar or hit “ENTER” button on the keyboard to confirm. See **Picture 3-12**.



Enter

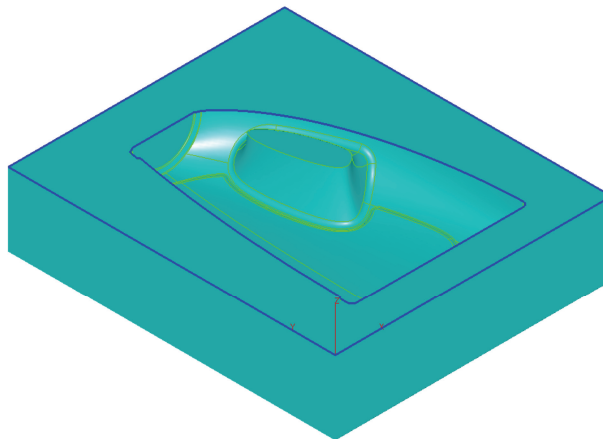

**Picture 3-12**

- We only need the curve created at the intersection of the top plane and the cavity. So it is better to delete the outermost one to prevent confusion. Select the “Delete” command from the “Edit” menu or click the corresponding button. Then select the “Curve...” command from the “Edit > Discrimination” menu or click the corresponding button.



Delete



Discrim. Curves

- Click the blue curve on the outer edge of the part and hit ENTER. See **Picture 3-13**.

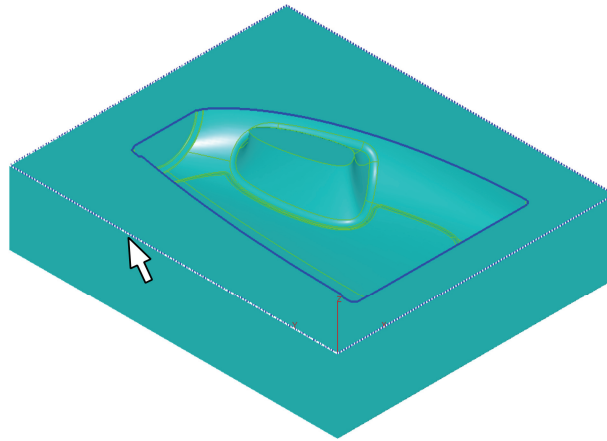
**Picture 3-13**

- For creating the inner finishing boundary curve choose the “Face Boundary” command from the “Curves” menu, type “inner” as the Curve ID and click OK.



Face Boundary

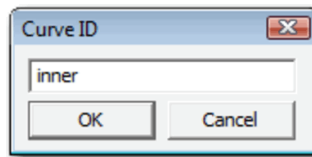

- Click the planar surface on top of the boss in the cavity corresponding to the handle of the bottle. After clicking, the color of the surface changes to inform you that it's selected. See **Picture 3-14**.

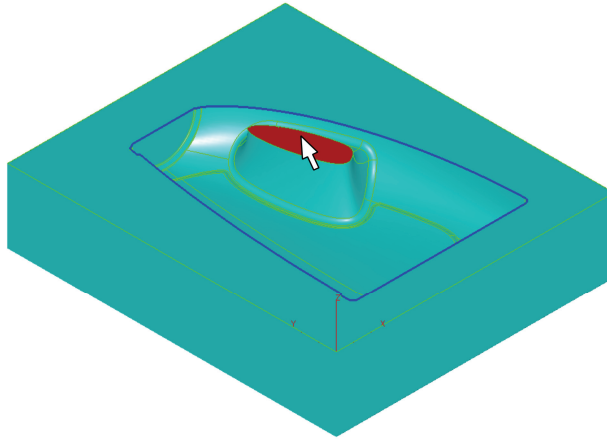

**Picture 3-14**

- Click the “Enter” button in the toolbar or hit “ENTER” button on the keyboard to confirm. You can see the result in **Picture 3-15**.

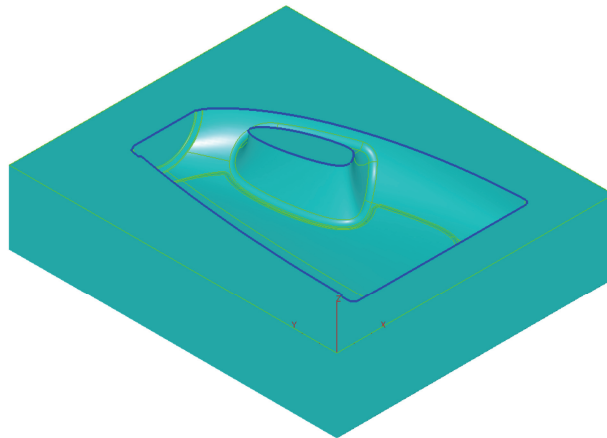

**Picture 3-15**

## CREATING WORK STEP “3\_FINISHING”

In our third work step we will finish the cavity surface using our most efficient finishing technique “3D Equidistant”. This technique ensures an equal 3D distance between adjacent toolpath passes resulting in an even surface roughness all over the part eliminating the need for another finishing operation if the step over value is adequate.

1. Select the “3D Machining Wizard” command in the “Machining” menu or click the corresponding button.



3D Machining Wizard

2. Input “3\_FINISHING” as the new Work Step ID. Confirm with OK.

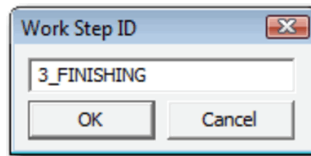

3. Select “FINISHING” from the Method list box.

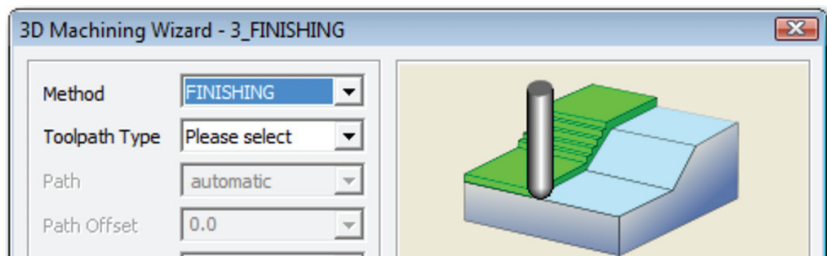

4. Select “3D Equidistant” from the Toolpath Type list box.
5. Select “outer-1” from the Path list box to define outermost machining boundary.
6. Select “inner” from the 2nd Path list box to define the island region that should not be machined by the finishing operation.

7. On the “**3D Machining Wizard**” window, change the settings according to the table below and ensure that all parameters are set as shown in **Picture 3-16**.

Dialog Field	Value	Comment
Type	Ball	Ball type endmill
Number	3	New tool number for finishing operation
Diameter (Bot.)	0.375	Defines the full diameter of the tool
Spindle RPM	1500	Sets spindle RPM to 1500
Feed (X-Y)	30	Cutting feed rate in XY plane (inches/minute)
Feed (Z)	5	Cutting feed rate for Z depth moves
Step	S-Link	This parameter controls the step over moves between toolpath passes. S-Link eliminates any possible corner on the step over move eliminating knocking effect and ensuring smoother operation of the machine
Fin Allow	0	Finishing allowance value is set to 0 to reach the final surface after performing this operation
Step Over	10%	For 3D Equidistant type of toolpath Step Over is the 3D distance between the tool passes. The value is given as the percentage of the tool diameter. Since we want to leave minimal cusps on the surface “Step Over” distance is set as 10% of the tool diameter. However, lower values can be preferred to obtain smoother surface finish.
Outside-In Milling	ON	Click this checkbox to generate the toolpath starting from the outermost loop and collapsing to the center. This ensures toolpath loops arranged from top to bottom

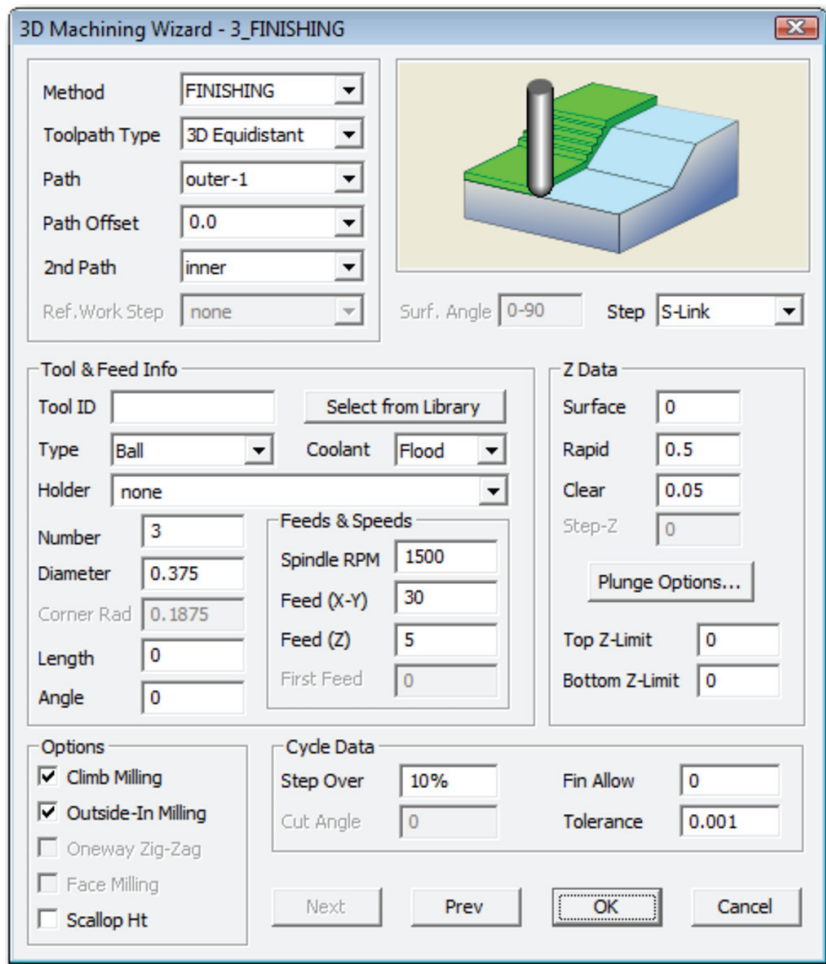

Picture 3-16



- Click the “Verify” button and the system starts calculating the toolpath. See **Picture 3-17**.



Verify

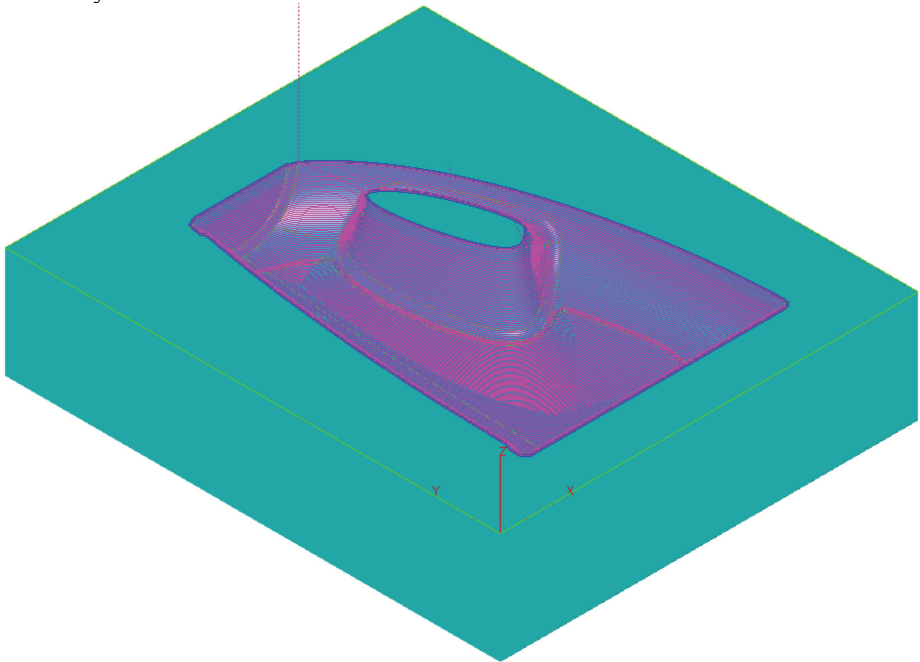

**Picture 3-17**

The Work Step #3 is now complete. Hit the “Redraw” button  to refresh the screen and remove the verified tool path display.



## CREATING WORK STEP “4\_RE-FINISHING”

In our last machining work step we will remove the material left in the areas with smaller indentation and concavity than the Finishing tool could complete. We will select the last finishing operation as the Reference Work Step and pick a relatively smaller tool. Then the system will automatically detect the uncut boundaries and generate a 3D Equidistant finishing toolpath.

1. Select the “3D Machining Wizard” command in the “Machining” menu or click the corresponding button.



3D Machining Wizard

2. Input “4\_RE-FINISHING” as the new Work Step ID. Confirm with OK.

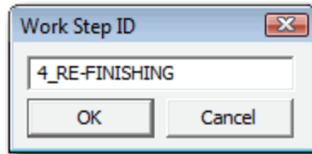

3. Select “RE-FINISHING” from the Method list box.

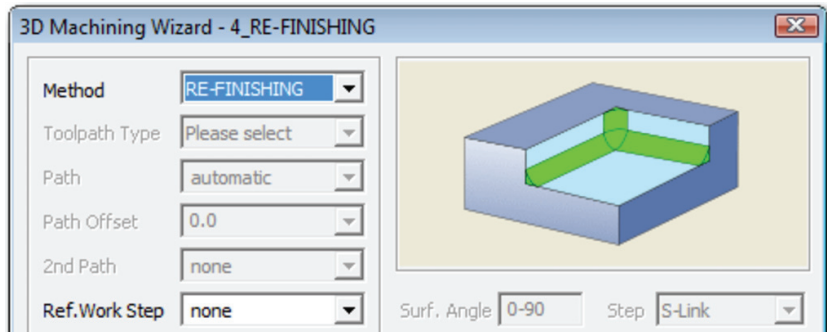

4. Select “3\_FINISHING” from the Ref. Work Step list box.

5. On the “3D Machining Wizard” window, change the settings according to the **Picture 3-18** below and ensure that all parameters are the same.

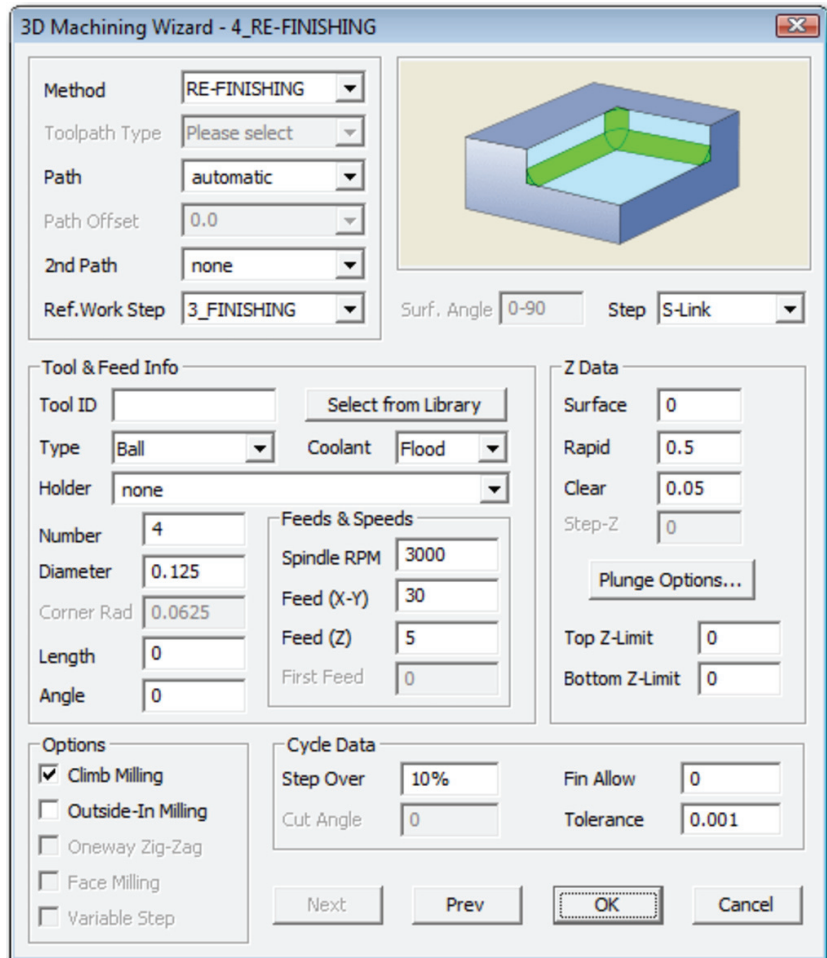

Picture 3-18

- Click the “Verify” button and the system starts calculating the toolpath. See **Picture 3-19**.



Verify

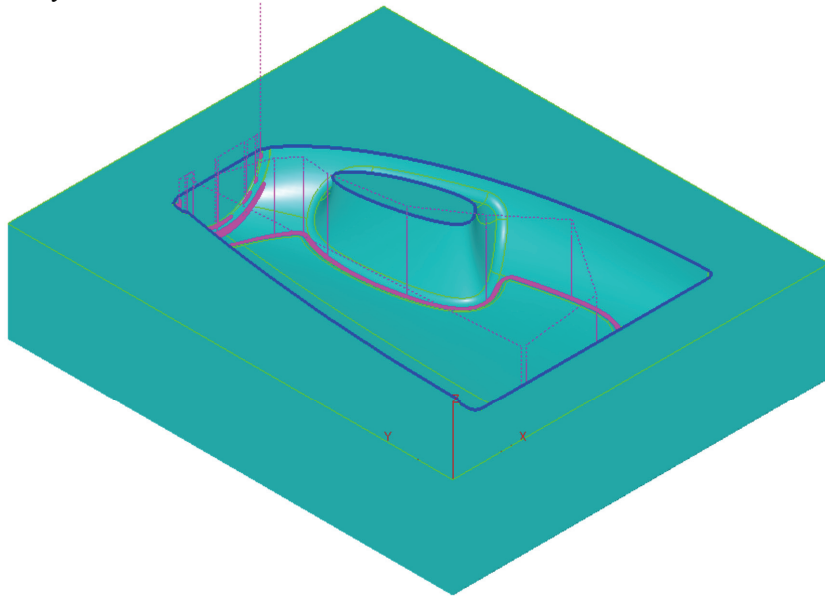

**Picture 3-19**

The Work Step #4 is now complete. Hit the “Redraw” button  to refresh the screen and remove the verified tool path display.

### 3D SOLID MODEL PREVIEW

One of the most powerful EZ-CAM features is the 3D solid preview function. This function shows an animated tool cutting a solid model of the programmed part. After previewing our program we are left with an accurate solid model representation, which allows us to closely examine the surface finish and resulting part details. If no stock was defined prior to calling the “3D Preview” or “RapidCut” commands, the system automatically calculates the stock size by adding a small margin to the sides and to the bottom of the visible solid model on the screen.

1. Select the “Stock & Optimization Setup” command from the “Machining” menu and click “Auto Setup”, values should appear as shown in **Picture 3-20**. You may also enter your own values if the stock is different from the solid model boundaries. Clicking and activating “Clash Detection” makes the system detect and warn you about the collisions between the tool and the stock. Also click “Save Simulation” to enable browsing through simulation results of each work step (see Paragraph – 4). Close the dialog with OK.

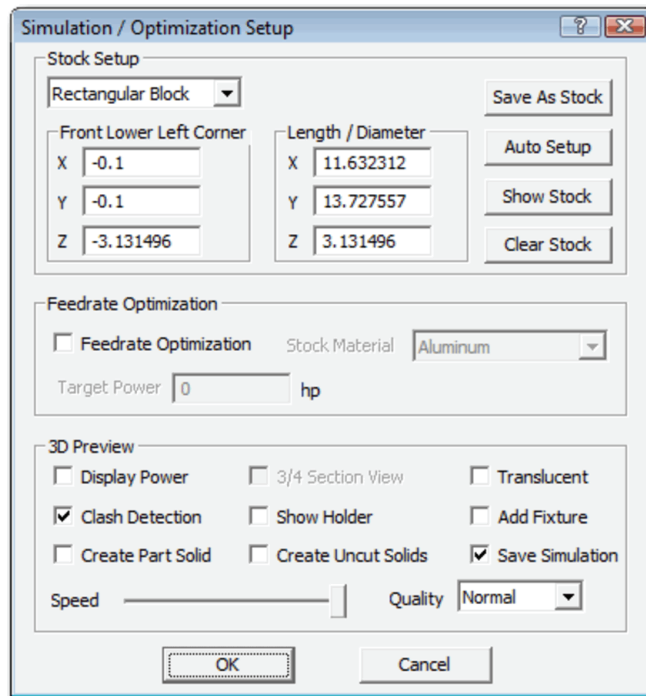

Picture 3-20



It is not necessary to open “Stock & Optimization Setup” window and run Auto Setup if you are executing the solid simulation for the “first time”, system calculates the stock boundaries automatically. But if somehow the stock size or position is improper at any time, you may need to run Auto Setup or input your own values that describe the real stock that will be mounted on the CNC machine.

If you need information about using custom stock for the solid simulation please refer to the Indexing section of the “EZ-MILL 4<sup>th</sup> Axis Tutorial”.

2. Start the simulation using “3D Preview” command from the “Machining” menu or the corresponding button. The simulation speed can be controlled any time by pressing one of the numeric keyboard buttons (not the ones on the num-pad side), ranging from 1 (slowest) to 9 (fastest). Pressing 0 will activate Step Mode. If you need to see the simulation result immediately, you can use “RapidCut” command by executing it from the “Machining” menu or the corresponding button. The simulation result is shown in **Picture 3-21**.



3D Preview

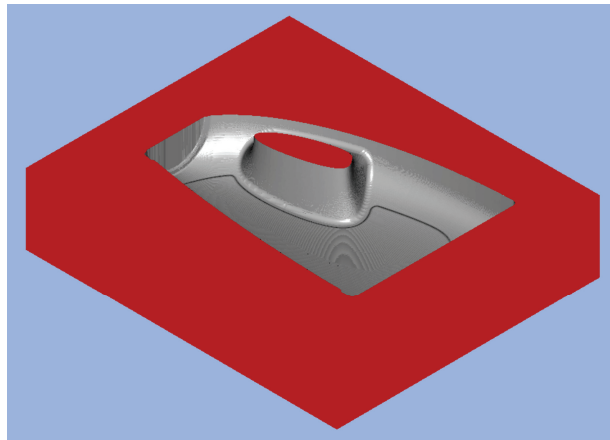

Rapid Cut

**Picture 3-21**

- During 3D simulation you can change the on-screen view by using the dynamic view commands (Rotate, Pan, Zoom) with their corresponding buttons. Alternatively you can activate rotate by holding down right button and pan by holding down middle button of the mouse while dragging it on the screen. As usual mouse wheel executes zoom command during the simulation as well.



Dynamic Rotate



Dynamic Zoom



Dynamic Pan

- After completing the 3D simulation it is possible to browse through the simulation results of each work step. Simply click the desired work step from the list box at the right side of the screen and EZ-CAM instantly shows the situation at the end of the selected work step. Click “2\_RE-ROUGHING” in the Work Step list box, you will see the simulation result at the end of second operation “re-roughing”. See **Picture 3-22**.

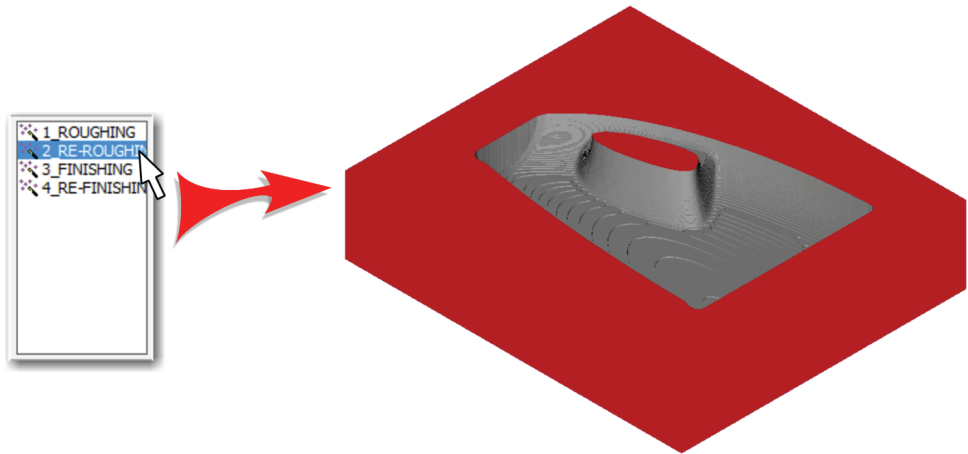

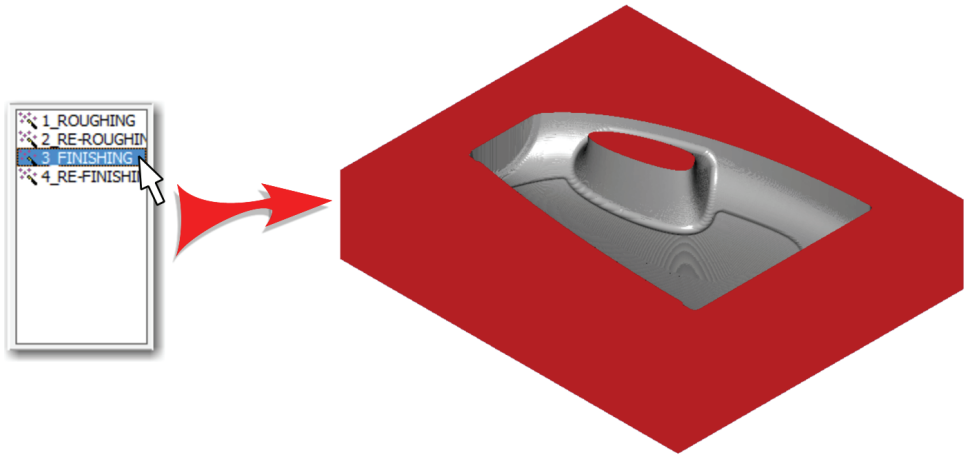

Picture 3-22

- Click “3\_FINISHING” in the Work Step list box, you will see the simulation result of the third operation “finishing”. See **Picture 3-23**.



**Picture 3-23**



Alternatively, after first clicking on one of the work steps in the list box you can use “up”  and “down”  arrow keys on the keyboard in order to browse through the simulation stages.

If you have returned to the CAD view and now want to see the simulation model at a specific work step (or to start simulation from the corresponding stage), use Recall Part command from “Machining” menu to view the model at the end of the active work step (that is selected in the list box) and then start simulation.

**Congratulations!**

**You've completed the EZ-MILL Pro 3D Machining Wizard Tutorial !**



# CHAPTER 4.

## EZ-TURN TUTORIAL

### OVERVIEW

This tutorial is intended for users with little, or no experience in EZ-TURN operations. The step-by-step instructions describe the complete process of creating the NC program for the part shown in **Picture 3-1**, focusing on the machining process and also describing advanced techniques used for roughing and finishing.

### BASIC PROGRAMMING STEPS

Before we continue with the tutorial let us explain the basic steps needed to create a part program with EZ-Turn.

- STEP 1. Create Geometry**  
Start by creating part geometry via commands under the Geometry Menu.
- STEP 2. Create Work Steps and set Machining Parameters**  
Define Work Steps for each machining operation and apply the parameters as required by type of operation and tool that is used. Create and assign a path curve to each Work Step. Visualize the computed tool path to assure correct tool operation and proper setting of machining parameters.
- STEP 3. Post G-Code**  
Select the “Postprocessor” related to the type of control and let the software create the G-Code file.



The EZ-Turn Tutorial is set up in Inch with all Inputs and Dimensions in Inch !

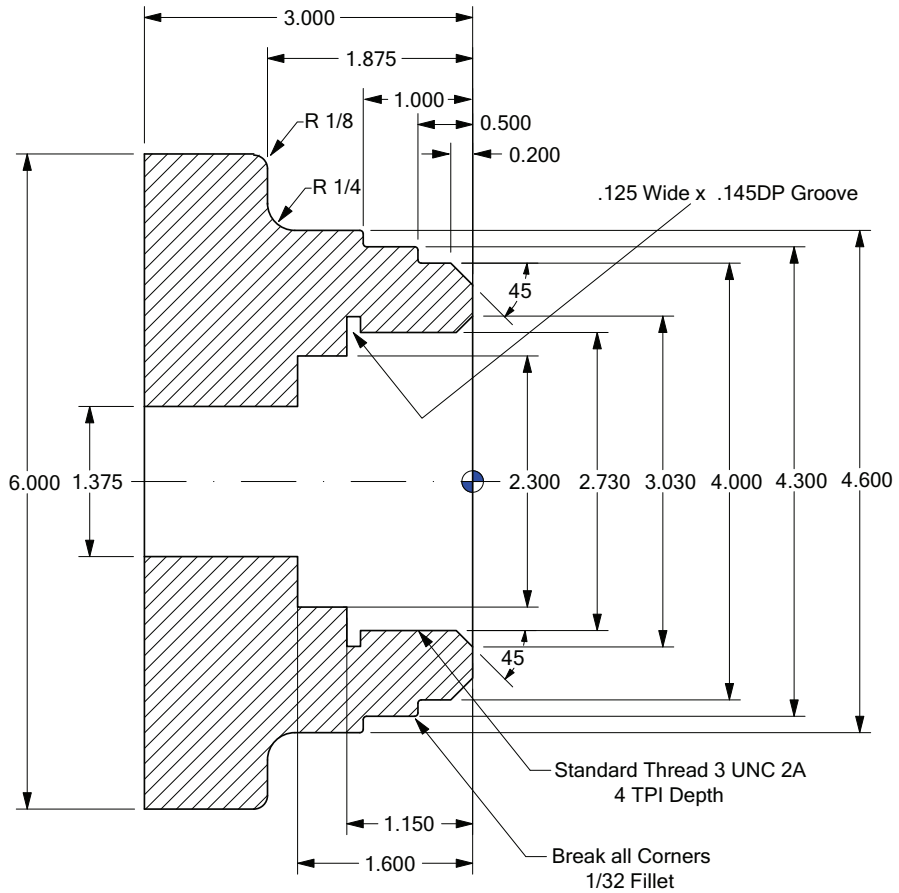

Blueprint of EZ-Turn Tutorial

Picture 4-1

## DEFINING ORIGIN, WINDOW SIZE AND LOCATION

The window size is the distance from the edge of the window to the center of the window. The window location is the signed, absolute position of the window center from the part's origin. The viewing parameters that are found in the Setup dialog box specify the size and location of the window. Note that you would not normally perform this step in programming a part, but it is necessary here to insure clarity in following the tutorial. Normally, you would just use the Zoom/Fade commands to set the window size as needed.

When selecting the origin for the part, choose a location that is referenced by the part's dimensions. The origin should be selected before defining the window location (see next topic for setting up the workspace), because the window center is referenced from the part's origin. The graphic in **Picture 4-2** below shows the location of the part origin for this exercise ( $X = -1.5$ ,  $Y = 1.5$ ).

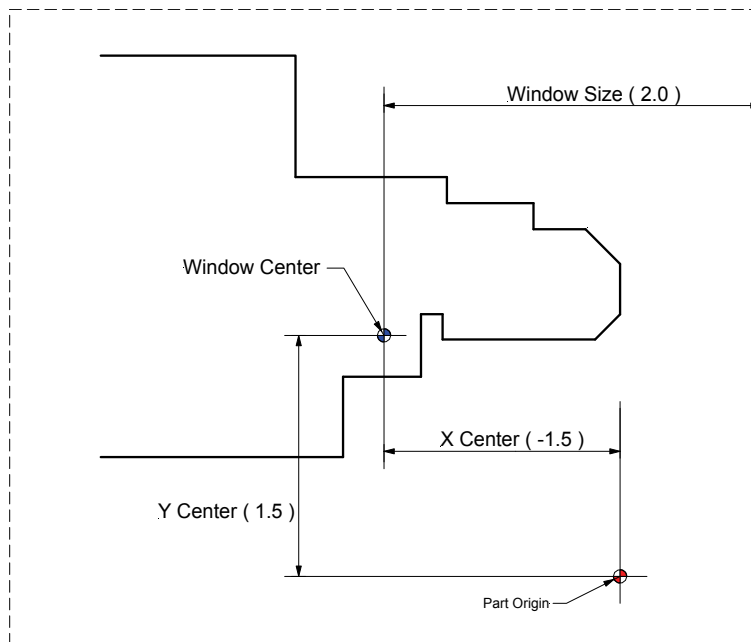

**Picture 4-2**

## SETTING PREFERENCES

Before continuing with the construction of the sample part, several parameters should be set so that the system is compatible with the instructions in this tutorial. Also the size of the workspace should be set. The sample part is about 3-inch in the Z-axis and 6-inch in the X-axis. Because of the size of the part, it is not convenient to work in the default window; therefore, the window and some default settings have to be changed.

1. Select "New" command from the "File" menu to restart EZ-CAM and the clear the memory before continuing with the tutorial. Make sure that the "TURN" button is activated before pressing OK to start over.

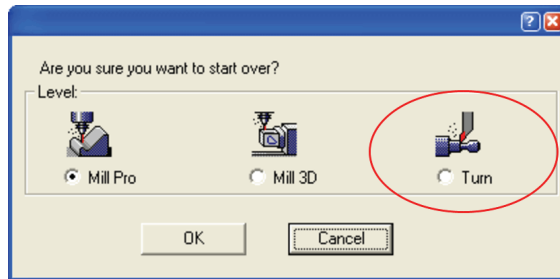

The "New" dialog is also used to switch between the EZ-Mill and EZ-Turn module. Before the dialog opens, the system checks the software protection key for activated modules. Modules or levels that are not activated will be marked by appended "DEMO" text. When working in "Demo" (evaluation) mode, it is not possible to print or save data. The corresponding "Save", "Save as" and "Print" commands are disabled.

When closing the EZCAM application, the system automatically stores the last used level as default for the next session.

2. Select "Setup" command from the "View" menu
3. Type "1.5" for "X Center", "-1.5" for "Y Center" and "2" for "Size". This sets the window size from the edge of the window to the center of the window, allowing enough room to see all of the part as it is created. See **Picture 4-2**.

4. Select “Inch” option button as the parts input dimension system.
5. Click the “Background” list box and select “Black”.
6. Select “Diameter Input” option button as the parts X-axis input system.
7. Disable “Enable Y coordinate entry” option.
8. Enable “Blank Verify”, “Show curve direction” and “Save as default” options. Then close the dialog with OK button.

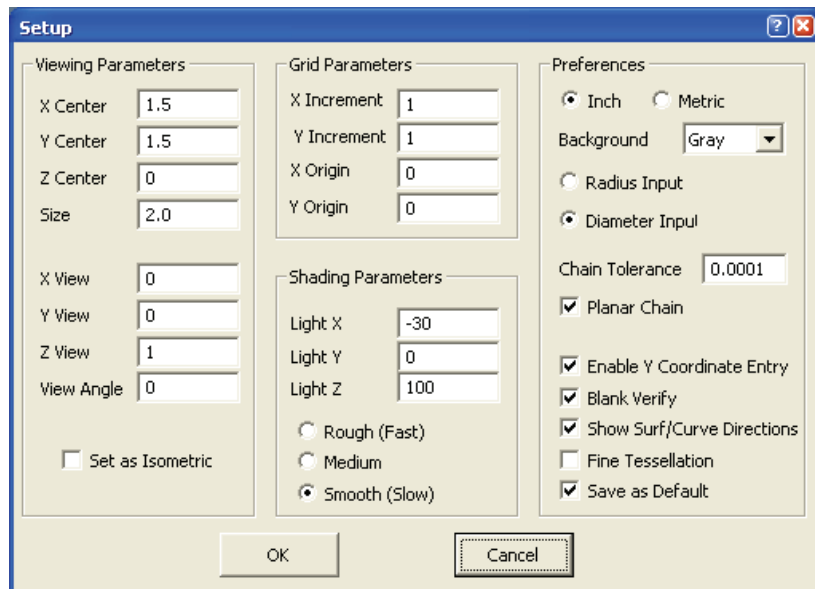

Picture 4-3

The initial setup for the TURN tutorial is now complete. Continue with the next section to create the geometry necessary for this part.

## THE PART GEOMETRY

Now that the workspace has been adjusted to accommodate the part, the creation of the part can begin. This involves creating geometry that is used to define the path curves for machining the part. The geometry is created first, so that the process of creating the curves is greatly simplified.

First, we will define the basic geometry that defines the outside contour of the sample part. Then we continue with inserting the various fillets. At any time you may use the Undo/Redo buttons in the upper left corner to correct any mistakes you make.

1. Select the “Connected Lines” command from the “Geometry” menu or click the corresponding button on the toolbar.



Connected  
Lines

2. EZ-TURN prompts you to pick the first point. Type “-3” in the “Z” field of the Value Entry Box. Then press Tab to move the focus to the “X” input field. Type “1.375” for the X location and press the ENTER button to confirm the first point.

	Z	X
P1	-3.0	1.375

3. Continue entering the Z and X values for points #2 to #17 as listed in the table below. Press ENTER for each point to confirm the Z and X input. When finished the part geometry should appear as in Picture 4-4.

	Z	X
P2	-1.6	1.375
P3	-1.6	2.3
P4	-1.15	2.3
P5	-1.15	3.02
P6	-1.025	3.02
P7	-1.025	2.73

	Z	X
P8	-0.15	2.73
P9	0	3.03
P10	0	3.6
P11	-0.2	4.0
P12	-0.5	4.0
P13	-0.5	4.3
P14	-1.0	4.3
P15	-1.0	4.6
P16	-1.875	4.6
P17	-1.875	6.0
P18	-3.0	6.0

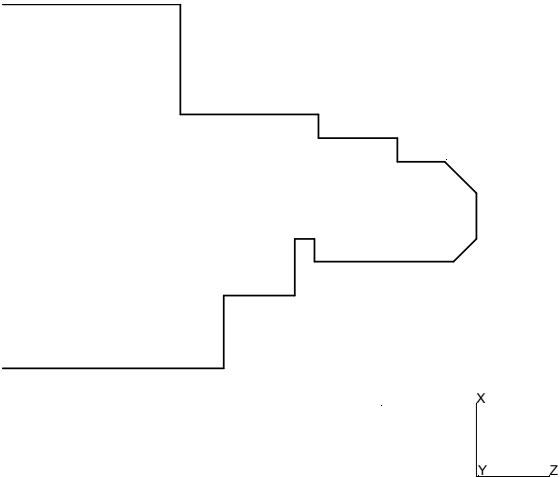

Picture 4-4

## CREATING FILLETS

Follow the instructions below to create corner fillets for the sample part.

1. Select the “Corner Fillet” command from the “Geometry” menu or click the corresponding button on the toolbar.



Corner Fillet

2. Type “1/32” or “0.03125” in the “R” field of the Value Entry Box. This sets the radius for the corner fillet at 1/32". Place and click the cursor at each position shown in **Picture 4-5**.

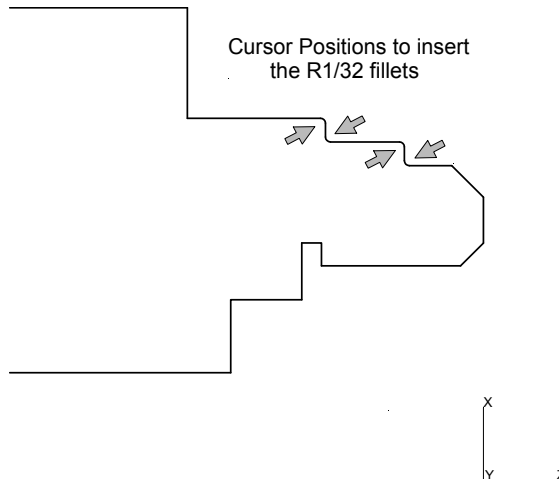

Picture 4-5

4. Type “0.25” for the 1/4-inch fillet in the “R” field of the Value Entry Box and click the cursor at the position shown on **Picture 4-6**.



5. Type “0.125” for the 1/8-inch fillet in the “R” field of the Value Entry Box and click the cursor at the position shown on **Picture 4-6**.

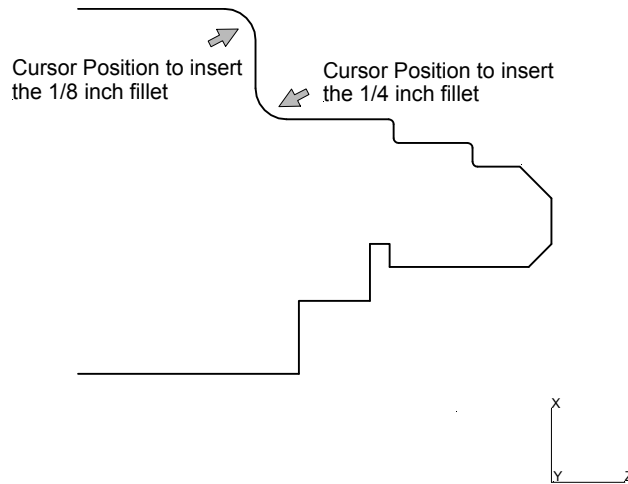

**Picture 4-6**



If you want to save the newly created geometry before continuing, jump to the “Saving the Part” section at the end of the EZ-TURN tutorial.

## CREATING THE PART PROGRAM

Now as the geometry for the Turn tutorial is completed we continue with creation of the Work Steps necessary to machine the part. Select the desired cycle (Profile, Turn, Bore, etc.), specify associated tool settings and machining parameters and define the path representing the profile to be machined. Finally verifying the calculated tool path assures correct tool operation. When all necessary Work Steps have been defined, the complete part program can again be verified for visual checks. If everything is ok continue to the next step and create the CNC-Code.



During Work Step creation you will see dialogs that display many parameters and settings. As it is simply not possible to give detailed information on every parameter within this tutorial you may use the integrated context sensitive “What’s This?” help function to get a brief description on any desired dialog item.



Simply select the “?” button in the upper right of the dialog and click on any parameter label or dialog section. The information will be displayed in a separate window as shown below.

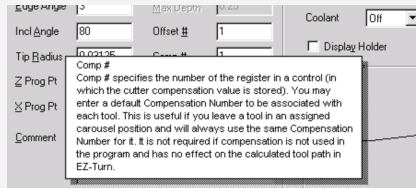

**The part program of the tutorial will consist of these 8 Work Steps:**

1. Face the front surface.
2. Turn the exterior surfaces and allow stock for the finishing operation.
3. Profile the exterior to a finished surface.
4. Drill the center of the part.
5. Bore the inner surface to two different diameters, allowing stock for the finishing operation.
6. Profile the interior drilled and bored surfaces to the finish ID's.
7. Create a Groove to allow for thread tool retraction.
8. Thread the ID at 4 TPI (threads per inch).



Execution of the Work Steps will be in the same order they have been created. You can use the integrated spreadsheet to perform operations such as moving, reordering or deleting existing Work Steps.

See the “Spreadsheet” book in the online help for more detailed information.

## CREATING WORK STEP #1 (FACE MACHINING)

Now we create the first Work Step selecting a facing cycle that will take a small amount of material off the stock to make it an even surface.

1. Select the “Work Step Data” command in the “Machining” menu to open the “Work Step Data” dialog. Once it is open switch to the “Tool Info” tab.

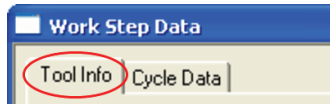

2. Press the “New” button and input “1-Face” as the new Work Step ID and confirm with OK (1 identifies the Work Step number, and FACE is simply a description of the purpose of the Work Step).

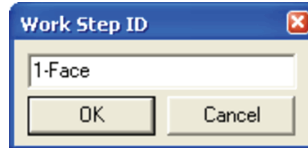

3. Select “Face” from the cycle list.

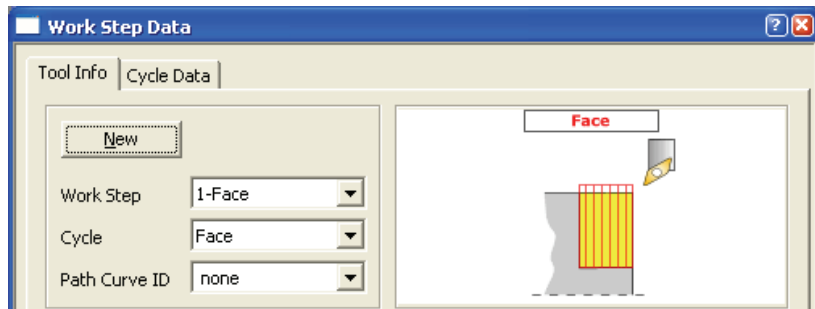

4. Now we select a tool. For this click the “Select Tool” button from the “Tool Info” tab to open the “Select Tool” dialog box. If there are no tools available select the “Change” button to load the “INCHTOOL.TLS” database from the “EZCAMW \ EZCAM..” directory. “EZCAM..” stands for the directory of the currently installed software release (EZCAM12, EZCAM13, etc.). This tool library has all tools needed for the tutorial.

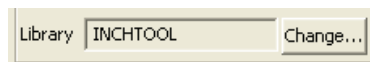

Once the database is loaded highlight the tool ID “301” (80 degree diamond insert, tip radius 0.03125) and click the “Select” button as shown in **Picture 4-7**.

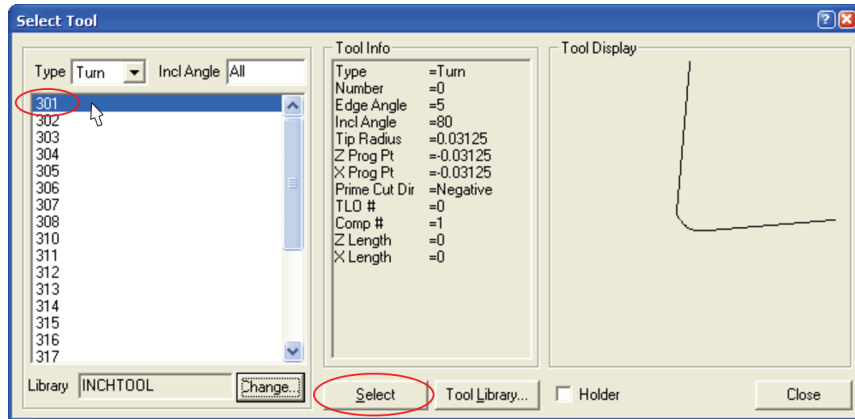

**Picture 4-7**

- As we are already on the “Tool Info” tab, change the dialog settings as shown in the table below. See **Picture 4-8** for the full dialog.

Dialog Field	Value	Comment
Number	1	This number represents the tool position on the tool turret / magazine.
Offset #	1	Specifies the register number on the control were the current tool's offset compensation values are stored.
Z Index	5	Tool change position for Z axis
X Index	10	Tool change position for X-axis
Coolant	FLOOD	

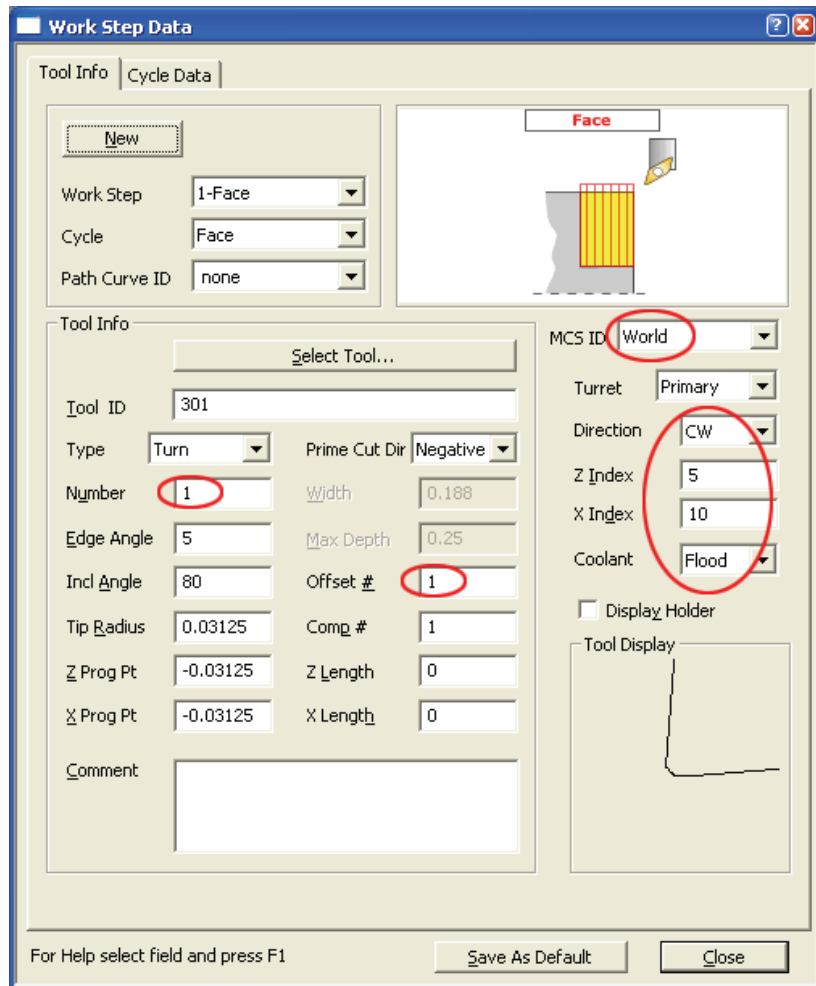

Picture 4-8

6. Now select the “**Cycle Data**” tab and change settings according to the table below. Close the dialog using the “**Close**” button. See **Picture 4-9**.

Dialog Field	Value	Comment
Z Fin Allow	0	Finish allowance for the X / Z-axes.
X Fin Allow	0	
Clear	0.05	Clearance distance between material boundary and tool tip at the start of the cycle.
Withdraw Angle	45	Angle applied to retract move at the end of each roughing pass.
Withdraw Length	0.05	Length of retract move at the end of each roughing pass.
Depth	0.1	Incremental depth increment for each pass.
CSS Status	ON	When constant surface speed is set to ON, the machine tool automatically adjusts the RPM to maintain the specified CSS value.
CSS Value	400	Sets constant surface speed (feed / minute).
Max RPM	2500	Sets maximum spindle RPM if CSS ON.
Feed Units	UPR	Sets Feed Rate type to <b>Units Per Round</b> .
Feed Rate	0.025	Feedrate rough passes
Engage Feed	0.05	Feedrate depth moves
Withdraw Feed	0.05	Feedrate retract moves
Stock Curve	Manual	Stock curve defined manual. Roughing boundaries specified by the Inner/Outer-Diameter and Left/Right-Boundary as listed below.
Inner Dia	0	Inside stock diameter
Outer Dia	6.0	Outside stock diameter
Left Bound	0	Absolute Z position for left stock boundary
Right Bound	0.3	Absolute Z position for right stock boundary

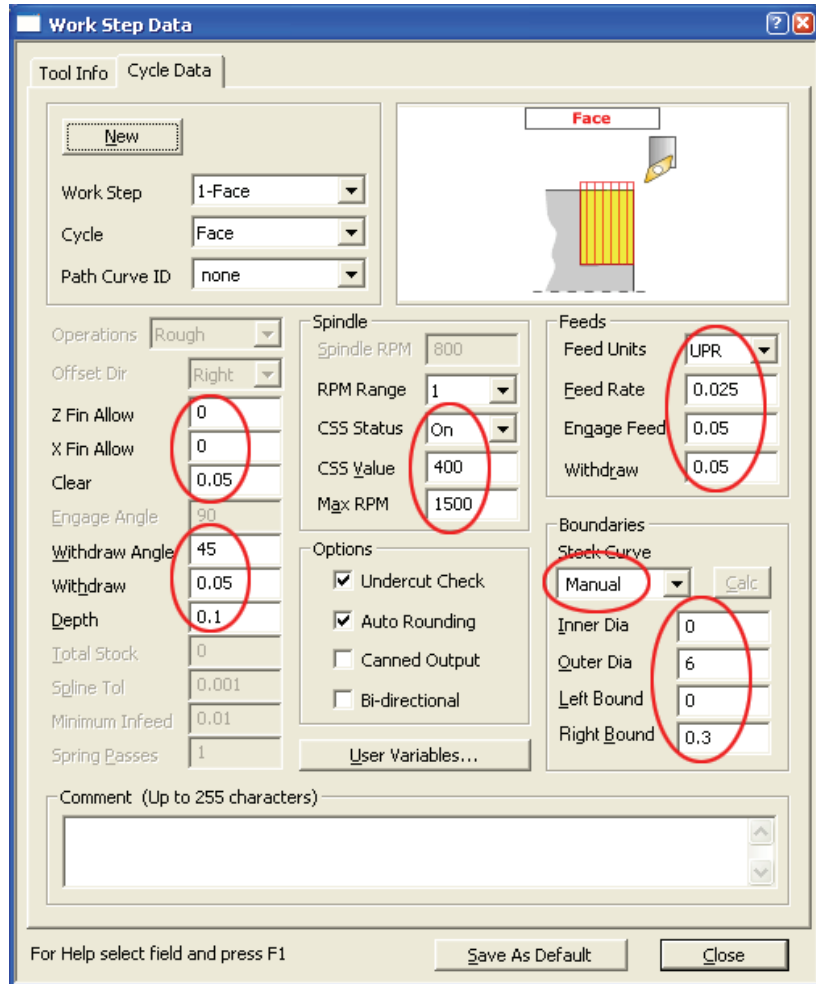

Picture 4-9



## CREATING TOOL PATH FOR WORK STEP #1

Now that all of the machining parameters have been defined, a path curve must be created. EZ-Turn uses the curve entity to define a cutter path for each machining Work Step.

1. Select the “New” command from the “Curves” menu or click the corresponding button. In the dialog that opens type “Crv1-Face” as the new ID and confirm with OK (Crv1 is the systems default ID and FACE is simply a description of the purpose of the curve).



New

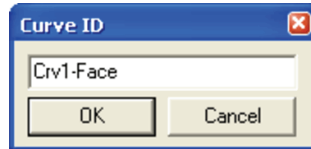

2. Select the “Linear” command from the “Curves” menu or click



Linear

3. The curve for this Work Step will consist of only one single linear move. To define the first point type “0” in the “Z” field of the Value Entry Box. Press Tab to move the focus to the “X” input field. Type “6” for the X location and press the ENTER button to confirm the first point. A small triangle is displayed on the screen.
4. For the second point type “0” for the X location (“Z” is already “0”) and press the ENTER button to confirm the second point. A blue line representing the new curve is now visible on the screen
5. Now we assign the new curve to the previously created Work Step. If you look at the Path Status button at the bottom of the screen, you’ll see that there is no curve ID displayed indicating that no tool path has been assigned to the current Work Step.

Click the “Path” status button and select the Curve ID “Crv1-Face” from the Selection List Box. The status button will now show the ID of the selected curve.

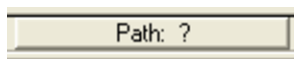

Path Status Button

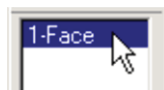

Selection List Box





Path Status Button displaying curve selected for the current Work Step

- Click the “Verify” button to calculate and display the tool path on the screen as shown in **Picture 4-10**.

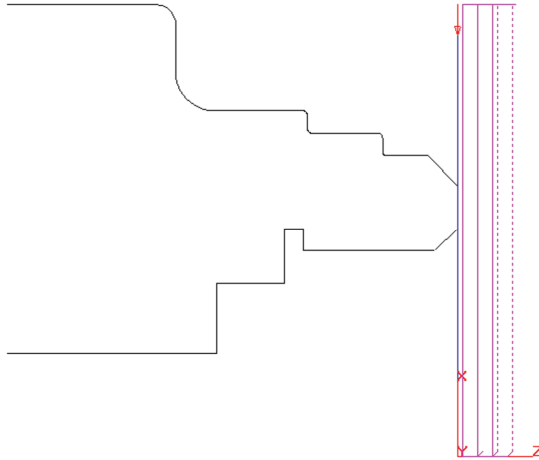

Verify

**Picture 4-10**

The Work Step #1 is now complete. Hit the “Redraw” button  to refresh the screen and remove the verified tool path display.

## CREATING WORK STEP #2 (TURNING CYCLE)

The next step in creating the part program is to set up the turning cycle that turns down the exterior surfaces.

1. Click the Work Step Data button to open the “Work Step Data” dialog and select the “Tool Info” tab.



2. Press the “New” button and input “2-Turn” as the new Work Step ID and confirm with OK.

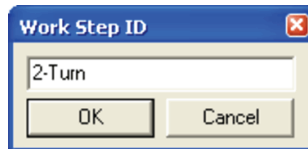

3. Select “Turn” from the cycle list. Don’t worry about the currently selected path curve. This will be changed later.

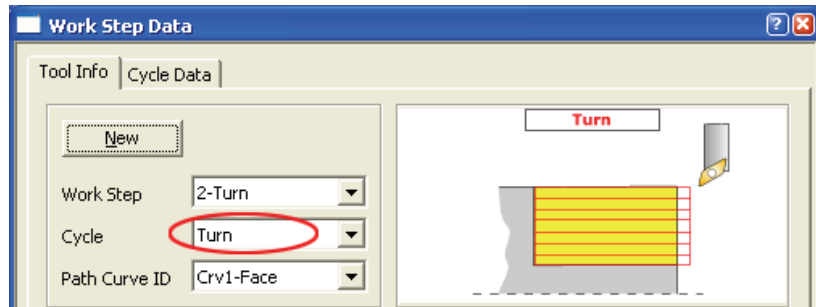

4. Ensure that all parameters on the “**Cycle Data**” tab are set as listed in the table below. Other settings (also on “Tool Info” tab) are identical to the previous Work Step. Close the dialog using the “**Close**” button.

Dialog Field	Value	Comment
Z Fin Allow	0.005	The “Fin Allow” settings specify separate finish allowance values for the X and Z axes
X Fin Allow	0.01	

Clear	0.1	Clearance distance between the material boundary and the tool tip at the start of the cycle.
Withdraw Angle	45	Angle applied to retract move at the end of each roughing pass.
Withdraw Length	0.025	Length of move when retracting at the end of each roughing pass.
Depth	0.075	Depth increment for each pass of roughing routine.
Inner Dia	0	Inside stock diameter
Outer Dia	6.0	Outside stock diameter
Left Bound	-3.0	Absolute Z position for left stock boundary
Right Bound	0	Absolute Z position for right stock boundary

## CREATING TOOL PATH FOR WORK STEP #2

1. Select the “New” command from the “Curves” menu or click the corresponding button. In the dialog that opens type “Crv2-Turn” as the new ID and confirm with OK.



New

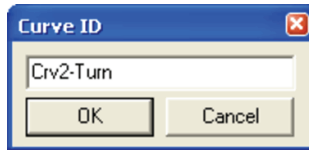

2. Select the “Chain” command from the “Curves” menu or click the corresponding button.



Chain

- The prompt “Pick first line, arc, circle, or point figure” is displayed at the bottom edge of the window. Move the cursor to the position shown in **Picture 4-11** and double-click the mouse to select the line as the first element in the curve chain. The software automatically completes the curve by following the connected geometry elements from the first point to the last. A small arrow referred to as the “direction indicator” visualizes the curve direction.

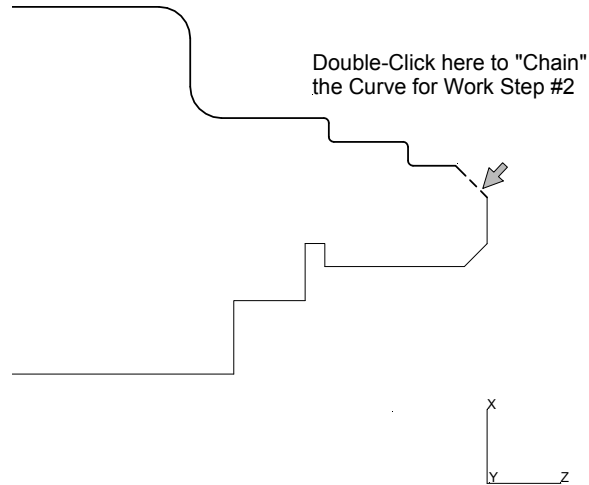

**Picture 4-11**



In case path chaining failed for some reason (selected wrong element or position), simply delete any already existing path elements by using the “Delete All Links” command from “Curves” menu. Then select “Chain” command and try again.

- To assign the new curve to the previously created Work Step press the “Path” status button and select the Curve ID “Crv2-Turn” from the Selection List Box. The status button will now show the ID of the selected curve.



5. Click the “Verify” button to calculate and display the tool path on the screen as shown in **Picture 4-12**.



Verify

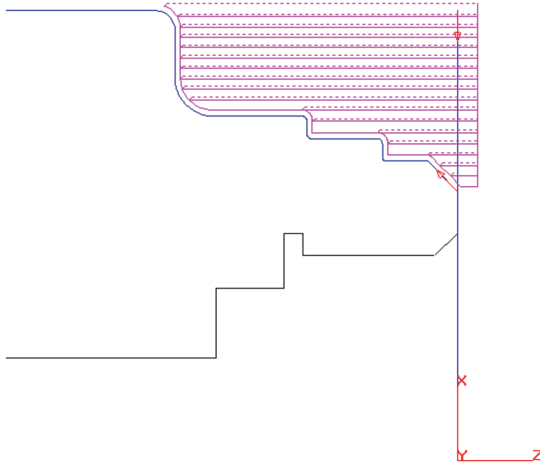

**Picture 4-12**

The Work Step #2 is now complete. Hit the “Redraw” button  to refresh the screen and remove the verified tool path display.

### CREATING WORK STEP #3 (PROFILING CYCLE)

The profiling cycle is a finishing operation to reduce the roughening caused by the turning path. We select a new tool and assign specific finishing parameters. The same path curve as in the previous Work Step will be used.

1. Click the Work Step Data button to open the “**Work Step Data**” dialog and select the “**Tool Info**” tab.

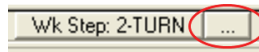

2. Press the “**New**” button and input “**3-Profile**” as the new Work Step ID and confirm with OK.

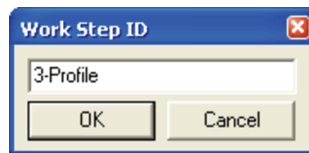

3. Select “**Profile**” from the cycle list. As the previous Work Step curve is automatically copied when a new Work Step is created the “**Path ID**” field should already show “**Crv2-Turn**”.

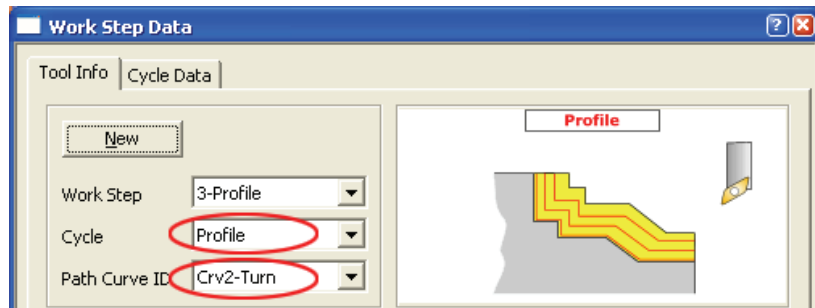

4. Click the “**Select Tool**” button from the “**Tool Info**” tab to open the “**Select Tool**” dialog box. Highlight the tool ID “**304**” (60 degree diamond insert, tip radius 0.016) from the list and click the “**Select**” button to load the tool.
5. On the “**Tool Info**” tab, change the settings as shown in the table below.

Dialog Field	Value	Comment
Number	2	Tool number on the tool turret / magazine.
Offset #	2	Tool's offset register number.

6. On the “**Cycle Data**” tab ensure that the parameters listed below are set correctly. Close the dialog using the “**Close**” button.

Dialog Field	Value	Comment
Offset Dir	RIGHT	This setting controls how the tool is placed in relation to the path. The direction is always determined by looking in the cutting direction (path direction) from behind the tool.
Z Fin Allow	0	Finish allowance for the X and Z-axes.
X Fin Allow	0	
Feed Rate	0.005	Feedrate finish pass.

7. Click the “Verify” button to calculate and display the tool path on the screen as shown in **Picture 4-13**.



Verify

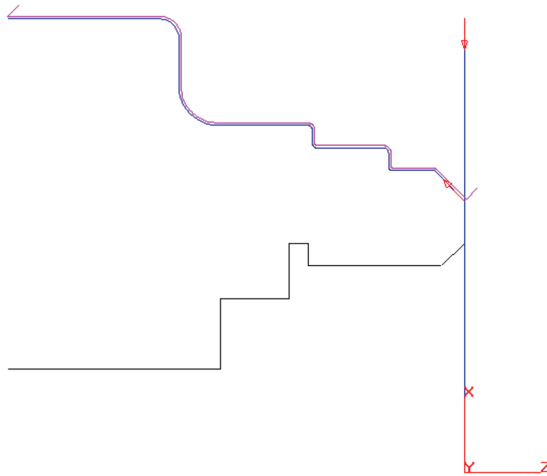

**Picture 4-13**

The Work Step #3 is now complete. Hit the “Redraw” button  to refresh the screen and remove the verified tool path display.



## CREATING WORK STEP #4 (DRILLING CYCLE)

The purpose of this cycle is to drill through the center of the part, to allow for the thread and groove creation later in the part program.

1. Click the Work Step Data button to open the “Work Step Data” dialog and select the “**Tool Info**” tab.



2. Press the “New” button and input “4-Drill” as the new Work Step ID and confirm with OK.

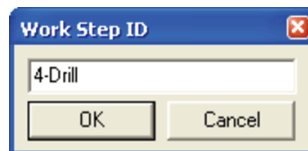

3. Select “Drill” from the cycle list. Don’t worry about the “Path ID” field still showing “Crv2-Turn”. We will create and assign a new path curve later.

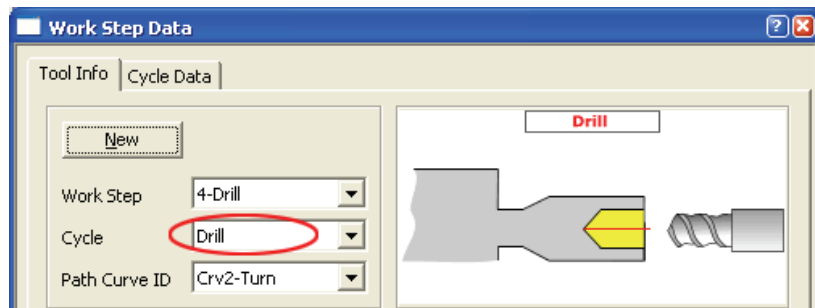

4. Click the “Select Tool” button from the “Tool Info” tab to open the “Select Tool” dialog box. Select “Drill” from the “Type” list box to list drill tools only. Click the tool ID “Drill1375” (1.375 diameter, 120 degree included tip angle) from the list and pick the “Select” button to load the tool.
5. On the “**Tool Info**” tab, change the settings as shown in the table below.

Dialog Field	Value	Comment
Number	3	Tool number on the tool turret / magazine.
Offset #	3	Tool’s offset register number.

6. On the “**Cycle Data**” tab ensure that the parameters listed below are set correctly. Close the dialog using the “**Close**” button.

Dialog Field	Value	Comment
Operations	Drill	Standard drilling operation
Clear	0.05	Clearance distance between the material boundary and the tool tip at the start of the drill cycle.
Depth	3.4	Total depth increment for the DRILL cycle (3.0 + tooltip length).
Step 1	0.5	First peck increment.
Step 2	0.25	Second and subsequent peck increments, step 2-n.
Spindle RPM	800	Sets constant speed to 800 rpm/ minute.
CSS Status	OFF	Set constant surface speed to OFF for switching to constant spindle RPM.
Feed rate	0.005	Feed rate for drilling moves

#### CREATING TOOL PATH FOR WORK STEP #4

The drill cycle curve requires only one point for its path definition. The “Depth” parameter from the “Cycle Data” tab will be referenced from this point.

1. Select the “New” command from the “Curves” menu or click the corresponding button. In the dialog that opens type “Crv4-Drill” as the new ID and confirm with OK.



New

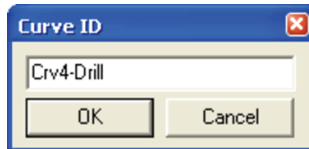

2. To create the path click the “Linear” button or select the command in the “Curve” menu.



Linear

3. The curve for this Work Step will consist of only one single point that reflects the starting point of the drilled hole. Type “0” in the “Z” and “X” fields of the Value Entry Box to specify the center location. Press ENTER to confirm the point. A small triangle is displayed on the screen.
4. Now we have to assign the new curve to the previously created Work Step. Click the “Path” status button and select the Curve ID “Crv4-Drill” from the Selection List Box. The status button will now show the ID of the selected curve.

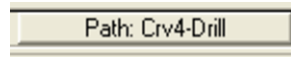

5. Click the “Verify” button to calculate and display the tool path on the screen as shown in **Picture 4-14**.



Verify

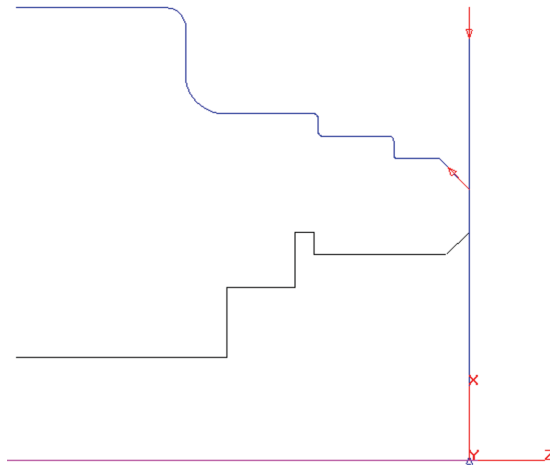

**Picture 4-14**

The Work Step #4 is now complete. Hit the “Redraw” button  to refresh the screen and remove the verified tool path display.

### CREATING WORK STEP #5 (BORING CYCLE)

Now that the drilling cycle has been verified, the boring cycle must be created to bore the three different inside dimensions.

1. Click the Work Step Data button to open the “Work Step Data” dialog and select the “Tool Info” tab.



2. Press the “New” button and input “5-Bore” as the new Work Step ID and confirm with OK.

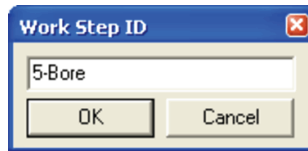

3. Select “Bore” from the cycle list. Don’t worry about the “Path ID” field still showing “Crv4-Drill”. We will create and assign a new curve later.

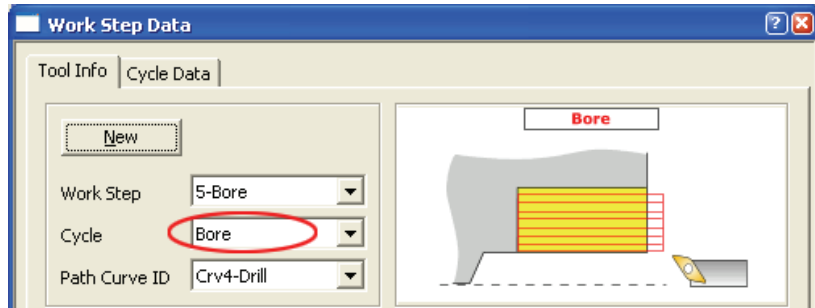

4. Click the “Select Tool” button from the “**Tool Info**” tab to open the “Select Tool” dialog box. Select “Bore” from the “Type” list box to list bore tools only. Highlight the tool ID “403” (60 degree diamond insert, tip radius 0.032) from the list and click the “Select” button to load the tool.
5. On the “Tool Info” tab, change the settings as shown in the table below.

Dialog Field	Value	Comment
Number	4	Tool number on the tool turret / magazine.
Offset #	4	Tool’s offset register number.

6. On the “Cycle Data” tab ensure that the parameters listed below are set correctly. Close the dialog using the “Close” button.

Dialog Field	Value	Comment
Z Fin Allow	0.005	Finish allowance for the X and Z axes
X Fin Allow	0.01	
Clear	0.1	Clearance between boundary and tool tip.
Withdraw Length	0.025	Length of retract move.
Depth	0.1	Depth increment for each roughing pass.
CSS Status	ON	Activate Constant surface Speed (feed/min).
CSS Value	400	Constant surface speed (feed / minute).
Max RPM	2500	Sets maximum spindle RPM if CSS ON.
Feed Units	UPR	Sets Feed Rate type to <b>Units Per Round</b> .
Feed Rate	0.025	Feedrate rough passes
Engage Feed	0.05	Feedrate depth moves
Withdraw Feed	0.05	Feedrate retract moves
Stock Curve	NONE	NONE=No stock curve defined. Roughing boundaries specified by the Inner/Outer-Diameter and Left/Right-Boundary as listed below.
Inner Dia	1.375	Inside stock diameter
Outer Dia	2.0	Outside stock diameter
Left Bound	-1.6	Absolute Z position for left stock boundary
Right Bound	0	Absolute Z position for right stock boundary

## CREATING TOOL PATH FOR WORK STEP #5

The tool path creation for the boring cycle is going to make use of the Pick “Intersection of Two” button. This will allow for the bore to be completed while ignoring the groove previously established in the geometry.

1. Select the “New” command from the “Curves” menu or click the corresponding button. In the dialog that opens type “Crv5-Bore” as the new ID and confirm with OK.



New

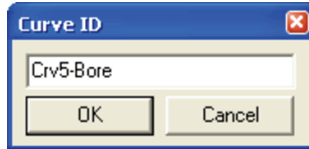

2. Select “Linear” from the “Curve” menu, then switch to the “Endpoint” pick mode from the “Edit/Point Picking” menu. You may also use the corresponding toolbar buttons.



Linear



Pick Endpoint

Click the cursor on position #1 and #2 as shown in **Picture 4-15** to create the first linear move of the new curve.

3. Switch to the “Intersection of Two” pick mode from the “Edit/Point Picking” menu or use the corresponding button. The “Linear” curve command is still activated.

Intersection  
of Two

Click the cursor on positions #3 and #4 as shown in **Picture 4-15** to select the two lines from the geometry. The system automatically snaps to the intersection of both elements and creates the third point of the curve.

4. Switch back to “Endpoint” pick mode and click the cursor on positions #5, #6 and #7 as shown in **Picture 4-15** to finish the curve creation.



Pick Endpoint

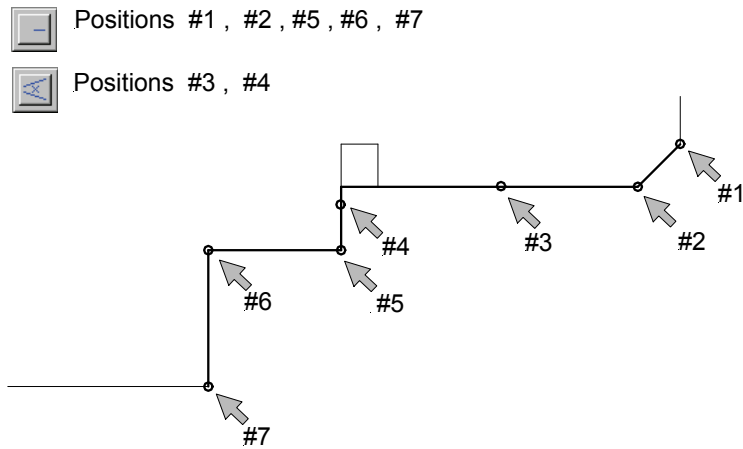

**Picture 4-15**

- As the last element of this curve we will append a rapid move to cause the tool to retract to a safe position before moving to the tool change location. Select the “Rapid” command from the “Curves” menu. Type “0.25” in the “Z” field and “1.2” to the “X” field of the Value Entry Box. Press ENTER to confirm the input. The rapid move is displayed as a dotted line.



Rapid

- To assign the new curve to the previously created Work Step click the “Path” status button and select the Curve ID “Crv5-Bore” from the Selection List Box.



- Click the “Verify” button to calculate and display the tool path on the screen as shown in **Picture 4-16**.



Verify

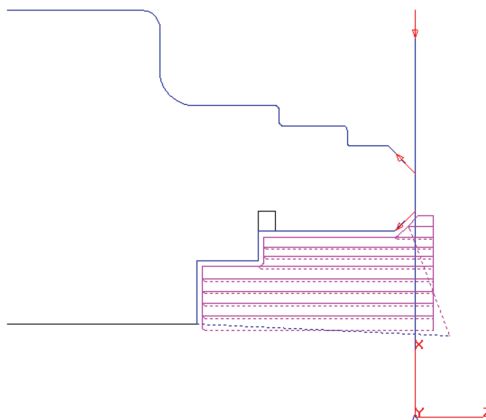

**Picture 4-16**

The Work Step #5 is now complete. Hit the “Redraw” button  to refresh the screen and remove the verified tool path display.



## CREATING WORK STEP #6 (PROFILING CYCLE)

The next machining cycle is a profiling cycle of the previously bored surfaces.

1. Click the Work Step Data button to open the “Work Step Data” dialog. Once it is open switch to the “Tool Info” tab.



2. Press the “New” button and input “6-Profile” as the new Work Step ID and confirm with OK.

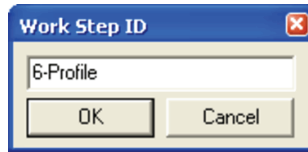

3. Select “Profile” from the cycle list. As the previous Work Step curve is automatically copied when a new Work Step is created the “Path ID” field should already show “Crv5-Bore”.

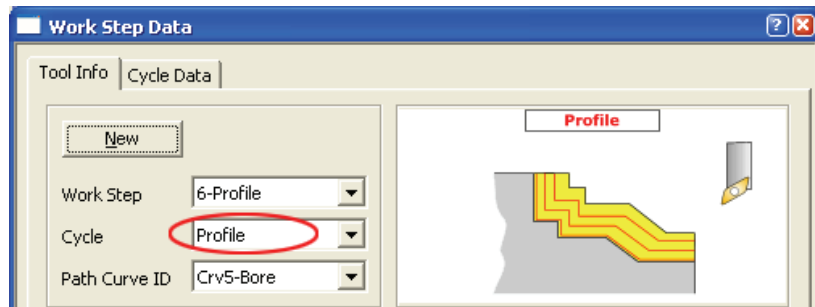

4. Click the “Select Tool” button from the “**Tool Info**” tab to open the “Select Tool” dialog box. “Bore” tool type should still be active. Highlight the tool ID “407” (55 degree diamond insert, tip radius 0.016) from the list and click the “Select” button to load the tool.
5. On the “Tool Info” tab, change the settings as shown in the table below.

Dialog Field	Value	Comment
Number	5	Tool number on the tool turret / magazine.
Offset #	5	Tool’s offset register number.

6. On the “Cycle Data” tab ensure that the parameters listed below are set correctly. Close the dialog using the “Close” button.

Dialog Field	Value	Comment
Offset Dir	LEFT	This setting controls how the tool is placed in relation to the path. The direction is always determined by looking in the cutting direction (path direction) from behind the tool.
Z Fin Allow	0	Finish allowance for the X and Z-axes.
X Fin Allow	0	
Clear	0.05	Clearance between boundary and tool tip.
Engage Angle	0	Angle applied to engage move
Withdraw Angle	180	Angle applied to retract move
Feed Rate	0.005	Feedrate finish pass.

- Click the “Verify” button to calculate and display the tool path on the screen as shown in **Picture 4-17**.



Verify

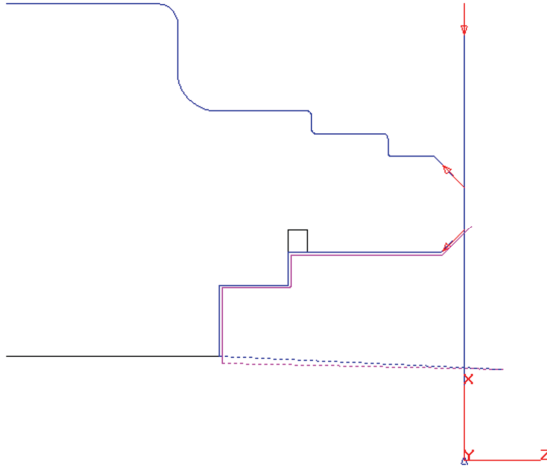

**Picture 4-17**

The Work Step #6 is now complete. Hit the “Redraw” button  to refresh the screen and remove the verified tool path display.

### CREATING WORK STEP #7 (GROOVING CYCLE)

The purpose of this cycle is to create a groove so that the tool can be retracted after the threads are created. It produces a rough finish that does not need to be profiled.

1. Click the Work Step Data button to open the “Work Step Data” dialog. Once it is open switch to the “Tool Info” tab.



2. Press the “New” button and input “7-Groove” as the new Work Step ID and confirm with OK.



3. Select “Groove” from the cycle list. The path curve will be assigned later.

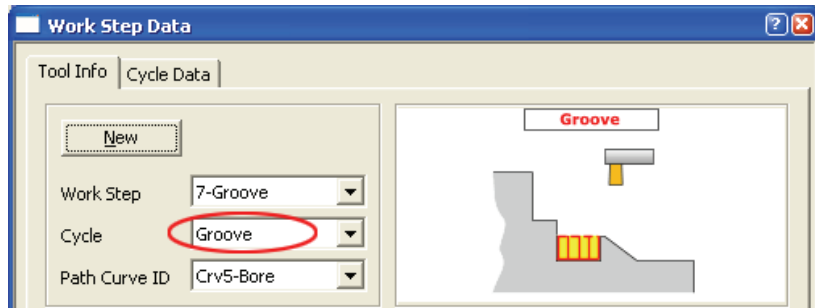

4. Click the “Select Tool” button from the “Tool Info” tab to open the “Select Tool” dialog box. Select “Groove” from the “Type” list box. Click the tool ID “551” (0.125 width, tip radius 0.005, max. depth 0.25) from the list and press the “Select” button to load the tool.
5. On the “Tool Info” tab, change the settings as shown in the table below.

Dialog Field	Value	Comment
Number	6	Tool number on the tool turret / magazine.
Offset #	6	Tool’s offset register number.

6. On the “Cycle Data” tab ensure that the parameters listed below are set correctly. Close the dialog using the “Close” button.

Dialog Field	Value	Comment
Operations	ROUGH+FIN	When using “Rough + Fin” option, the groove is rough machined first and finally cleaned up with a finishing pass including the bottom of the groove.
Offset Dir.	LEFT	This setting controls how the tool is placed in relation to the machined path. The direction is always determined by looking in the cutting direction (path direction) from behind the tool.
Z Fin Allow	0	Additional finish allowance for the X and Z-axes.
X Fin Allow	0	
Clear	0.05	Clearance between start of groove profile and tool tip.
Lift Off	0.0025	Retract amount after each depth move.
Depth	0.1	Depth for incremental depth moves.
Stepover %	80	% of tool width to define distance of plunge steps.
Dwell	0.5	Dwell time at bottom of groove.
CSS Value	250	Constant surface speed (feed / minute).
Plunge Feed	0.0025	Plunge feed rate



If you apply any combination of “Z Fin/X Fin Allowance” to a groove cycle you have to create an additional Work Step to clean up the groove.

## CREATING TOOL PATH FOR WORK STEP #7

Before we continue there is one important thing to mention. Always specify a rapid move at begin and end of a curve if inside areas are machined. This causes the tool to start and retract from/to a safe position at begin and end of the machining operation. These moves will avoid crashes between tool and work piece. As the path for the tutorials groove cycle is located completely inside the part you will see rapid moves as the first and last curve element.

1. Select the “New” command from the “Curves” menu or click the corresponding button. In the dialog that opens type “Crv7-Groove” as the new ID and confirm with OK.



New



2. Select the “Rapid” command from the “Curves” menu to specify a rapid move as the first element of the new curve. Type “0.25” in the “Z” field and “2.0” in the “X” field of the Value Entry Box. Press ENTER to confirm the input of the first point. A small triangle is displayed on the screen.



Rapid

Then switch to the “Endpoint” pick mode from the “Edit/Point Picking” menu. Click the cursor on position #1 as shown in **Picture 4-18**. A dotted line representing the rapid curve move will be drawn on the screen.



Pick Endpoint

3. To continue with the groove profile select “Linear” from the “Curves” menu. The “Endpoint” pick mode is still activated. Click the cursor on positions #2 and #3 as shown in **Picture 4-18**.



Linear



Pick Endpoint

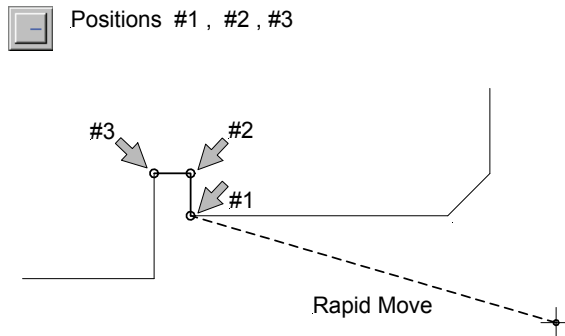

Picture 4-18

- Switch to the “Intersection of Two” pick mode from the “Edit/Point Picking” menu or use the corresponding button. The “Linear” curve command is still active.



Intersection  
of Two

Click the cursor on positions #4 and #5 as shown in **Picture 4-19** to select the two linear geometry elements. The system automatically snaps to the intersection of both elements and creates the last groove position.

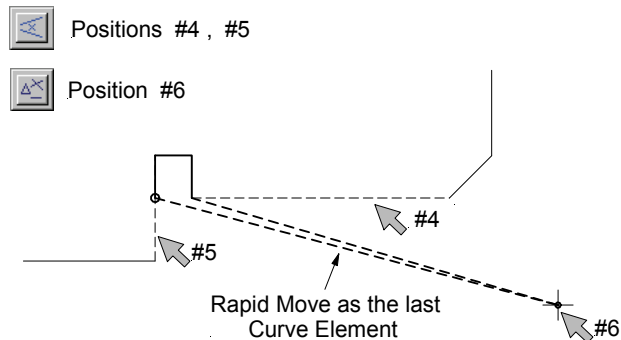

Picture 4-19

- For the last curve element select the “Rapid” command again. This move will specify the tool’s “retract” position at the end of the machining sequence. Switch to the “Snap All” pick mode and click at the position #6 as shown in **Picture 4-19**.



Rapid



Snap All

- To assign the new curve to the previously created Work Step click the “Path” status button and select the Curve ID “Crv7-Groove” from the Selection List Box.

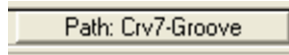

- Click the “Verify” button to calculate and display the tool path on the screen as shown in **Picture 4-20**.



Verify

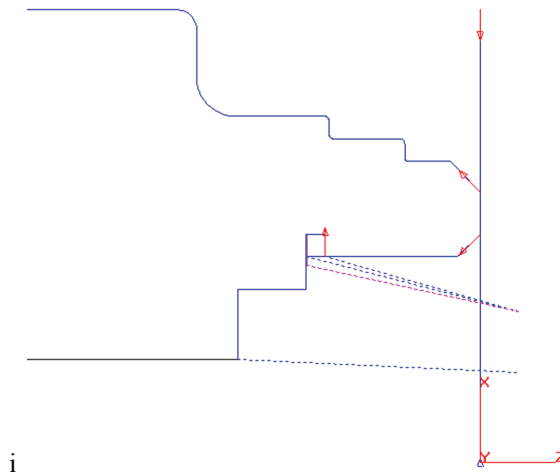

**Picture 4-20**

The Work Step #7 is now complete. Hit the “Redraw” button  to refresh the screen and remove the verified tool path display.



## CREATING WORK STEP #8 (THREADING CYCLE)

The threading cycle is the last machining cycle for the sample part. This cycle creates a standard UNC thread in the larger of the two bore diameters created earlier.

1. Click the Work Step Data button to open the “Work Step Data” dialog. Once it is open switch to the “Tool Info” tab.



2. Press the “New” button and input “8-Thread” as the new Work Step ID and confirm with OK.

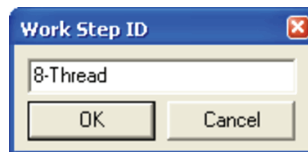

3. Select “Thread” from the cycle list. The path curve will be assigned later.

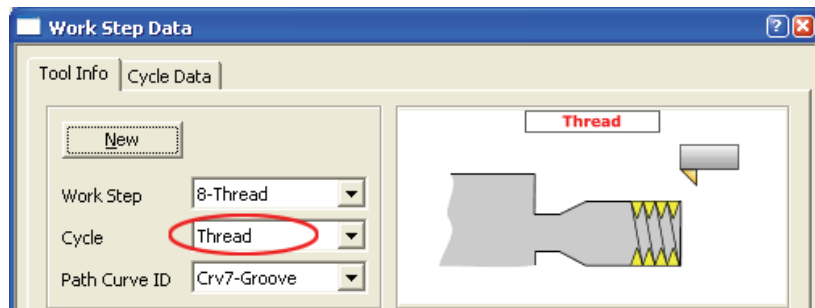

4. Click the “Select Tool” button from the “Tool Info” tab to open the “Select Tool” dialog box. Select “Thread” from the “Type” list box. Highlight the tool ID “651” (60 degree angle) from the list and click the “Select” button to load the tool.
5. On the “Tool Info” tab, change the settings as shown in the table below.

Dialog Field	Value	Comment
Number	7	Tool number on the tool turret / magazine.
Offset #	7	Tool's offset register number.

6. On the “Cycle Data” tab ensure that the parameters listed below are set correctly. Close the dialog using the “Close” button. See **Picture 4-21**

Dialog Field	Value	Comment
Steps	FIXED	Controls how thread passes/depth are defined. For 'Fixed' type, enter the “Total Steps” and “Depth” required for the threading operation. The decreasing depth increment for each pass is then calculated by the system in order keep a constant volume of removal.
Start Clear	0.25	Lead-In distance for thread passes.
End Clear	0.05	Specifies distance the tool feeds past the end of the thread before retracting (refers to the end point of the “Thread” path).
Withdraw Clear	0.05	Retract amount after each threading pass.
Engage Angle	-60	Specifies the engage angle of each pass. The value “-60” degree specified here will cause the tool to cut only on one side of the tool tip because the Z-axis start position of each pass is slightly shifted towards the work piece based on current depth increment and engage angle.
Withdraw Angle	90	Retract angle at end of threading passes
Z Lead	0.25	Sets the “tip to tip” lead along the Z-axis (lead from thread tip to thread tip, or “pitch”).
Depth	0.1325	Total depth of the thread
Total Steps	6	Sets the total number of steps required for the threading operation. This parameter is only applicable when “Fixed” has been selected in the “Steps” List Box.
Spring Passes	1	Number of spring passes at thread completion
Spindle RPM	700	Sets constant spindle RPM to 800 / minute
CSS Status	OFF	Set constant spindle RPM for threading.

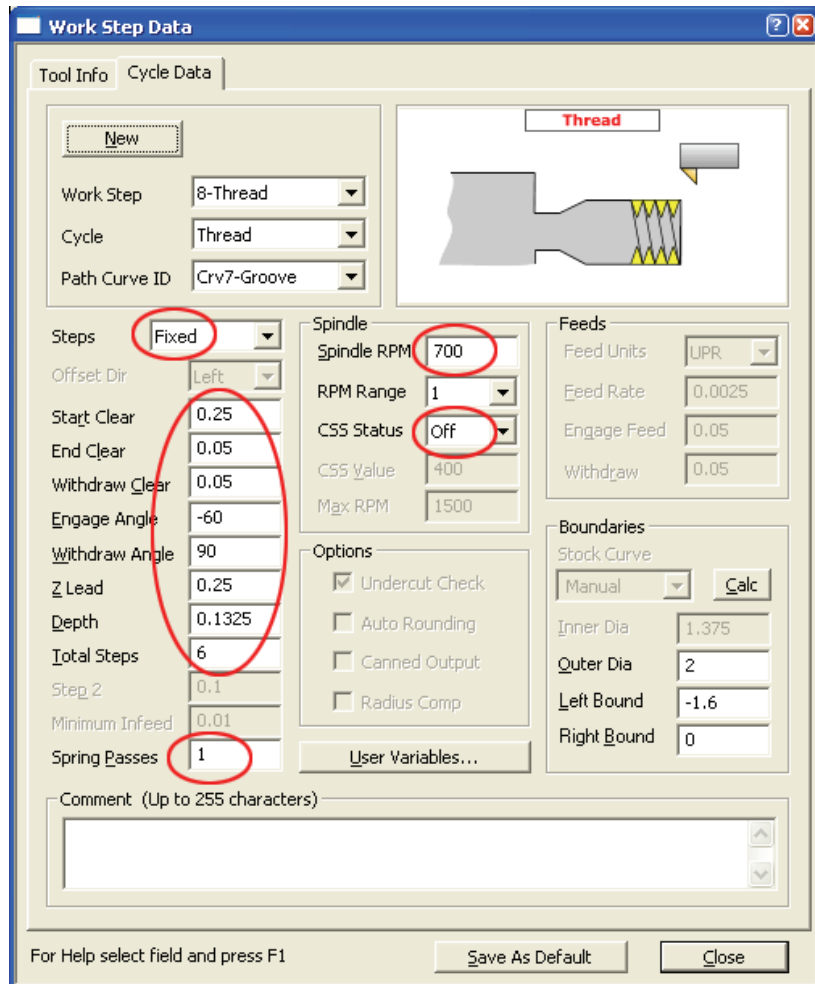

Picture 4-21

## CREATING TOOL PATH FOR WORK STEP #8

The threading path curve only requires a single linear move.

1. Select the “New” command from the “Curves” menu or click the corresponding button. In the dialog that opens type “Crv8-Thread” as the new ID and confirm with OK.



New

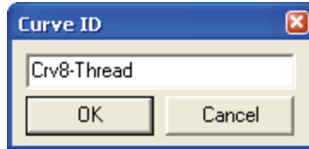

2. To create the path select “Linear” from the “Curve” menu, then switch to the “Endpoint” pick mode from the “Edit/Point Picking” menu. You may also use the corresponding toolbar buttons. Click the cursor on positions #1 and #2 as shown in **Picture 4-22**.



Linear



Pick Endpoint

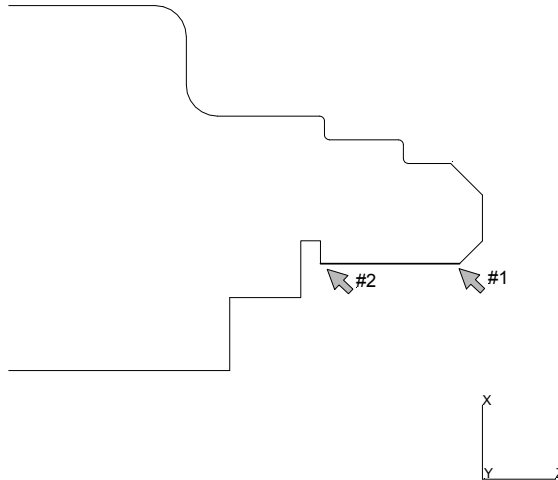

Picture 4-22

3. Finally select the “Rapid” command from the “Curves” menu. Type “0.25” in the “Z” field and “2” in the “X” field of the Value Entry Box. Press ENTER to confirm your input and the rapid element is appended to the curve.



Rapid

4. To assign the new curve to the previously created Work Step click the “Path” status button and select the Curve ID “Crv8-Thread” from the Selection List Box.

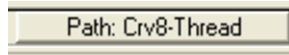

5. Click the “Verify” button to calculate and display the tool path on the screen as shown in **Picture 4-23**.



Verify

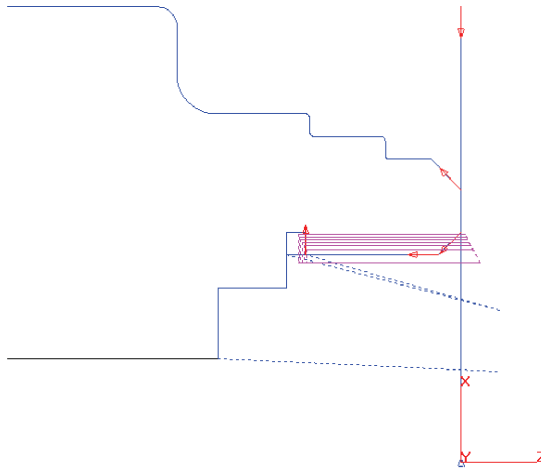

**Picture 4-23**

The Work Step #8 is now complete. Hit the “Redraw” button  to refresh the screen and remove the verified tool path display.

## VERIFYING ALL TOOL PATHS

In this tutorial, you have verified the tool path of each Work Step individually. The “Verify All” command in the “Post” menu is used to estimate the total time it will take to machine the part. It automatically performs an on-screen verification of all of the part program Work Steps in memory, in the machining order. The total machining time (excluding rapid traverse or tool change time) is displayed in a dialog box at the end of the verification process.



Verify All

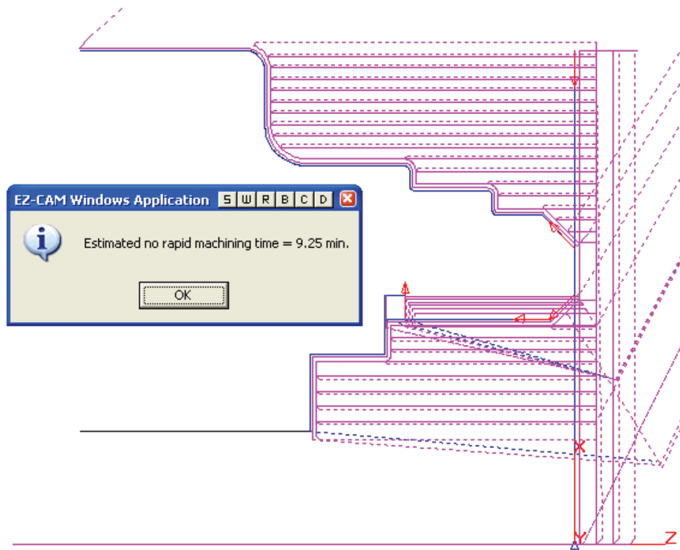

Picture 4-24

### 3D SOLID PREVIEW

One of the most powerful EZ-CAM features is the 3D solid preview function. This function shows an animated tool cutting a solid model of the programmed part. The stock size is automatically calculated according to the calculated tool movements. Once the simulation is finished or interrupted by the user pressing “Esc” key, all dynamic view commands to rotate, zoom or move the simulated model on the screen are available.

1. Select the “Preview 3D” command from the “Machining” menu or the corresponding button. See **Picture 4-25**.



Preview 3D



**Picture 4-25**

2. Once the simulation stopped you can change the on-screen view by using the dynamic view commands (Rotate, Pan, Zoom) under the “View / Dynamic Viewing” menu.



Dynamic Rotate



Dynamic Zoom



Dynamic Pan

## SAVING THE PART

It is very important to save the newly created or edited part from memory to disk periodically during a session as well as at the end to ensure that no information is lost. The EZ-CAM “Save” and “Save as” commands under the File menu transfer files from system memory to a hard disk or other media. In EZ-TURN, the part information is stored in two different types of files, the “Part” file using the extension "TRN" and the associated “Geometry” file with extension "GEO". This flexibility allows the user to load an existing part file to be used with newly created geometry and path curves.

File Type : **GEOMETRY**  
Extension : **GEO**  
Data : Geometry Elements (lines, arcs, etc.), Curves,  
User-Coordinate Systems (UCS)

File Type : **PART Files**  
Extension : **TRN**  
Data : Work Step Data (Technology & Machining Information)

There is no specific rule what should be saved first. Of course, if there is only one kind of data in memory (Work Steps or Geometry) the “Save as” dialog will automatically open with the correct file type.

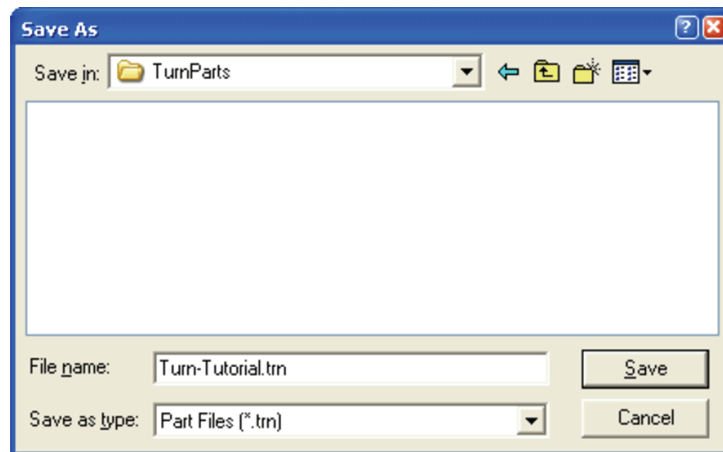

Picture 4-26



1. Select “Save as” command from the “File” menu.
2. Select the appropriate drive and folder where the geometry and part files should be stored. You can use the “EZCAMW \ TURNPARTS” folder that was automatically created by the setup routine.
3. Select “Geometry (\*.GEO)” from the “Save as type” list box to store the geometry data.
4. Type the new filename “Turn-Tutorial” in the File Name box and click the “Save” button. The file extension is added automatically.
5. To store the machining information (Work Step Data) select “Part Files (\*.TRN)” from the “Save as type” list box and click “Save” again.



If you have already saved the geometry, the software automatically inserts a part file with the same name but different extension (\*.3DP) in the “Save” menu when the first Work Step is created. All you have to do is to select “Save All” option from the “File” menu or the corresponding toolbar button.

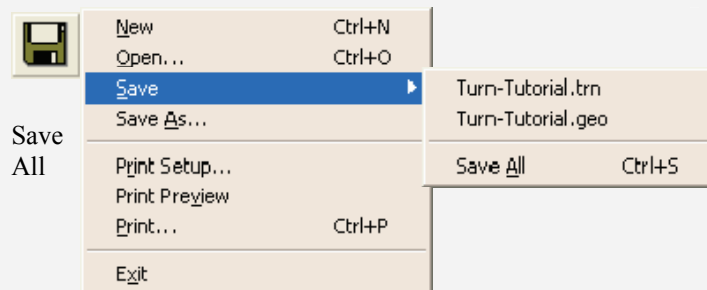

The software will save and overwrite the existing files without any screen prompt. You can use this command anytime for fast saving of your work.



It is not possible to save data when the software is running in evaluation mode. The “Save”, “Save as” and “Print” commands are disabled.

## CREATING CNC CODE

Now that the part program has been created, it must be converted to run on a NC control by running the “Post” command with the appropriate “Post-Processor” for your machine.



The CNC data file or “Post-Processor” is used as a "template" to format the part program data file that was created in EZ-Turn. This template consists of program formats (e.g., TOOL CHANGE, LINEAR MOVE, etc.) that determine the structure of a part program for a specific CNC. To create or edit a “Post-Processor” a special editor called “TBuild” is required.

1. Select “Post” command in the “Machining” menu to open the “Post Process” dialog.

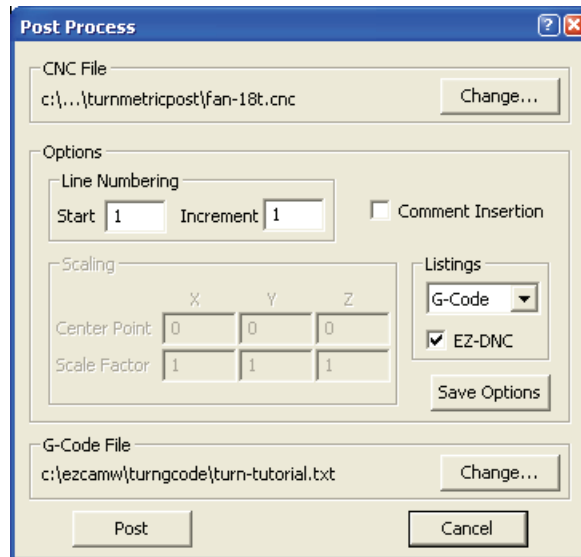

Picture 4-27

2. First you need to select the postprocessor. If the one desired is already loaded and displayed in the section “CNC-File”, continue to the next step. Otherwise use the “Change” button to browse your system for a different one. For this tutorial you may use the “FAN-18TI.CNC” post (standard inch post that creates Fanuc style code).



Standard postprocessor folders created by the EZ-CAM v15 setup:

INCH

<DRIVE>: \ EZCAMW \ EZCAM15 \TURNINCHPOST

METRIC

<DRIVE>: \ EZCAMW \ EZCAM15 \TURNMETRICPOST

3. Select the “G-Code” option from the “Listings” list box. The computed program text will be displayed on the screen.
4. Activate (check) the “EZ-DNC” option. This will automatically start the “EZ-DNC” application when posting of the part file is finished and load the newly created file for sending it to the machine using the serial port. See Chapter 6 “Communication with the Control” for more information about EZ-DNC.
5. Next is the “G-Code File” section. Here the default name and directory for the computed program file is displayed. The name is taken from the part file that was saved before. The default directory is “EZCAMW\TURNGCODE”.



Ensure that part file and postprocessor share the same dimension unit (“Inch” for this tutorial). The system will generate a “Dimension Unit Conflict” message, but then automatically scale the NC-Code according to the dimension specified in the postprocessor.

See online help for more information about the “Setup” dialog located in the “View” menu.

6. Click the “Post” to start posting. The Processing window will be displayed showing messages followed by listings of ASCII code created. When all Work Steps have been processed, a final message box is shown. See **Picture 4-28**.

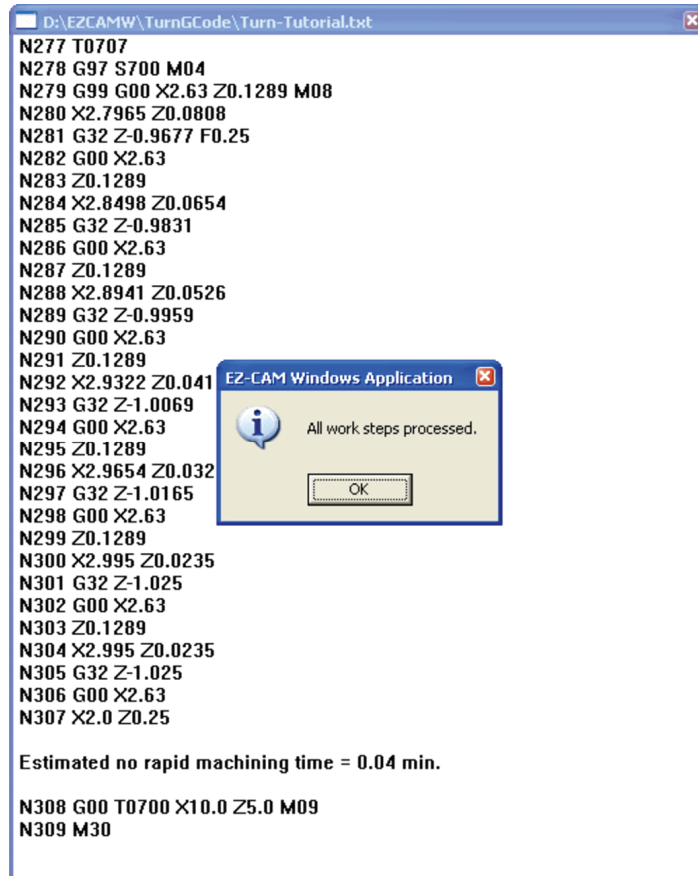

Picture 4-28

7. Click OK to close the message dialog box. To close the Processing window click  at the top right-hand corner of the window.

**Congratulations!**

**You've completed the EZ-TURN Tutorial !**

## CHAPTER 5.

# EZ-TURN / TURNMILL TUTORIAL

### OVERVIEW

This tutorial is intended for users with little, or no experience in EZ-TURN “Milling Operations”. The step-by-step instructions describe the complete process of creating the NC program for the part shown in **Picture 5-1** and **Picture 5-2**, focusing on the machining processes including C and Y-axis rotary tool operations (milling, drilling).

We will begin with regular turning operations to create the basic shape of the part. Then holes, slots and pockets on face and side of the part will be added by using the feature like turn-mill machining cycles of EZ-TURN.

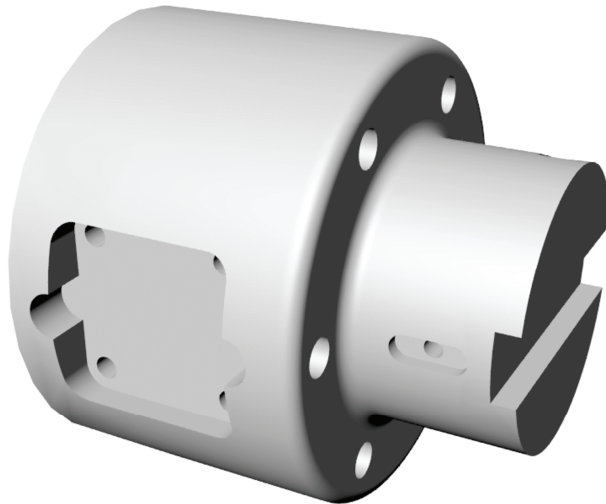

**Picture 5-1**

## BASIC PROGRAMMING STEPS

Before we continue with the tutorial let us explain the basic steps needed to create a part program with EZ-Turn.

### **STEP 1. Create Geometry**

Start by creating part geometry via commands under the Geometry Menu, using the coordinate system aids for appropriate positioning of the shapes on the SIDE and the FACE.

### **STEP 2. Create Work Steps and set Machining Parameters**

Define Work Steps for each machining operation and apply the parameters as required by type of operation and tool that is used. If needed, create and assign a path curve to each Work Step. Visualize the computed tool path to assure correct tool operation and proper setting of machining parameters.

### **STEP 3. Post G-Code**

Select the “Postprocessor” related to the type of control and let the software create the G-Code file.



The EZ-Turn / TurnMill Tutorial is set up in Metric with all Inputs and Dimensions in Millimeters !

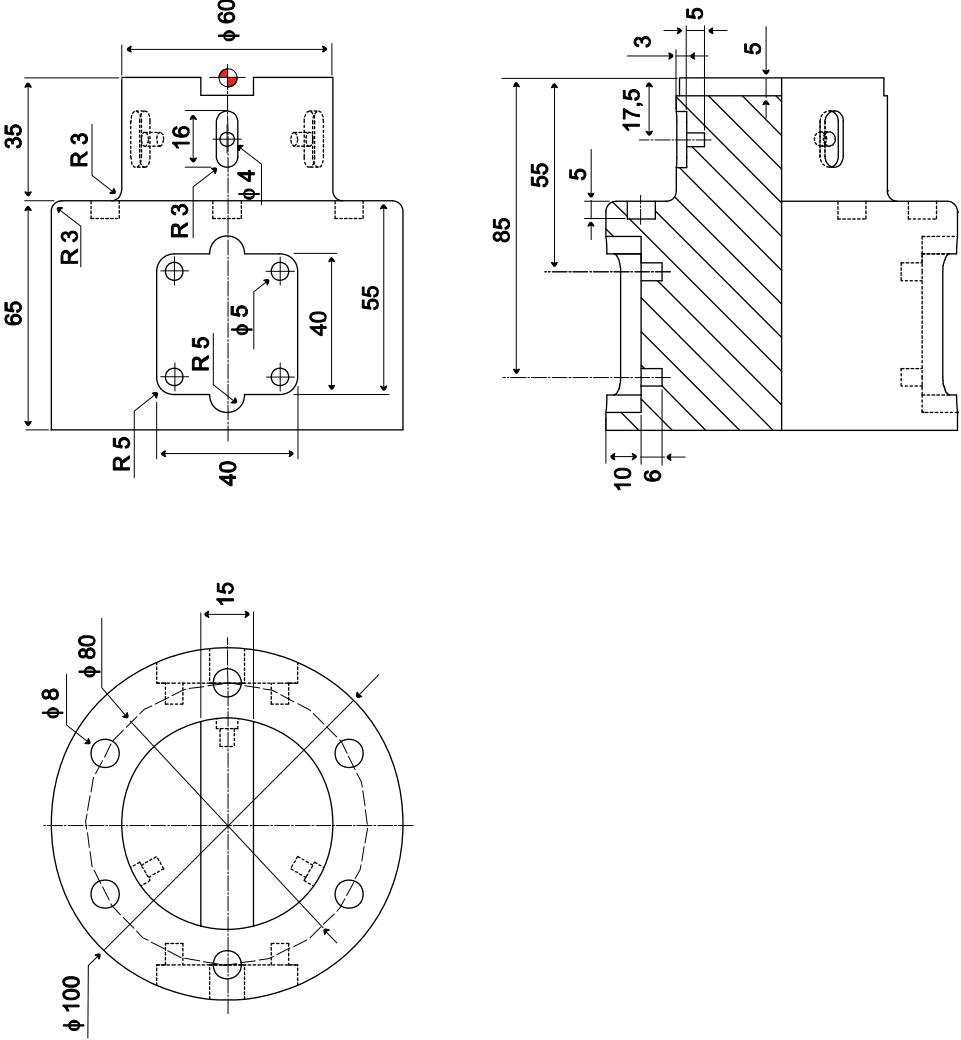

Picture 5-2

Blueprint of EZ-TURN / TurnMill Tutorial

## DEFINING ORIGIN, WINDOW SIZE AND LOCATION

The window size is the distance from the edge of the window to the center of the window. The window location is the signed, absolute position of the window center from the part's origin. The viewing parameters that are found in the Setup dialog box specify the size and location of the window. Note that you would not normally perform this step in programming a part, but it is necessary here to insure clarity in following the tutorial. Normally, you would just use the *Zoom/Fade* commands to set the window size as needed.

When selecting the origin for the part, choose a location that is referenced by the part's dimensions. The origin should be selected before defining the window location (see next topic for setting up the workspace), because the window center is referenced from the part's origin. The graphic in **Picture 5-3** below shows the location of the part origin for this exercise ( $X = -40$  ;  $Y = 0$ ).

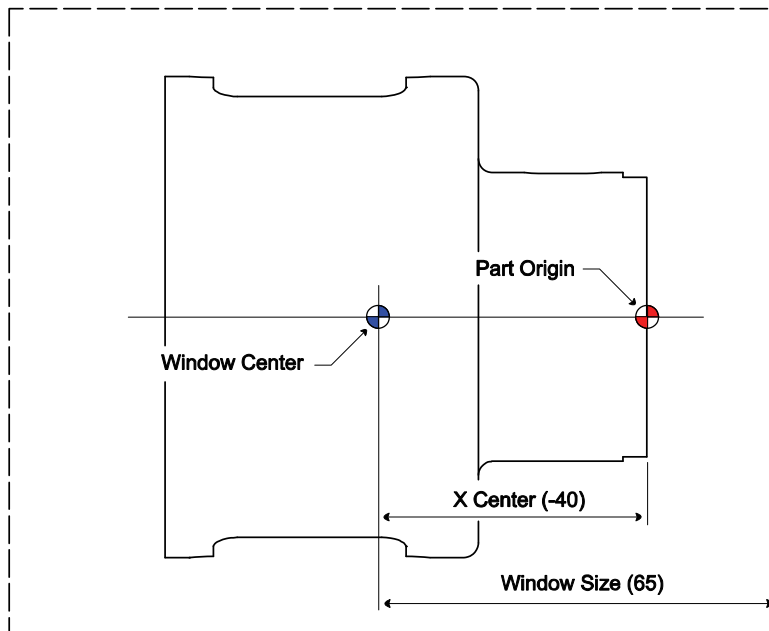

Picture 5-3



## SETTING PREFERENCES

Before continuing with the construction of the sample part, several parameters should be set so that the system is compatible with the instructions in this tutorial. Also the size of the workspace should be set. The sample part is about 100mm in the Z-axis and 100mm in the X-axis. Because of the size of the part, it is not convenient to work in the default window; therefore, the window and some default settings have to be changed.

1. Select "New" command from the "File" menu to restart EZ-CAM and clear the memory before continuing with the tutorial. Make sure that the "TURN" button is activated before pressing OK to start over.

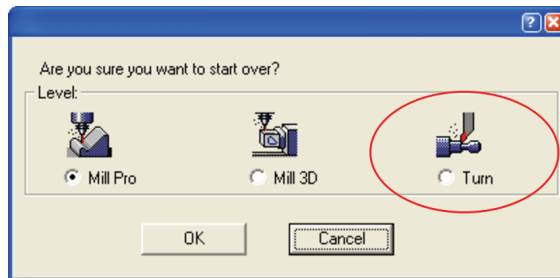

The "New" dialog is also used to switch between the EZ-Mill and EZ-Turn module. Before the dialog opens, the system checks the software protection key for activated modules. Modules or levels that are not activated will be marked by appended "DEMO" text. When working in "Demo" (evaluation) mode, it is not possible to print or save data. The corresponding "Save", "Save as" and "Print" commands are disabled.

When closing the EZCAM application, the system automatically stores the last used level as default for the next session.

2. Select "Setup" command from the "View" menu
3. Type "-40" for "X Center", "0" for "Y Center" and "65" for "Size". This sets the window size from the edge of the window to the center of the window, allowing enough room to see all of the part as it is created. See **Picture 5-4**.

4. Select “Metric” option button as the parts input dimension system.
5. Click the “Background” list box and select “Black”.
6. Select “Radius Input” option button as the parts X-axis input system.
7. Disable “Planar Chain” option.
8. Disable “Enable Y Coordinate Entry” option.
9. Enable “Blank Verify”, “Show Curve Direction” and “Save as Default” options. Then close the dialog with OK button.

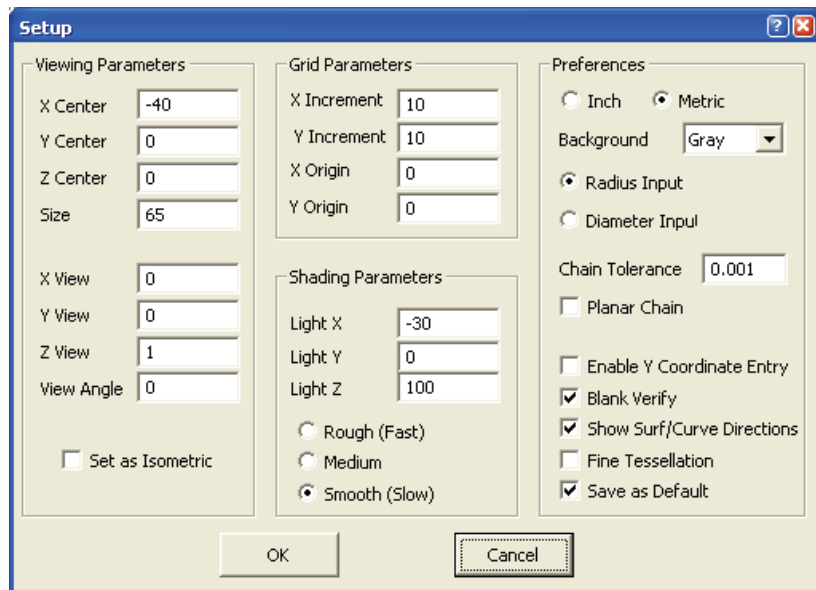

**Picture 5-4**

The initial setup for the EZ-TURN / TurnMill tutorial is now complete. Continue with the next section to create the geometry necessary for this part.

### CREATING PART GEOMETRY (TURNING)

Now that the workspace has been adjusted to accommodate the part, the creation of the part can begin. This involves creating geometry that is used to define the path curves for machining the part. The geometry is created first, so that the process of creating the curves is greatly simplified.

First, we will define the basic geometry that defines the outside contour of the sample part. Then we continue with inserting the various fillets. At any time you may use the Undo/Redo buttons in the upper left corner to correct any mistakes you make.

- 1. Select the “Connected Lines” command from the “Geometry” menu or click the corresponding button on the toolbar.



Connected Lines

- 2. EZ-TURN prompts you to pick the first point. Type “0” in the “Z” field of the Value Entry Box. Then press Tab to move the focus to the “X” input field. Type “0” for the X location and press the ENTER button to confirm the first point.

	Z	X
P1	0	0

- 3. Continue entering the Z and X values for points #2 to #5 as listed in the table below. Press ENTER for each point to confirm the Z and X input. When finished the part geometry should appear as in **Picture 5-5**.

	Z	X
P2	0	30
P3	-35	30
P4	-35	50
P5	-100	50

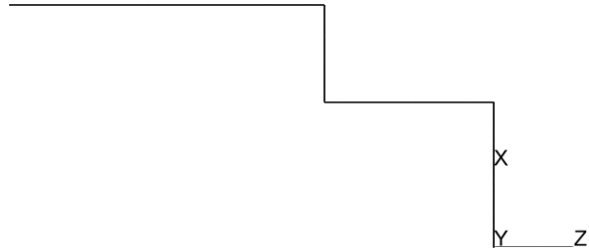
**Picture 5-5**

### CREATING GEOMETRY FILLETS (TURNING)

Follow the instructions below to create corner fillets for the main profile geometry of the sample part.

1. Select the “Corner Fillet” command from the “Geometry” menu or click the corresponding button on the toolbar.

**Corner Fillet**

2. Type “3” in the “R” field of the Value Entry Box to set the radius for the corner fillet. Then click the cursor at each position as shown in **Picture 5-6**.

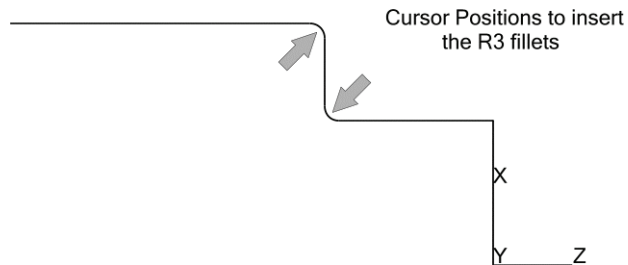
**Picture 5-6**

## CREATING PATH CURVES (TURNING)

EZ-Turn uses the curve entity to define a cutter path for each machining Work Step. Therefore we will now create the curves that are later used to define the path for the facing and outside turning operations before we continue to define geometry and curves for the turn-mill operations. The first curve will be used for facing while the second one represents the outside turning profile.

1. Select the “New” command from the “Curves” menu or click the corresponding button. In the dialog that opens type “Crv1-Face” as the new ID and confirm with OK (Crv1 is the systems default ID and FACE is simply a description of the purpose of the curve).



New

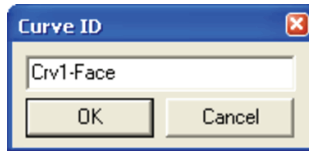

2. Select the “Linear” command from the “Curves” menu or click



Linear

3. The curve for this Work Step will consist of only one single linear move. To define the first point type “0” in the “Z” field of the Value Entry Box. Press Tab to move the focus to the “X” input field. Type “52.5” for the X location and press the ENTER button to confirm the first point. A small triangle is displayed on the screen.
4. For the second point type “0” for the X location (“Z” is already “0”) and press the ENTER button to confirm the second point. A blue line representing the new curve is now visible on the screen as seen in **Picture 5-7**

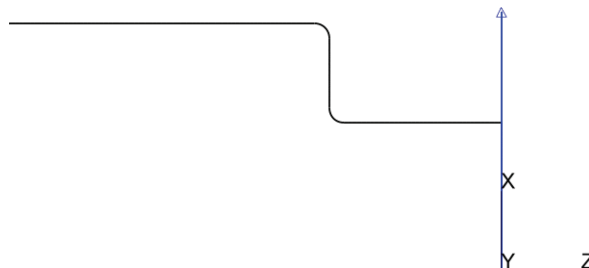

**Picture 5-7**

Now, let's create the second curve that represents the outside turning profile.

1. Select the “New” command from the “Curves” menu or click the corresponding button. In the dialog that opens type “Crv2-Turn” as the new ID and confirm with OK.



New

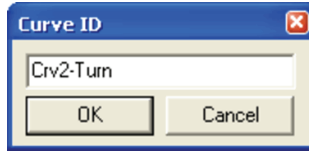

2. Select the “Chain” command from the “Curves” menu or click the corresponding button.



Chain

3. The prompt “Pick first line, arc, circle, or point figure” is displayed at the bottom edge of the window. Move the cursor to the position shown in **Picture 5-8** and double-click the mouse to select the line as the first element in the curve chain. The software automatically completes the curve by following the connected geometry elements from the first point to the last. A small arrow referred to as the “direction indicator” visualizes the curve direction.

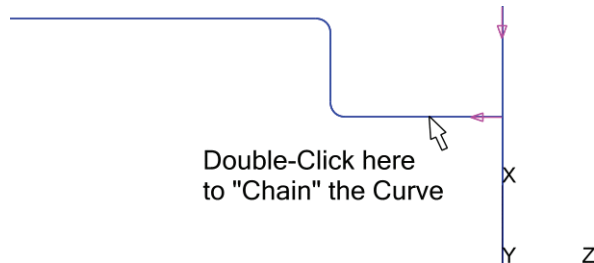

**Picture 5-8**



In case path chaining failed for some reason (selected wrong element or position), simply delete any already existing path elements by using the “Delete All Links” command from “Curves” menu. Then select “Chain” command and try again.

## CREATING PART GEOMETRY (SIDE-POCKET)

In the previous steps we created geometry and path curves for the regular turning operations. Next step will be doing the same for the pocket profile on the side of the part that will later be machined in a milling operation. All other turn-mill operations to machine the holes, small slots and the bolt-hole circle do not require any geometry or path curves since EZ-TURN provides machining cycles that include automatic pattern creation functions.

Before we continue with creating the geometry for the pocket we need to select the "SIDE" coordinate system in order to place the geometry correctly.

1. Click the "Current UCS" button on the left bottom side of the window.

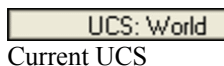

2. Click "SIDE" from the "Selection List Box" to change the coordinate system.



3. Select "View X-Z" from the submenu "View Control" located in the "View" menu or press the corresponding button on the toolbar.

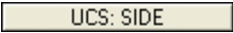

View X-Z

The steps 1-3 mentioned above are needed to prepare the working plane for SIDE geometry creation. Please check the "Current UCS" status before starting to draw the geometry. It should display  and the coordinate axes on the working plane should be X and Z. EZ-CAM window should now look like shown in **Picture 5-9**. What looks like a line in this picture is actually the previously created turning geometry as viewed from top. This is because the "SIDE" coordinate system is perpendicular to the "WORLD" coordinate system (see **Picture 5-10**).



**Picture 5-9**

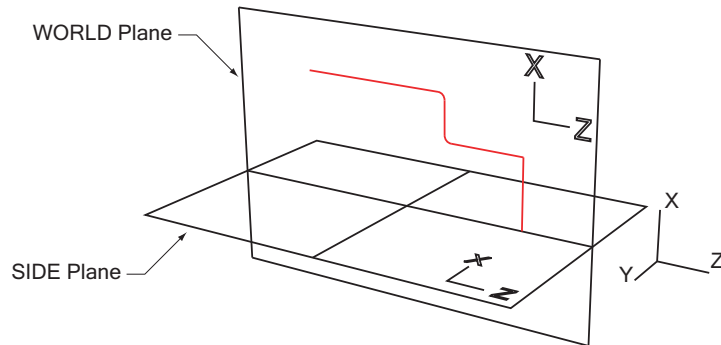

**Picture 5-10**

As we switched to the SIDE-working plane, there is no difference for applying any geometry to the current coordinate system. As you may have noticed at the **Picture 5-10**, the Z-axis for the SIDE plane coincides with the machine Z-axis. However, It is important to note that in EZ-TURN, geometry is always created on the XZ plane of the current coordinate system no matter if it's later used for turning or milling operations. Movements defined on the X-axis of the SIDE coordinate system will later be interpreted as Y axis moves or wrapped profiles around Z axis (if no Y axis available). Coordinate and axis designator conversions are handled automatically by the system when posting the NC code.

Let's continue with the drawing of the rounded rectangle shape for the pocket boundary on the side of the part.

1. Select the "Rectangle, Corner to Corner" command from the "Geometry" menu or click the corresponding button on the toolbar.



Rectangle, Corner to Corner

2. EZ-TURN prompts you to pick the first point. Type "-90" in the "Z" field of the Value Entry Box. Then press Tab to move the focus to the "X" input field. Type "-20" for the X location and press the ENTER button to confirm the lower left corner point of the rectangle.



3. EZ-TURN prompts you to pick the second point. Type “-50” in the “Z” field of the Value Entry Box. Then press Tab to move the focus to the “X” input field. Type “20” for the X location and after another Tab keystroke input “5” for the radius value of the rectangle edges. Finally press the ENTER button to confirm the other corner location and edge roundness of the rectangle.

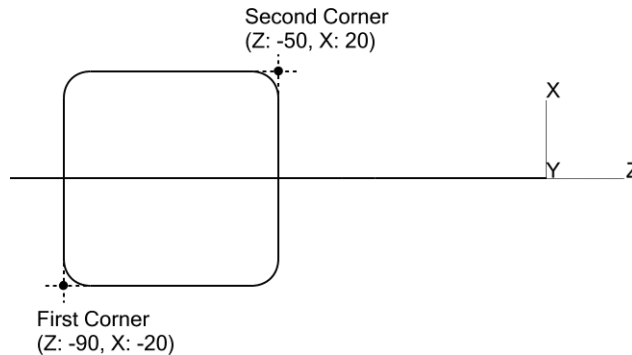

**Picture 5-11**

After creating the pocket boundary rectangle with round corners, the half circles at the two sides will be appended to the contour. This will be done by drawing circles centered at the middle points of the left and right side lines and trimming unnecessary segments from the shape afterwards.

1. Select the “Circle/Arc, Center, Radius” command from the “Geometry” menu or click the corresponding button on the toolbar.



Circle/Arc, Center, Radius

2. The radius input field of the Value Entry Box becomes active and selected. Type “5” in the “R” field to designate the circle radius.

3. Turn on the “Midpoint” snap mode from the "Edit / Point Picking" menu or simply press the corresponding button on the toolbar.



Midpoint

4. EZ-TURN prompts you to pick the center point of the circle. Click the two points near the side lines of the rounded rectangle as shown in the **Picture 5-12**. This will draw two circles centered at the middle points of the rectangle sides.

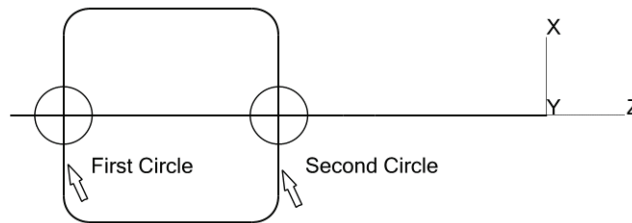
**Picture 5-12**

Now, let's trim the half of the circles and the line segments inside the circles to obtain the outer contour of the pocket.

1. Select the “Remove to Closest” command from the "Geometry / Edit Line, Arc or Circle" menu or click the corresponding button on the toolbar.



Remove to Closest

2. Click near the objects to be trimmed as shown in the **Picture 5-13**. Before clicking, check for the highlighted geometry sections (dashed lines in the picture) to verify removing the correct segment.

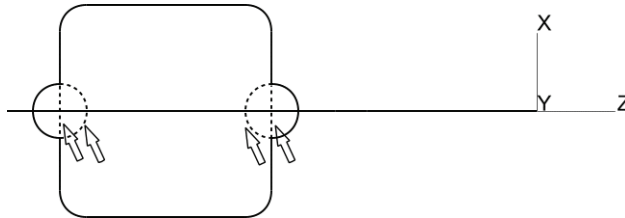

**Picture 5-13**

After removing the unnecessary sections from the part's side pocket profile, you will draw the connected lines to define the drilling locations in the pocket boundaries. The joints of the connected lines represent the center locations for the drilling operation.

1. Select the "Connected Lines" command from the "Geometry" menu or click the corresponding button on the toolbar.



Connected Lines

2. Turn on the "Center Arc/Circle" snap function from the "Edit / Point Picking" menu or simply press the corresponding button on the toolbar.



Center Arc/Circle

3. Click the points defined in the **Picture 5-14**, sequentially from point #1 to point #4.

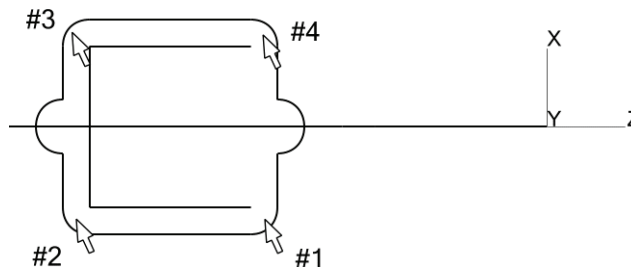

**Picture 5-14**

## CREATING PATH CURVES (SIDE POCKET)

Now we will create two more path curves. The first defines the pocket boundary while the second one represents the center locations for the drilling operations, all on the side of the part.

1. Select the “New” command from the “Curves” menu or click the corresponding button. In the dialog that opens type “Crv3-Pocket” as the new ID and confirm with OK (Crv3 is the systems default ID and POCKET is simply a description of the purpose of the curve).



New

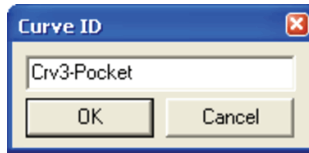

2. Select the “Chain” command from the “Curves” menu or click the corresponding button.



Chain

3. The prompt “Pick first line, arc, circle, or point figure” is displayed at the bottom edge of the window. Move the cursor to the position shown in **Picture 5-15** and double-click the mouse. The software automatically completes the curve by following the connected geometry elements from the first point to the last. A small arrow referred to as the “direction indicator” visualizes the curve direction.

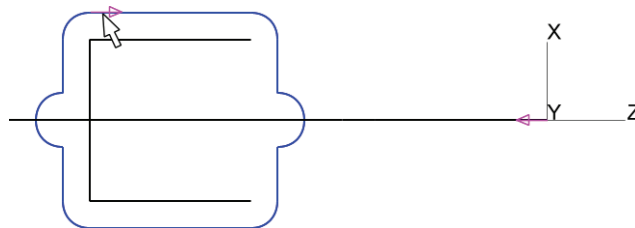

**Picture 5-15**



Please note that, “Planar Chain” option in the “Setup” dialog box should be “unchecked” in order to successfully apply chain operation for the geometry elements when you are working on the SIDE coordinate plane.

Now, let’s create the curve needed to represent the hole centers for the drilling operation on the side.

1. Select the “New” command from the “Curves” menu or click the corresponding button. In the dialog that opens type “CrvSideDrill” as the new ID and confirm with OK.



New

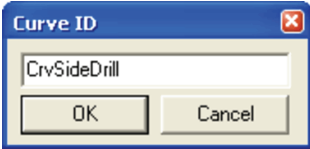

2. Select the “Chain” command from the “Curves” menu or click the corresponding button.



Chain

3. The prompt “Pick first line, arc, circle, or point figure” is displayed at the bottom edge of the window. Move the cursor to the position shown in **Picture 5-16** and double-click the mouse to select the line as the first element in the curve chain. The software automatically completes the curve by following the connected geometry elements from the first point to the last. A small arrow referred to as the “direction indicator” visualizes the curve direction.

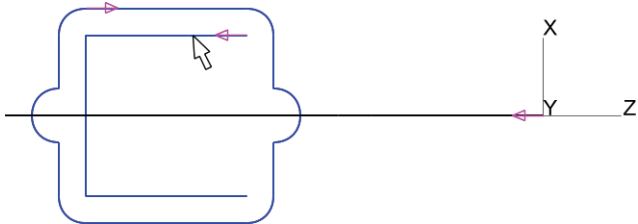

Picture 5-16

## CREATING THE PART PROGRAM

Now as the geometry and some of the path curves (some feature-based Work Steps automatically create needed curves, so we do not have to draw them) for the tutorial is completed, we continue with creation of the Work Steps necessary to machine the part. For this, select the desired cycle (Profile, Turn, Bore, etc.) for the regular turning operations or the feature to be applied for the milling / drilling operations. Then specify associated tool settings and machining parameters and define the path representing the cutting border (location for drilling). Finally verifying the calculated tool path assures correct tool operation. When all necessary Work Steps have been defined, the complete part program can again be verified for visual checks. If everything is ok continue to the next step and create the CNC-Code.

### **The part program of the tutorial will consist of these 8 Work Steps:**

1. Face the front surface.
2. Turn the exterior profile.
3. Milling two pockets on the side of the part using Y -axis.
4. Drilling four holes at the base of these two pockets.
5. Milling three longitudinal side-slots equally spaced on the circumference.
6. Drilling a hole at the center of each side-slot.
7. Drilling 6 holes of the bolt-hole circle on the face of the part.
8. Milling a rectangular slot on the front face.



Execution of the Work Steps will be in the same order they have been created. You can use the integrated spreadsheet to perform operations such as moving, reordering or deleting existing Work Steps.

See the “Spreadsheet” book in the online help for more detailed information.

## CREATING WORK STEP #1 (FACE TURNING)

Now we create the first work step selecting a profile cycle that will make two passes on the face to make it an even surface. The two passes are defined by the "Total Stock" and "Depth" settings on the "Cycle Data" tab of the Work Step Data dialog.

1. Select the "Work Step Data" command in the "Machining" menu to open the "Work Step Data" dialog. Once it is open switch to the "Tool Info" tab.

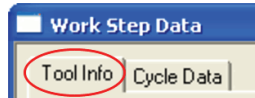

2. Press the "New" button and input "Trn-Face" as the new Work Step ID and confirm with OK.



3. Select "Profile" from the cycle list and "Crv1-Face" as the path curve.

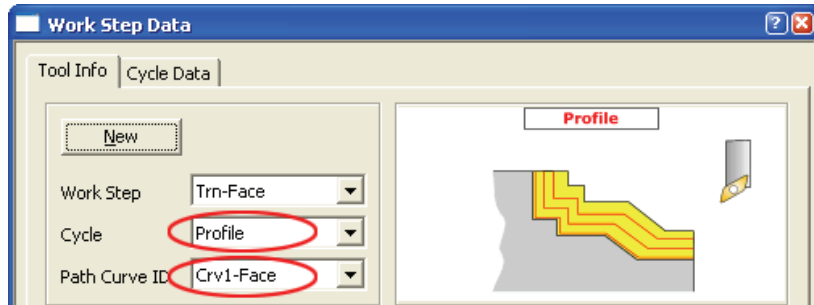

4. Now we select a tool. For this click the "Select Tool" button from the "Tool Info" tab to open the "Select Tool" dialog box. If there are no tools available select the "Change" button to load the "METTOOL.TLS" database from the "EZCAMW \ EZCAM.." directory. "EZCAM.." stands for the directory of the currently installed software release (\EZCAM14\.). This tool library includes the tools needed for the tutorial.

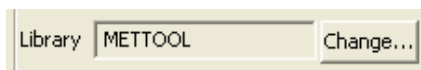

Once the database is loaded highlight the tool ID “4-R08-80” (80 degree diamond insert, tip radius 0.8) and click the “Select” button as shown in **Picture 5-17**.

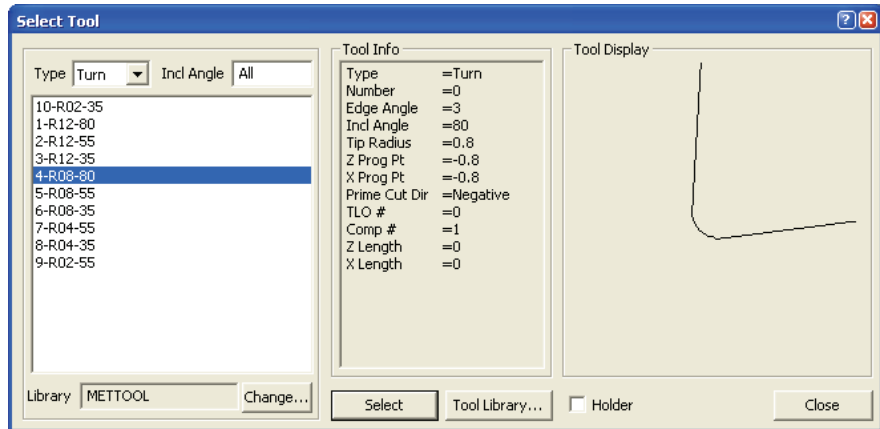

**Picture 5-17**

- As we are already on the “Tool Info” tab, change the dialog settings as shown in the table below. See **Picture 5-18** for the full dialog.

Dialog Field	Value	Comment
Number	1	This number represents the tool position on the tool turret / magazine.
Offset #	1	Specifies the register number on the control were the current tool's offset compensation values are stored.
Z Index	125	Tool change position for Z axis
X Index	125	Tool change position for X-axis
Coolant	FLOOD	



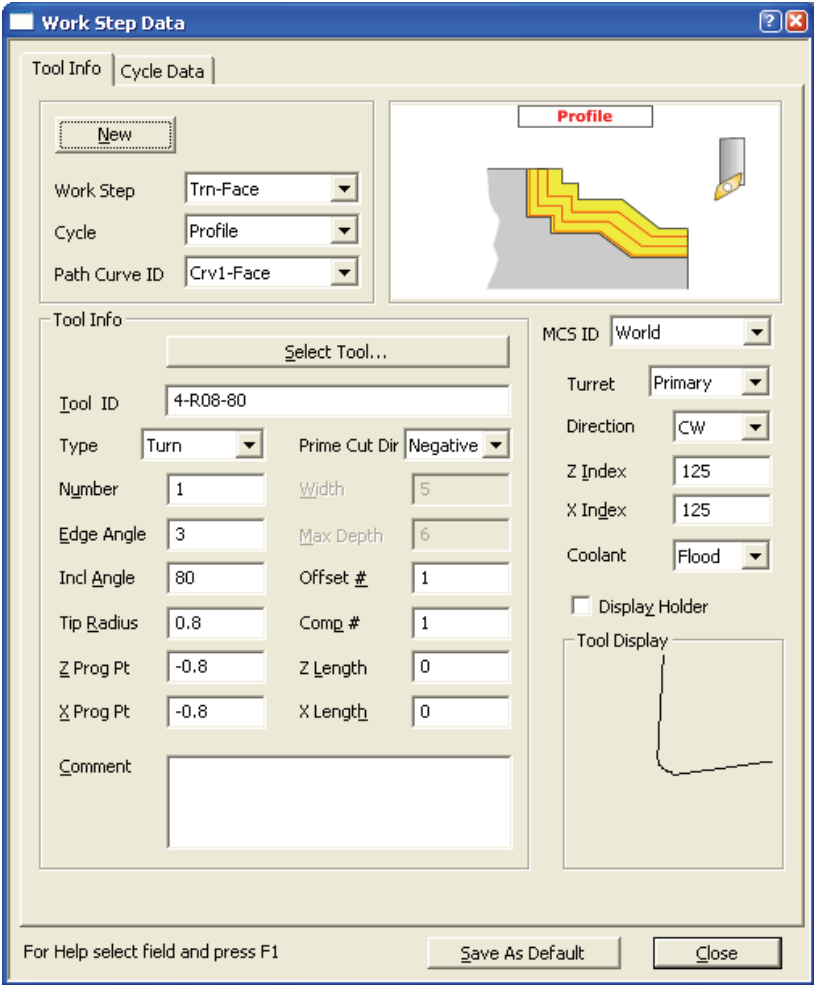

Picture 5-18

6. Now select the “**Cycle Data**” tab and change settings according to the table below. Then close the dialog using the “Close” button. See **Picture 5-19**.

Dialog Field	Value	Comment
Offset Dir	Left	Defines the toolpath side as to the related curve and its direction.
Z Fin Allow	0	Finish allowance for the X / Z-axes.
X Fin Allow	0	
Clear	2.5	Clearance distance between material boundary and tool tip at the start of the cycle.
Engage Angle	90	Angle applied to engage move at the beginning of each roughing pass.
Withdraw Angle	90	Angle applied to retract move at the end of each roughing pass.
Depth	1	Incremental depth increment for each pass.
Total Stock	2	Total amount of stock to be machined.
CSS Status	ON	When constant surface speed is set to ON, the machine tool automatically adjusts the RPM to maintain the specified CSS value.
CSS Value	90	Sets constant surface speed (feed / minute).
Max RPM	5000	Sets maximum spindle RPM if CSS ON.
Feed Units	UPR	Sets Feed Rate type to <b>Units Per Revolution</b> .
Feed Rate	0.25	Machining feed rate
Outer Dia	105	Outside stock diameter
Left Bound	0	Absolute Z position for left stock boundary
Right Bound	2	Absolute Z position for right stock boundary

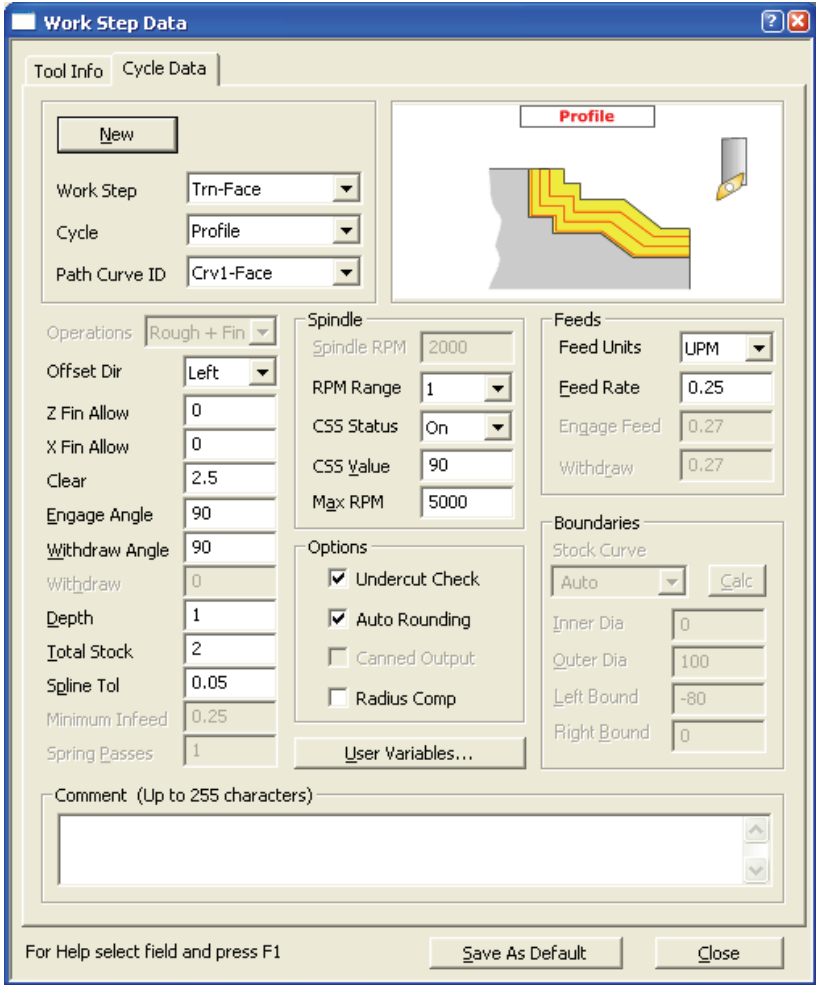

Picture 5-19

- In order to correctly visualize the toolpath verification, first change the view. For this, press the “Current UCS” button on the left bottom side of the window. Click “World” from the “Selection List Box” to change the coordinate system. Select “View X-Z” from the submenu “View Control” located in the “View” menu or press the corresponding button on the toolbar.

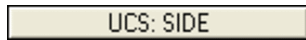

Current UCS



View X-Z

- Click the “Verify” button to calculate and display the tool path on the screen as shown in **Picture 5-20**.



Verify

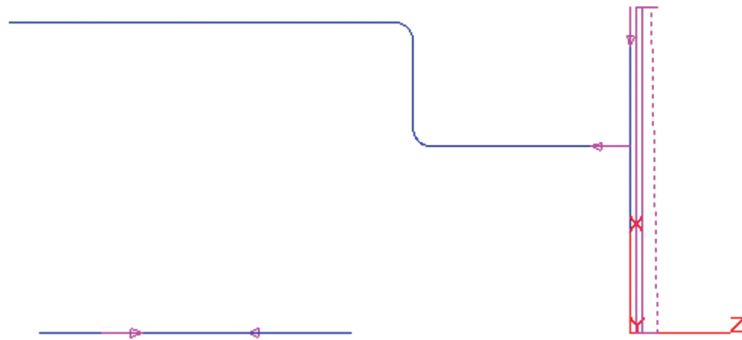

**Picture 5-20**

The Work Step #1 is now complete. Hit the “Redraw” button  to refresh the screen and remove the verified tool path display.

## CREATING WORK STEP #2 (OUTSIDE TURNING)

The next step in creating the part program is to set up the turning cycle that turns down the exterior surfaces.

1. Select the “Work Step Data” command in the “Machining” menu to open the “Work Step Data” dialog. Once it is open switch to the “Tool Info” tab.
2. Press the “New” button and input “Trn-OD-Rough” as the new Work Step ID and confirm with OK.

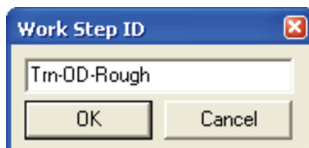

3. Select “Turn” from the cycle list and “Crv2-Turn” as the path curve.

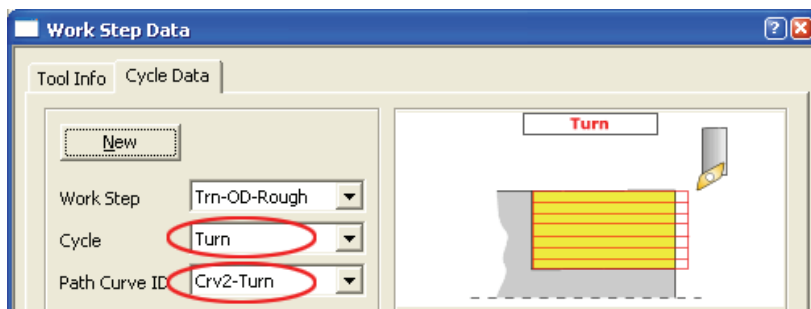

4. Ensure that all parameters on the “Cycle Data” tab are set as listed in the table below. Other settings (also on “Tool Info” tab) are identical to the previous Work Step. Close the dialog using the “Close” button. See **Picture 5-21**

Dialog Field	Value	Comment
Z Fin Allow	0	The “Fin Allow” settings specify separate finish allowance values for the X and Z axes
X Fin Allow	0	
Clear	2.5	Clearance distance between the material boundary and the tool tip at the start of the cycle.
Withdraw Angle	45	Angle applied to retract move at the end of each roughing pass.

Withdraw Length	1.25	Length of move when retracting at the end of each roughing pass.
Depth	2	Depth increment for each pass of roughing routine.
Feed Rate	0.25	Feedrate rough passes
Engage Feed	0.25	Feedrate depth moves
Withdraw Feed	0.25	Feedrate retract moves
Outer Dia	105	Outside stock diameter
Left Bound	-100	Absolute Z position for left stock boundary
Right Bound	0	Absolute Z position for right stock boundary

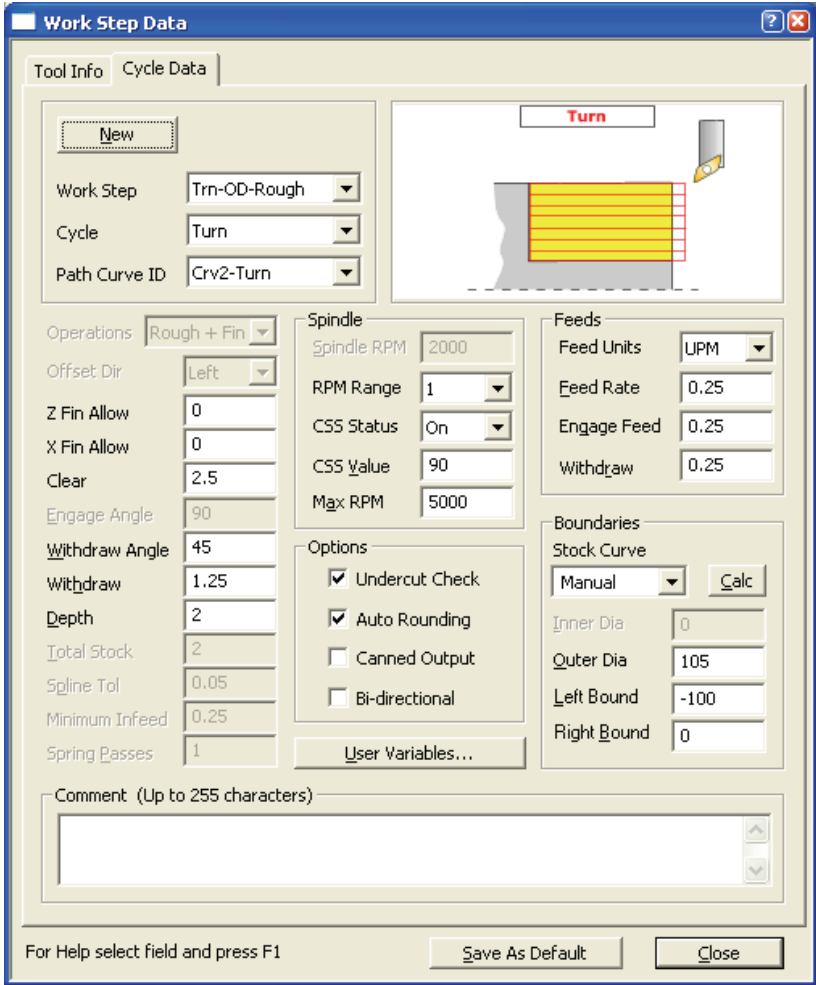

Picture 5-21

5. Click the “Verify” button to calculate and display the tool path on the screen as shown in **Picture 5-22**.



Verify

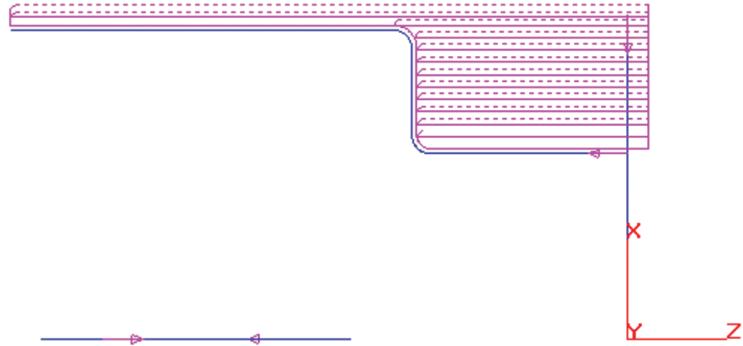

**Picture 5-22**

The Work Step #2 is now complete. Hit the “Redraw” button  to refresh the screen and remove the verified tool path display.



### CREATING WORK STEP #3 (POCKET MILLING)

This work step uses the "Turn Milling (Curves)" feature with its "Pocket (Standard)" cycle to remove the material inside the defined boundary path curve. Finally the tool path will be copied 180 degree's to the opposite of the part using the parameters available on the "Copy & Indexing" dialog.

1. Select the "New\_Curve\_Milling" command from the "Automation" menu or click the corresponding button. In the dialog that opens type "Side-Pocket" as the new ID and confirm with OK.



New Curve Milling

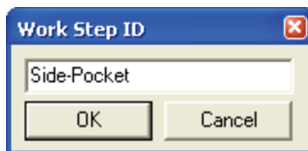

2. Ensure that all parameters on the dialog are set as listed in the table below. When finished, the dialog should be displayed as shown in **Picture 5-23**.

Dialog Field	Value	Comment
Tool Number	2	Tool number on the tool turret / magazine.
Offset #	2	Tool's offset register number.
Diameter	8	Diameter of the milling tool.
Coolant	FLOOD	
Spindle RPM	1200	Rotation speed of the milling tool.
Feedrate (Z)	75	Plunge feedrate.
Feedrate (XY)	150	Planar cutting feedrate.
Surf (Zs)	50	Radial position of the cutting path's starting point.

Rapid	2	This parameter sets the main reference plane of the plunge axis as an absolute value from current MCS ("SIDE") . All other depth and rapid move settings (Rapid, Clear, Depth) are defined in relation to this plane.
Clear	2	This parameter sets the distance at which all rapid XY moves occur above the part. It is an unsigned incremental distance above the "Surf (Zs)"parameter.
Depth (Zd)	10	This parameter sets how far below the "Surf (Zs) parameter the tool will cut. The tool makes passes at the Step increment until it reaches the Depth level below the Surface level.
Step	2	Depth of each cutting pass.
Location	Side	Working plane that has the cutting path on.
MSC ID	SIDE	<b>M</b> achining <b>C</b> oordinate <b>S</b> ystem that is used.
Cycle	Pocket (Standard)	Cutting Method that will be used for this step.
Curve ID	Crv3-Pocket	Path curve to be machined.
Cut Step	4	Step-over distance.
Y Axis Output	ON	Spindle will be locked and Y-axis will be used for movements. If unchecked, the tool path will be wrapped around the Z axis

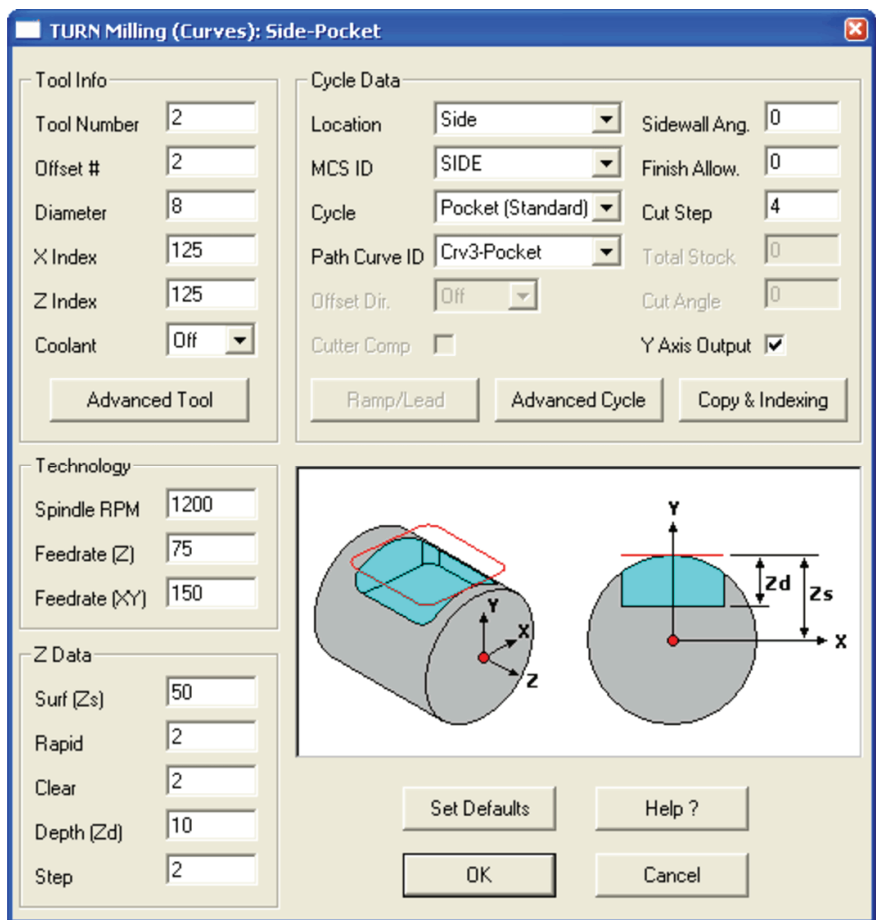

Picture 5-23

3. Click the “Copy & Indexing” button in the “TURN Milling (Curves)” window to open the “Side Copy & Indexing Options” dialog box and change the “Index Copy” settings according to the table below (see **Picture 5-24**). Confirm the settings by pressing “OK” button. After closing “Copy & Indexing” options, also confirm and close the “TURN Milling (Curves)” window by pressing its “OK” button.

Dialog Field	Value	Comment
Start Angle	0	Designates the radial start angle of the toolpath.
Increment Angle	180	Angle between each copied toolpath.
Copies #	2	Total number of toolpath copies that will be duplicated around the part.

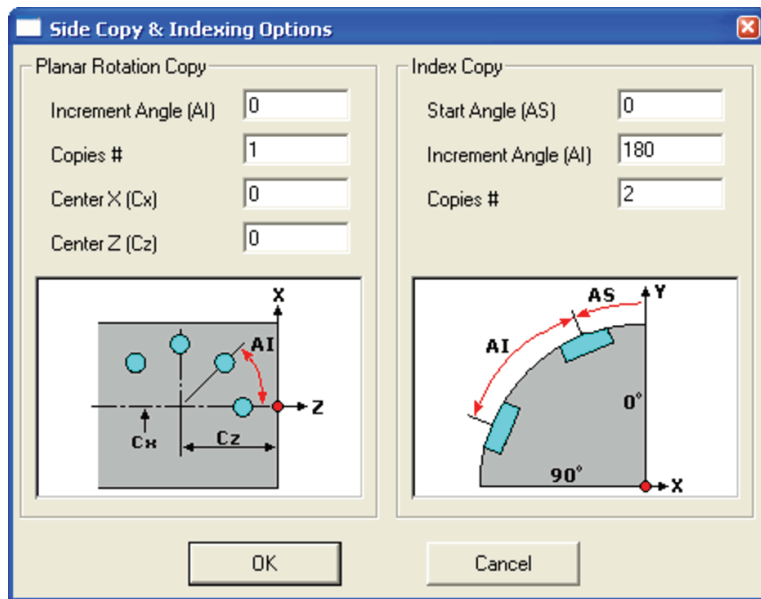

Picture 5-24

- Click the “View Isometric” button and prepare an angular view.



View Iso-  
metric

- Click the “Verify” button to calculate and display the tool path on the screen as shown in **Picture 5-25**.



Verify

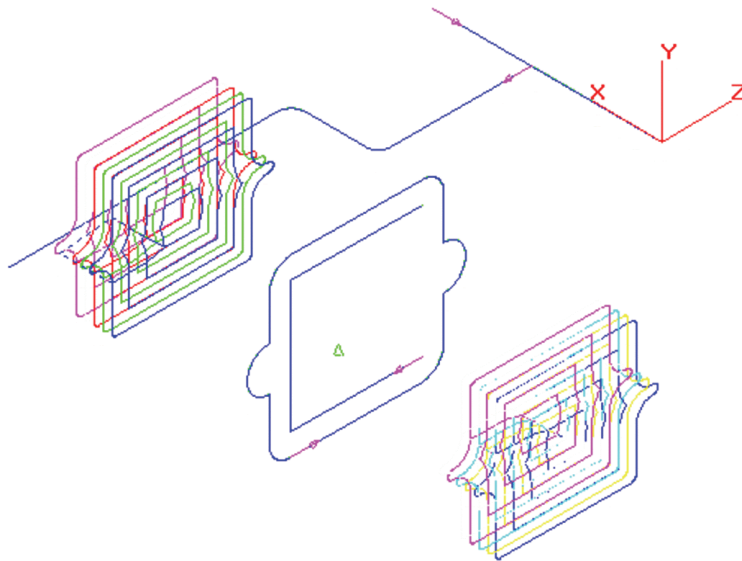

**Picture 5-25**

The Work Step #3 is now complete. Hit the “Redraw” button  to refresh the screen and remove the verified tool path display.

## CREATING WORK STEP #4 (SIDE DRILLING)

The purpose of this work step is to drill the four holes at the bottom of the two pockets that were created previously. The tool path will again be copied 180 degree's for machining the holes in the second pocket.

1. Select the “New\_Curve\_Drilling” command from the “Automation” menu or click the corresponding button. In the dialog that opens type “Side-Drill1” as the new ID and confirm with OK.



New Curve Drilling

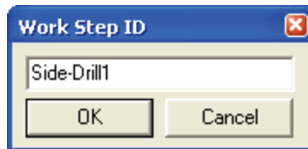

2. Ensure that all parameters on the dialog are set as listed in the table below. When finished, the dialog should be displayed as shown in **Picture 5-26**.

Dialog Field	Value	Comment
Tool Number	3	Tool number on the tool turret / magazine.
Offset #	3	Tool's offset register number.
Diameter	5	Diameter of the drilling tool.
Coolant	FLOOD	
Spindle RPM	1200	Rotation speed of the drilling tool.
Feedrate (Z)	75	Plunging speed of the drilling tool.
Surf (Zs)	40	Radial position of the cutting path's starting point.
Rapid	12	Rapid travel plane (10mm from previous pocket depth + 2mm rapid travel distance).
Clear	2	Distance to switch from rapid move to plunge feedrate.
Depth (Zd)	6	Radial cutting depth.
Step	2.5	Depth of each drilling plunge.
Location	Side	Working plane that has the cutting path on.

MSC ID	SIDE	Machining Coordinate System that is used.
Cycle	Chip Break	Drilling Method that will be used for this step. "Chip Break" drills the whole depth intermittently by the given step value.
Curve ID	CrvSideDrill	Reference curve for toolpath calculation.
Y Axis Output	ON	Spindle will be locked and Y-axis will be used for movements.

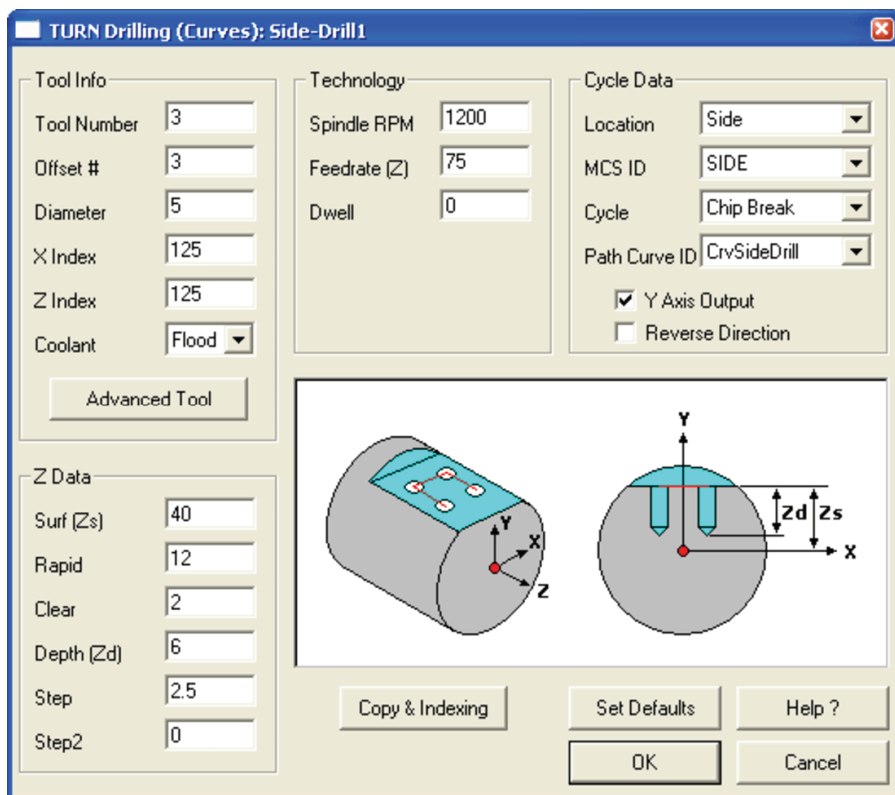

Picture 5-26

3. Click the “Copy & Indexing” button in the “TURN Drilling (Curves)” window to open the “Side Copy & Indexing Options” dialog box and change the “Index Copy” settings according to the table below (see **Picture 5-27**). Confirm the settings by pressing “OK” button. After closing “Copy & Indexing” options, also confirm and close the “TURN Drilling (Curves)” window by pressing its “OK” button.

Dialog Field	Value	Comment
Start Angle	0	Designates the radial starting angle of the toolpath.
Increment Angle	180	Angle between each copied toolpath.
Copies #	2	Total number of toolpath copies that will be duplicated around the part.

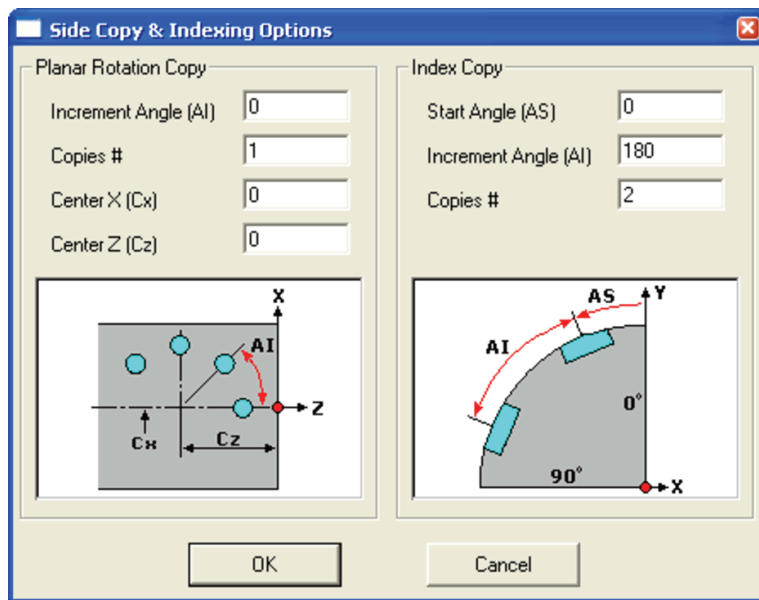

Picture 5-27



- Click the “Verify” button to calculate and display the tool path on the screen as shown in **Picture 5-28**.



Verify

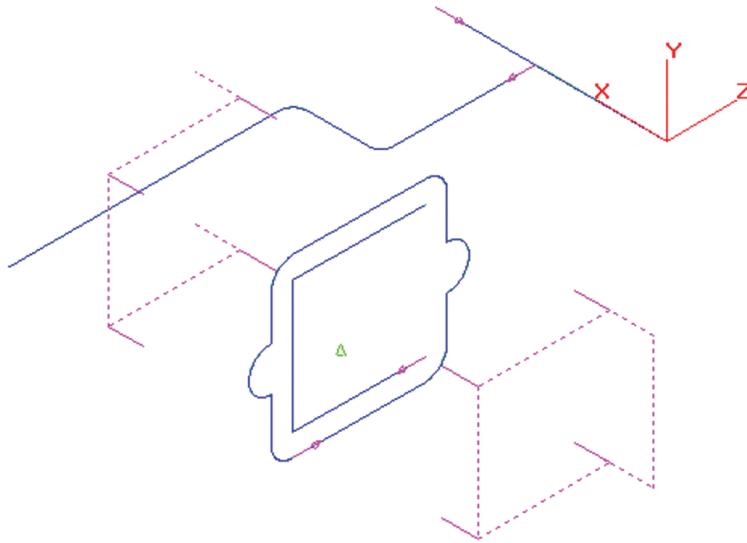

**Picture 5-28**

The Work Step #4 is now complete. Hit the “Redraw” button  to refresh the screen and remove the verified tool path display.



## CREATING WORK STEP #5 (SIDE SLOTTING)

Now we will use the "Custom Shapes Milling" feature that eases machining by eliminating the need to create path curves as it provides a predefined set of shapes. Therefore we only need to define the shape specific dimensions and the location on the currently selected MCS plane to machine the 3 slots that are equally spaced around the smaller diameter section of the part.

1. Select the "New\_Shape\_Milling" command from the "Automation" menu or click the corresponding button. In the dialog that opens type "Side-Slot" as the new ID and confirm with OK.



New Shape Milling

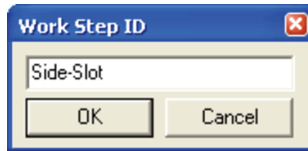

2. Ensure that all parameters on the dialog are set as listed in the table below. When finished, the dialog should be displayed as shown in **Picture 5-29**.

Dialog Field	Value	Comment
Tool Number	4	Tool number on the tool turret / magazine.
Offset #	4	Tool's offset register number.
Diameter	6	Diameter of the milling tool.
Coolant	FLOOD	
Spindle RPM	1200	Rotation speed of the milling tool.
Feedrate (Z)	75	Plunging speed of the milling tool.
Feedrate (XY)	120	Planar moving speed of the tool while cutting.
Surf (Zs)	30	Radial position of the cutting path's starting point.

Rapid	2	This parameter sets the main reference plane of the plunge axis as an absolute value from current MCS ("SIDE") . All other depth and rapid move settings (Rapid, Clear, Depth) are defined in relation to this plane.
Clear	2	This parameter sets the distance at which all rapid XY moves occur above the part. It is an unsigned incremental distance above the "Surf (Zs)"parameter.
Depth (Zd)	3	Radial cutting depth.
Step	1	Incremental depth of each cutting pass.
Location	Side	Working plane that has the cutting path on.
MSC ID	SIDE	<b>M</b> achining <b>C</b> oordinate <b>S</b> ystem that is used.
Y Axis Output	OFF	Y-axis mode is deactivated.
Shape	Slot	Pre-defined shape that will be used for toolpath creation.
Center X (Cx)	0	Arc length between the first slot's position to the part's reference point.
Center Z (Cz)	-17.5	Distance of the slot center to the part's reference position.
Length (L)	10	Length of the tool move that creates the slot.

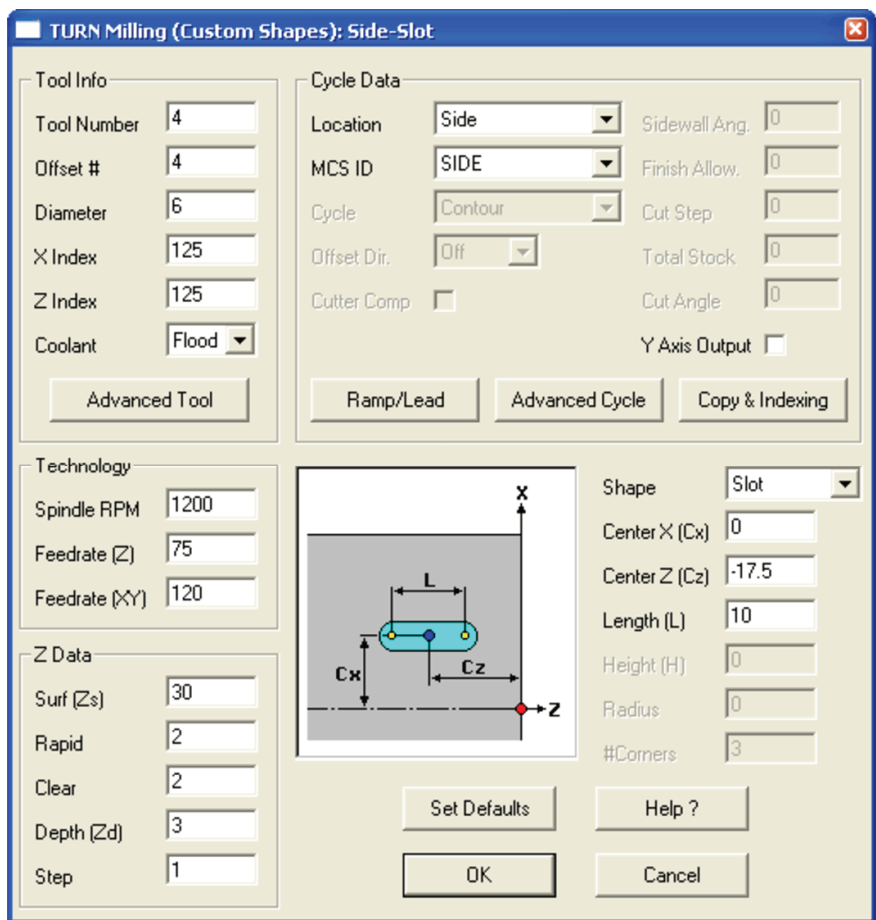

Picture 5-29

3. Click the “Copy & Indexing” button in the “TURN Milling (Custom Shapes)” window to open the “Side Copy & Indexing Options” dialog box and change the “Index Copy” settings according to the table below (see **Picture 5-30**). Confirm the settings by pressing “OK” button. After closing “Copy & Indexing” options, also confirm and close the “TURN Milling (Custom Shapes)” window by pressing its “OK” button.

Dialog Field	Value	Comment
Start Angle	0	Designates the radial starting angle of the toolpath.
Increment Angle	120	Angle between each copied toolpath.
Copies #	3	Total number of toolpath copies that will be duplicated around the part.

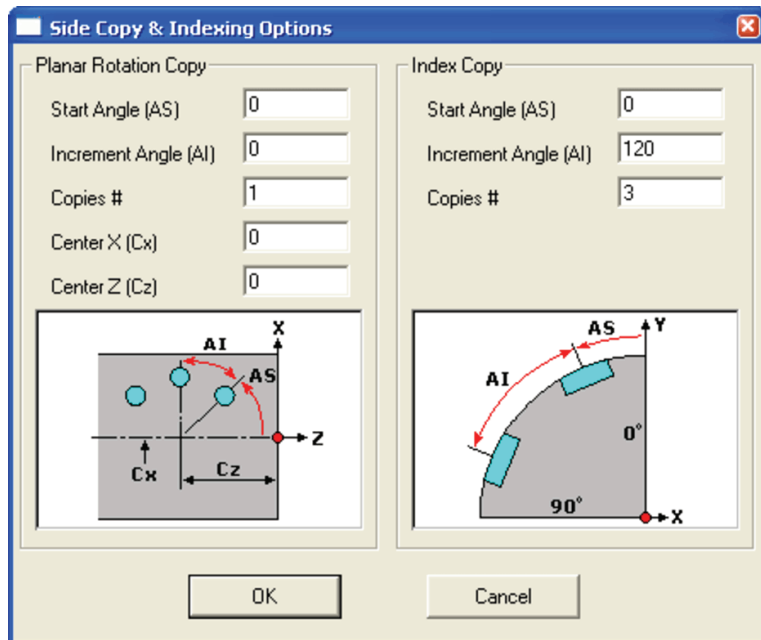

Picture 5-30

- Click the “Verify” button to calculate and display the tool path on the screen as shown in **Picture 5-31**.



Verify

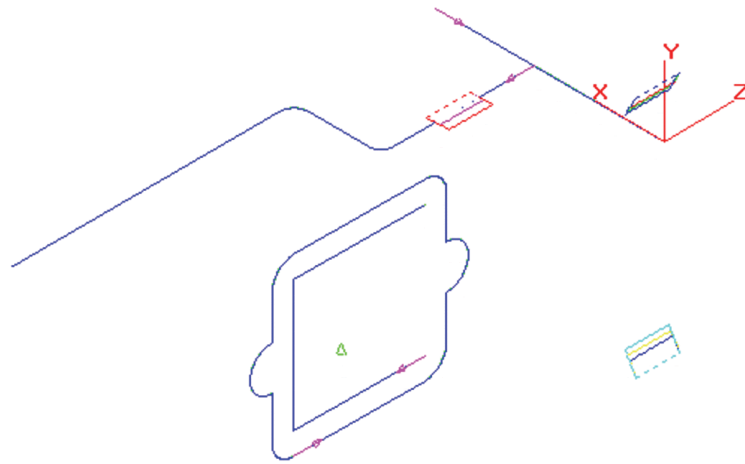

**Picture 5-31**

The Work Step #5 is now complete. Hit the “Redraw” button  to refresh the screen and remove the verified tool path display.

## CREATING WORK STEP #6 (SIDE - PATTERN DRILLING)

This step uses the special "Pattern - Drilling" feature to machine the 3 holes that are located in the center of the previously created slots. The hole locations are defined by selecting a certain pattern with it's associated settings. This again eliminates the need to define any kind of path curve manually.

1. Select the "New\_Pattern\_Drilling" command from the "Automation" menu or click the corresponding button. In the dialog that opens type "Side-Drill2" as the new ID and confirm with OK.



New Pattern Drilling

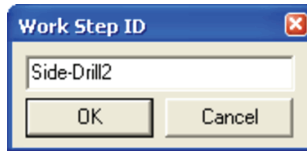

2. Ensure that all parameters on the dialog are set as listed in the table below. When finished, the dialog should be displayed as shown in **Picture 5-32**.

Dialog Field	Value	Comment
Tool Number	5	Tool number on the tool turret / magazine.
Offset #	5	Tool's offset register number.
Diameter	4	Diameter of the drilling tool.
Coolant	FLOOD	
Spindle RPM	1400	Rotation speed of the drilling tool.
Feedrate (Z)	80	Plunging speed of the drilling tool.
Surf (Zs)	27	Radial position of the cutting path's starting point.
Rapid	5	Rapid travel plane (3mm from previous slot depth + 2mm rapid travel distance).
Clear	2	Distance to the starting point, in which rapid vertical tool move is not allowed.
Depth (Zd)	5	Distance to switch from rapid move to plunge feedrate.
Step	1.5	Depth of each drilling plunge.
Location	Side	Working plane that has the cutting path on.

MSC ID	SIDE	<b>Machining Coordinate System</b> that is used.
Cycle	Chip Break	Drilling Method that will be used for this step. "Chip Break" drills the whole depth intermittently by the given step value.
Y Axis Output	OFF	Y-axis mode is deactivated.
Retract to Z Rapid	ON	Performs a movement that retracts the tool to the rapid plane.
Pattern	Rectangle	Pattern that defines the hole positions.
Start X (Sx)	0	Arc length between the first hole's position to the part's reference point.
Start Z (Sz)	-17.5	Distance between the hole center and the part's reference position on Z-axis.
X Spacing (Dx)	0	Arc length between each row of holes.
Z Spacing (Dz)	0	Distance between each column on Z-axis.
# Rows	1	Number of hole rows around the part.
# Columns	1	Number of hole columns on Z-axis.



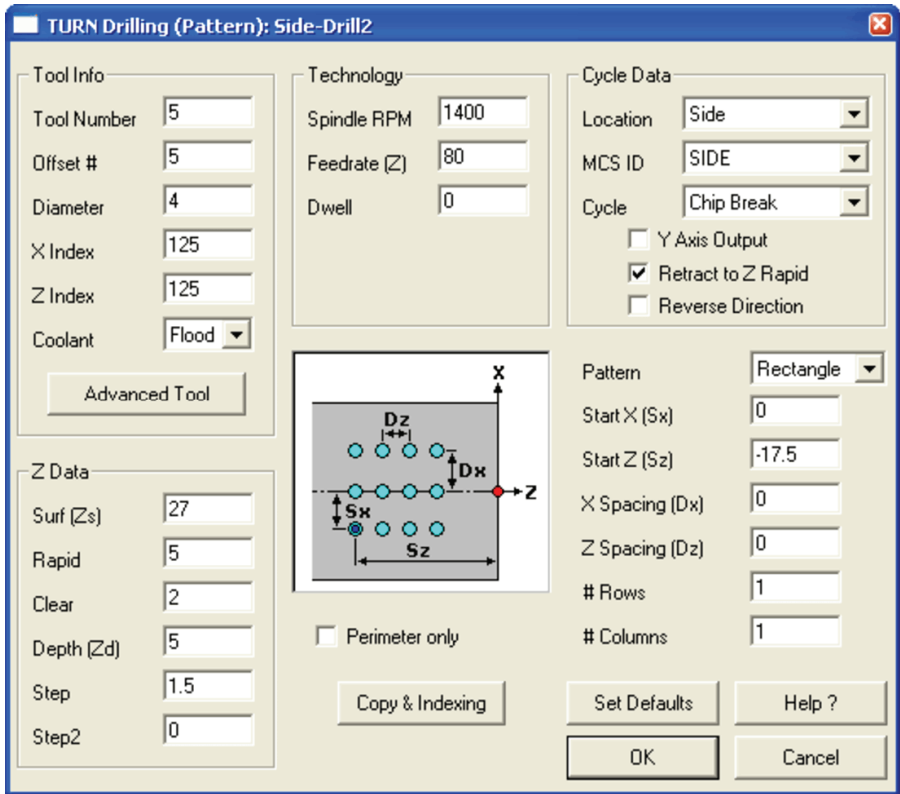

Picture 5-32

3. Click the “Copy & Indexing” button in the “TURN Drilling (Pattern)” window to open the “Side Copy & Indexing Options” dialog box and change the “Index Copy” settings according to the table below (see **Picture 5-33**). Confirm the settings by pressing “OK” button. After closing “Copy & Indexing” options, also confirm and close the “TURN Drilling (Pattern)” window by pressing its “OK” button.

Dialog Field	Value	Comment
Start Angle	0	Designates the radial starting angle of the toolpath.
Increment Angle	120	Angle between each copied toolpath.
Copies #	3	Total number of toolpath copies that will be duplicated around the part.

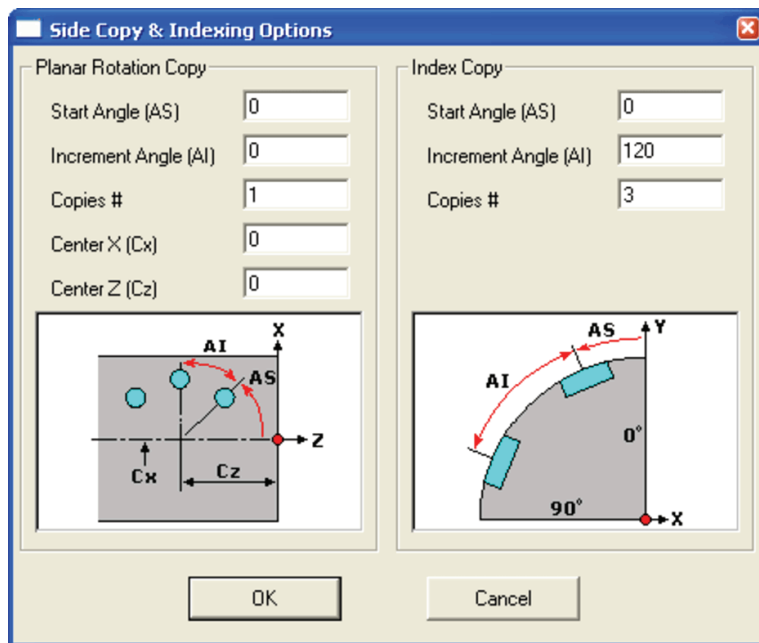

Picture 5-33

- Click the “Verify” button to calculate and display the tool path on the screen as shown in **Picture 5-34**.



Verify

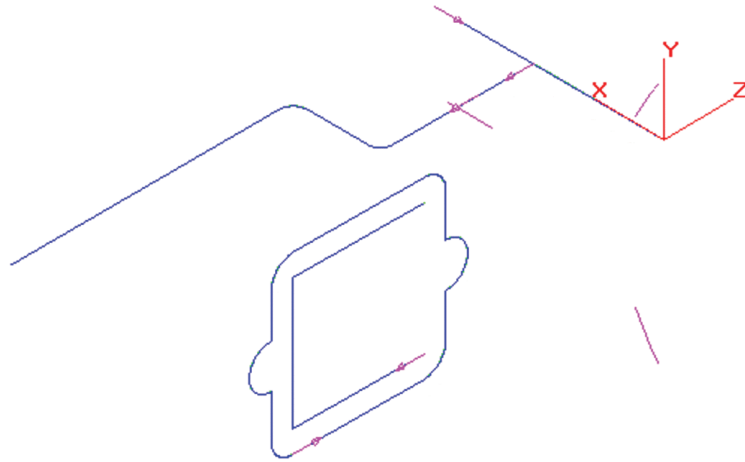

**Picture 5-34**

The Work Step #6 is now complete. Hit the “Redraw” button  to refresh the screen and remove the verified tool path display.



## CREATING WORK STEP #7 (FACE - PATTERN DRILLING)

As in the previous work step we will again use the "Pattern Drilling" feature to machine the 6 holes of the bolt-hole circle on the face.

1. Select the "New\_Pattern\_Drilling" command from the "Automation" menu or click the corresponding button. In the dialog that opens type "Face-Drill" as the new ID and confirm with OK.



New Pattern Drilling

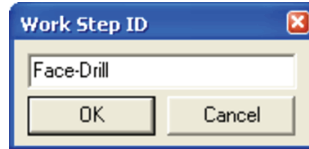

2. Ensure that all parameters on the dialog are set as listed in the table below. When finished, the dialog should be displayed as shown in **Picture 5-35**.

Dialog Field	Value	Comment
Tool Number	6	Tool number on the tool turret / magazine.
Offset #	6	Tool's offset register number.
Diameter	8	Diameter of the drilling tool.
Coolant	FLOOD	
Spindle RPM	1500	Rotation speed of the drilling tool.
Feedrate (Z)	75	Plunging speed of the drilling tool.
Surf (Zs)	-35	Z-axis position of the face to be drilled.
Rapid	37	Distance to the drilling face, in which rapid moves on the same plane are not allowed.
Clear	2	Distance to the starting point, in which vertical rapid tool move is not allowed.
Depth (Zd)	5	This parameter sets how far below the "Surf (Zs) parameter the tool will cut.
Location	Face-Left	Working plane that has the cutting path on.
MSC ID	FACE	<b>M</b> achining <b>C</b> oordinate <b>S</b> ystem that is used.
Cycle	Drill	Cutting method that will be used for this step.
Pattern	Circle	Pattern that defines the hole positions.

Center X (Cx)	0	X-axis location of the pattern circle center.
Z Center (Cz)	0	Z-axis location of the pattern circle center.
# Holes	6	Number of holes that will be placed around the pattern circle with equal spacing.
Radius	40	Radius of the pattern circle.
Start Angle	0	Angle of the first hole location according to the part's reference.

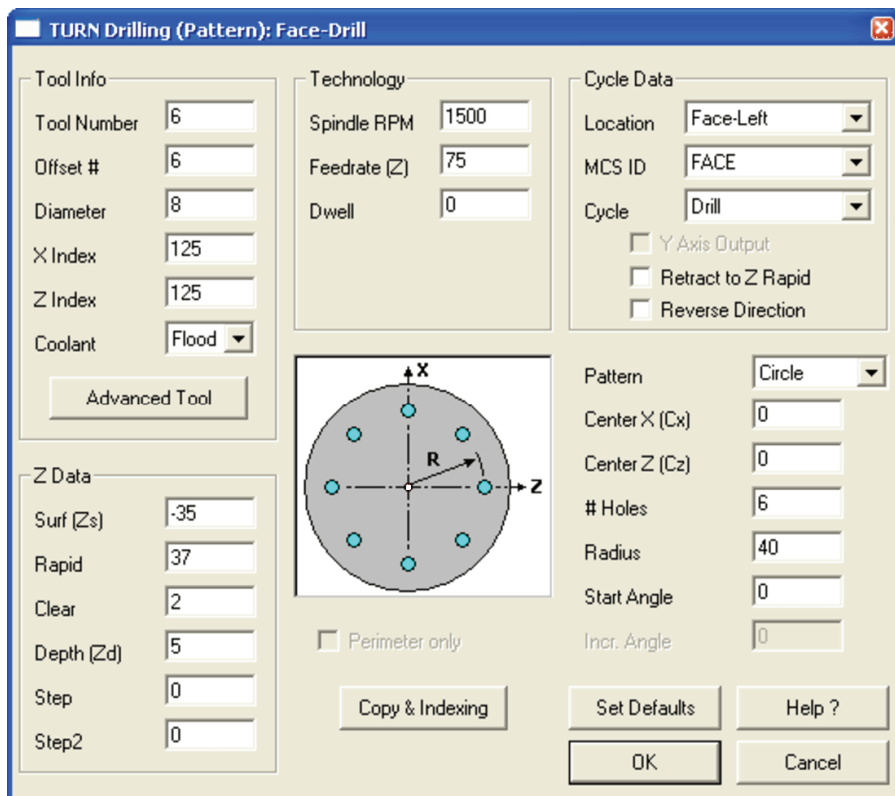

Picture 5-35

- Click the “Verify” button to calculate and display the tool path on the screen as shown in **Picture 5-36**.



Verify

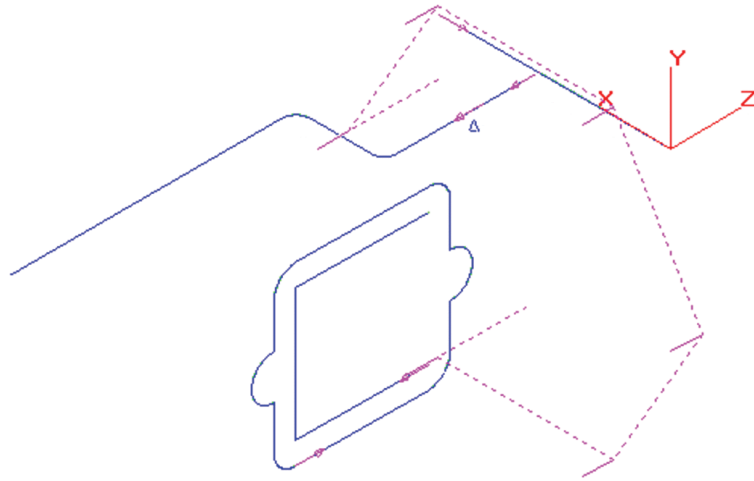

**Picture 5-36**

The Work Step #7 is now complete. Hit the “Redraw” button  to refresh the screen and remove the verified tool path display.



## CREATING WORK STEP #8 (FACE SLOTTING)

The last work step will machine the slot on the face of the part by using the "Shape Milling" feature.

1. Select the "New\_Shape\_Milling" command from the "Automation" menu or click the corresponding button. In the dialog that opens type "Face-Slot" as the new ID and confirm with OK.



New Shape Milling

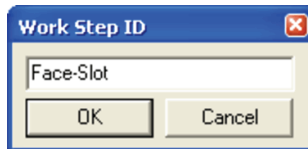

2. Ensure that all parameters on the dialog are set as listed in the table below. When finished, the dialog should be displayed as shown in **Picture 5-37**.

Dialog Field	Value	Comment
Tool Number	7	Tool number on the tool turret / magazine.
Offset #	7	Tool's offset register number.
Diameter	10	Diameter of the milling tool.
Coolant	FLOOD	
Spindle RPM	1200	Rotation speed of the milling tool.
Feedrate (Z)	75	Plunging speed of the milling tool.
Feedrate (XY)	120	Planar moving speed of the tool while cutting.
Surf (Zs)	0	Z-axis position of the face - Machining starting point.
Rapid	2	Distance to the machining face, in which rapid moves on the same plane are not allowed.
Clear	2	Distance to the starting point, in which rapid vertical tool move is not allowed.
Depth (Zd)	5	Cutting depth.
Step	1.5	Depth of each cutting pass.

Location	Face-Left	Working plane that has the cutting path on.
MSC ID	FACE	<b>M</b> achining <b>C</b> oordinate <b>S</b> ystem that is used.
Cycle	Pocket (Standard)	Cutting Method that will be used for this step.
Cut Step	2	Distance between each pocket loop.
Y Axis Output	OFF	Y-axis mode is deactivated.
Shape	Rectangle	Pre-defined shape that will be used for toolpath creation.
Center X (Cx)	0	X-axis position of the rectangle center.
Center Z (Cz)	0	Z-axis position of the rectangle center.
Length (L)	68	Length of the rectangle on Z-axis.
Height (H)	15	Height of the rectangle on X-axis.
Radius	0	Corner radius of the rectangle.



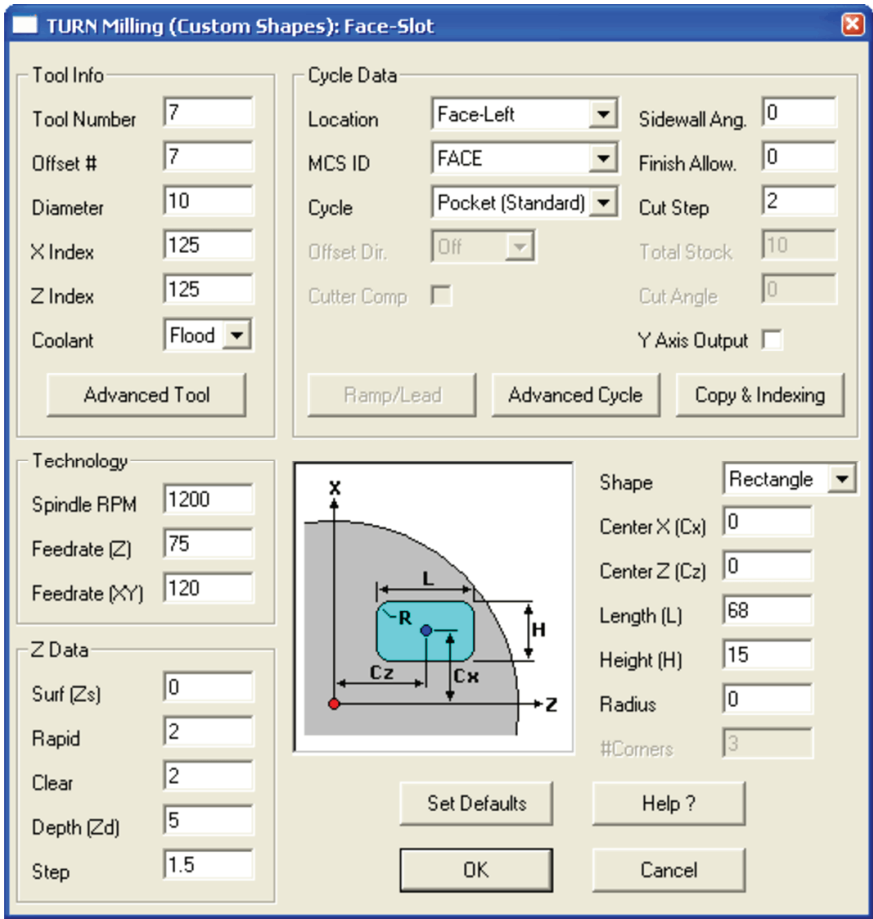

Picture 5-37

3. Click the “Verify” button to calculate and display the tool path on the screen as shown in **Picture 5-38**.



Verify

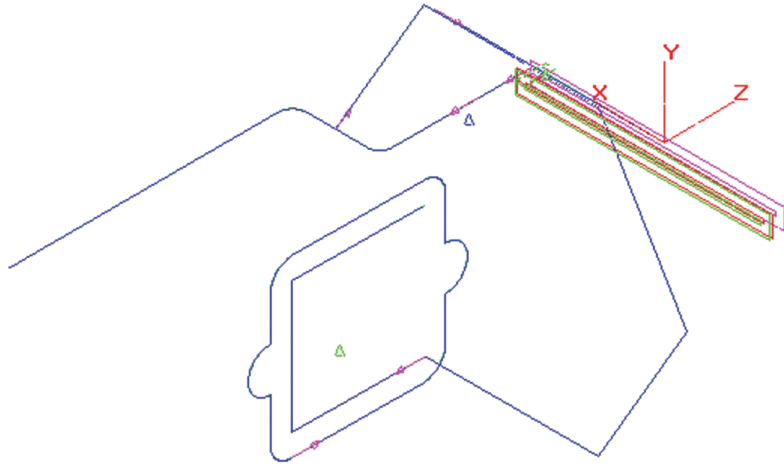

**Picture 5-38**

The Work Step #8 is now complete. Hit the “Redraw” button  to refresh the screen and remove the verified tool path display.

## VERIFYING ALL TOOL PATHS

In this tutorial, you have verified the tool path of each Work Step individually. The “Verify All” command in the “Post” menu is used to estimate the total time it will take to machine the part. It automatically performs an on-screen verification of all of the part program Work Steps in memory, in the machining order. The total machining time (excluding rapid traverse or tool change time) is displayed in a dialog box at the end of the verification process.



Verify All

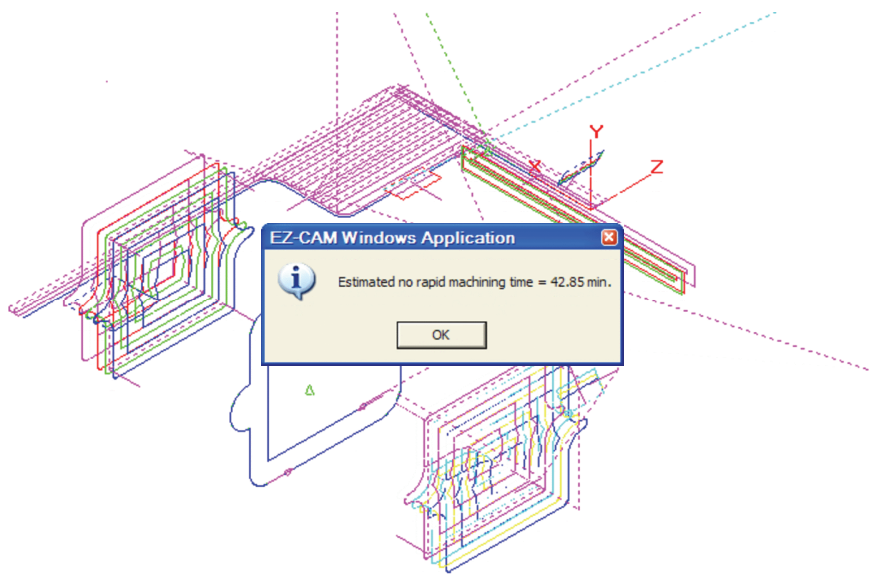

Picture 5-39

### 3D SOLID PREVIEW

One of the most powerful EZ-CAM features is the “3D Solid Preview” function. This function shows an animated tool cutting a solid model of the programmed part. The stock size is automatically calculated according to the calculated tool movements. Once the simulation is finished or interrupted by the user pressing “Esc” key, all dynamic view commands to rotate, zoom or move the simulated model on the screen are available.

1. Select the “Preview 3D” command from the “Machining” menu or the corresponding button. See **Picture 5-40**.



Preview 3D

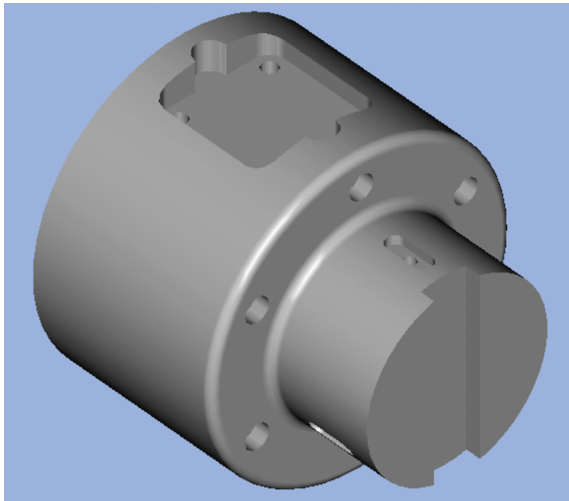

**Picture 5-40**

2. Once the simulation stopped you can change the on-screen view by using the dynamic view commands (Rotate, Pan, Zoom) under the “View / Dynamic Viewing” menu.



Dynamic Rotate



Dynamic Zoom



Dynamic Pan

## SAVING THE PART

It is very important to save the newly created or edited part from memory to disk periodically during a session as well as at the end to ensure that no information is lost. The EZ-CAM “Save” and “Save As” commands under the “File” menu transfer files from system memory to a hard disk or other media. In EZ-TURN, the part information is stored in two different types of files, the “Part” file using the extension "TRN" and the associated “Geometry” file with extension "GEO". This flexibility allows the user to load an existing part file to be used with newly created geometry and path curves.

File Type : **GEOMETRY**  
 Extension : **GEO**  
 Data : Geometry Elements (lines, arcs, etc.), Curves,  
 User-Coordinate Systems (UCS)

File Type : **PART Files**  
 Extension : **TRN**  
 Data : Work Step Data (Technology & Machining Information)

There is no specific rule what should be saved first. Of course, if there is only one kind of data in memory (Work Steps or Geometry) the “Save As” dialog will automatically open with the correct file type.

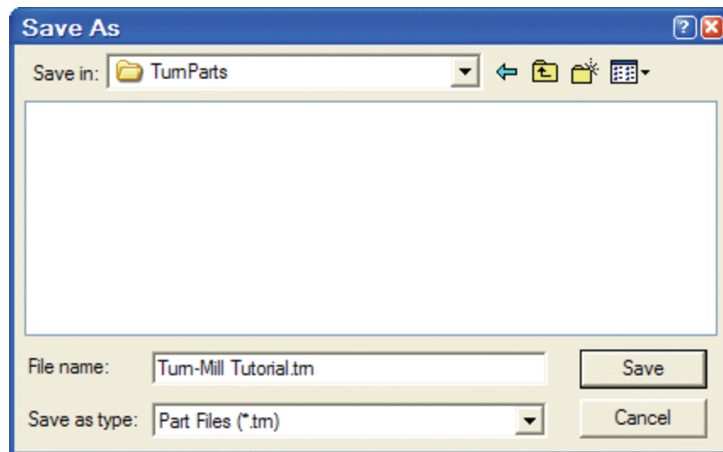

Picture 5-41

1. Select “Save As” command from the “File” menu.
2. Select the appropriate drive and folder where the geometry and part files should be stored. You can use the “EZCAMW \ TURNPARTS” folder that was automatically created by the setup routine.
3. Select “Geometry (\*.GEO)” from the “Save as type” list box to store the geometry data.
4. Type the new filename “Turn-Mill Tutorial” in the File Name box and click the “Save” button. The file extension is added automatically.
5. To store the machining information (Work Step Data) select “Part Files (\*.TRN)” from the “Save as type” list box and click “Save” again.



If you have already saved the geometry, the software automatically inserts a part file with the same name but different extension (\*.TRN) in the “Save” menu when the first Work Step is created. All you have to do is to select “Save All” option from the “File” menu or the corresponding toolbar button.

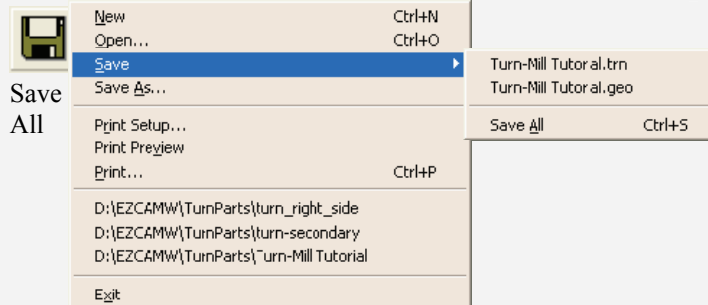

The software will save and overwrite the existing files without any screen prompt. You can use this command anytime for fast saving of your work.



It is not possible to save data when the software is running in evaluation mode. The “Save”, “Save as” and “Print” commands are disabled.

## CREATING CNC CODE

Now that the part program has been created, it must be converted to run on a NC control by running the “Post” command with the appropriate “Post-Processor” for your machine.



The CNC data file or “Post-Processor” is used as a "template" to format the part program data file that was created in EZ-Turn. This template consists of program formats (e.g., TOOL CHANGE, LINEAR MOVE, etc.) that determine the structure of a part program for a specific CNC. To create or edit a “Post-Processor” a special editor called “TBuild” is required.

1. Select “Post” command in the “Machining” menu to open the “Post Process” dialog.

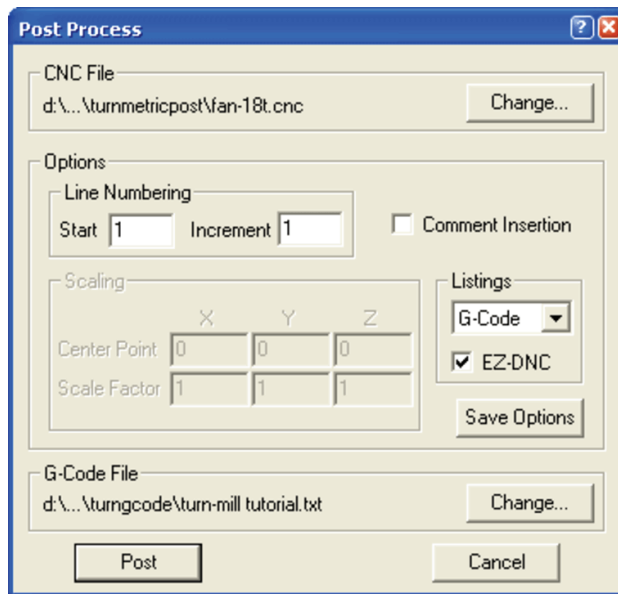

Picture 5-42

2. First you need to select the postprocessor. If the one desired is already loaded and displayed in the section “CNC-File”, continue to the next step. Otherwise use the “Change” button to browse your system for a different one. For this tutorial you may use the “FAN-18T.CNC” post (standard metric post that creates Fanuc style code).



Standard postprocessor folders created by the EZ-CAM v15 setup:

INCH

<DRIVE>: \ EZCAMW \ EZCAM15 \TURNINCHPOST

METRIC

<DRIVE>: \ EZCAMW \ EZCAM15 \TURNMETRICPOST

3. Select the “G-Code” option from the “Listings” list box. The computed program text will be displayed on the screen.
4. Activate (check) the “EZ-DNC” option. This will automatically start the “EZ-DNC” application when posting of the part file is finished and load the newly created file for sending it top the machine using the serial port.
5. Next is the “G-Code File” section. Here the default name and directory for the computed program file is displayed. The name is taken from the part file that was saved before. The default directory is “EZCAMW\TURNGCODE”.



Ensure that part file and postprocessor share the same dimension unit (“Metric” for this tutorial). The system will generate a “Dimension Unit Conflict” message, but then automatically scale the NC-Code according to the dimension specified in the postprocessor.

See online help for more information about the “Setup” dialog located in the “View” menu.



- Click the “Post” to start posting. The Processing window will be displayed showing messages followed by listings of ASCII code created. When all Work Steps have been processed, a final message box is displayed as shown in **Picture 5-40**.

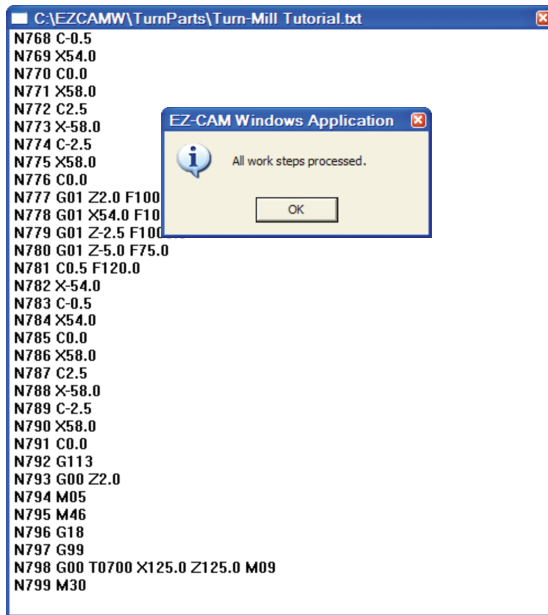

**Picture 5-43**

- Click OK to close the message dialog box. To close the Processing window click  at the top right-hand corner of the window.

**Congratulations!**

**You've completed the EZ-Turn & Live-Tool Operations Tutorial !**



## CHAPTER 6.

# COMMUNICATION WITH THE CONTROL

### COMMUNICATION WITH THE CONTROL

When the part program is posted with the “EZ-DNC” option checked, “EZ-DNC” application starts and automatically loads the newly created file as shown in **Picture 6-1**. “EZ-DNC” is a light version of the EZCAM “Filtermax” application and limited to editing and serial (RS232) communication functionality. Next step would be to load the correct communication settings (Port, Baudrate, Handshake, etc.) for the control and starting the file transfer. See EZ-DNC online help for more information.

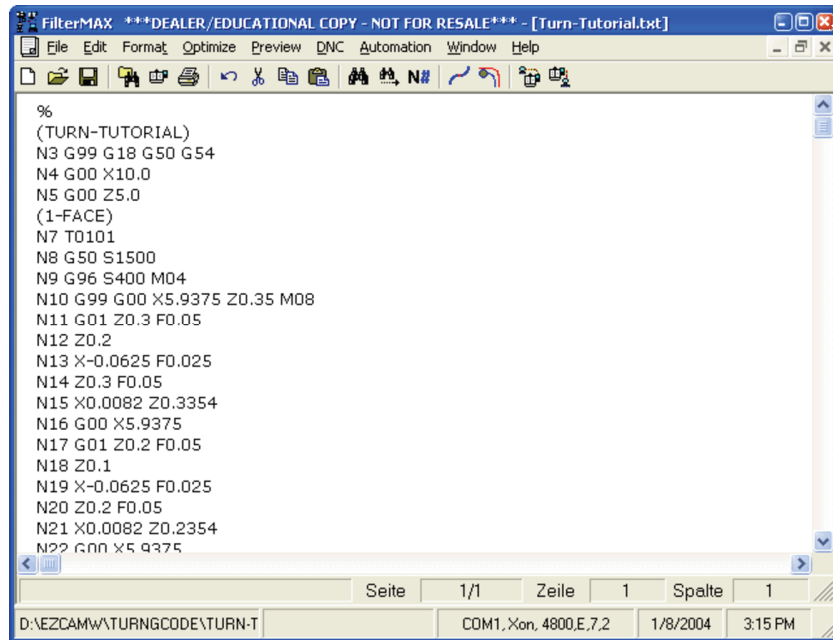

Picture 6-1

1. Open the “RS232 Settings” dialog through the “DNC” menu to check the serial port related communication settings. Close the dialog using OK button.

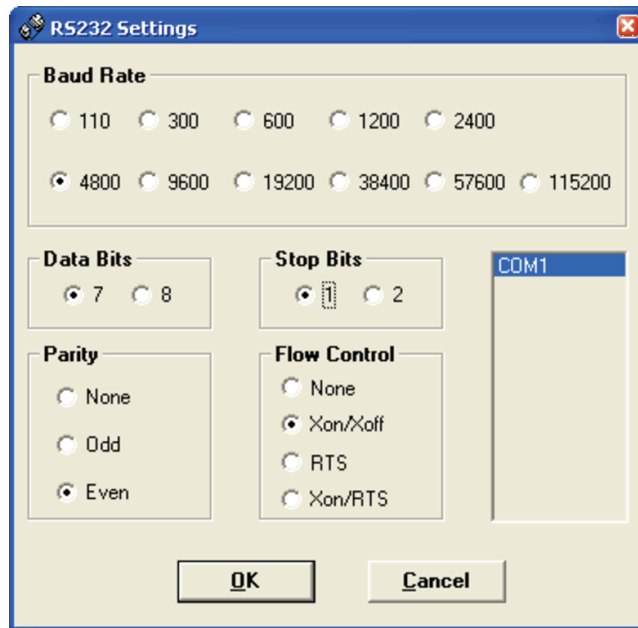

**Picture 6-2**



The system automatically saves all current settings as defaults for future sessions.

You can also use the “Save Settings” and “Load Settings” commands from the “File” menu to work with settings for different types of controls.

The EZ-CAM setup has already copied setting files (\*.PAR) for most common controls into the “EZCAMW\FilterMAX\ParFiles” folder.

“FilterMAX..” stands for the directory of the currently installed software release (FilterMAX6 , FilterMAX7, etc.)

2. Open the “DNC Settings” dialog through the “DNC” menu to check special character settings and filters. See **Picture 6-3**.

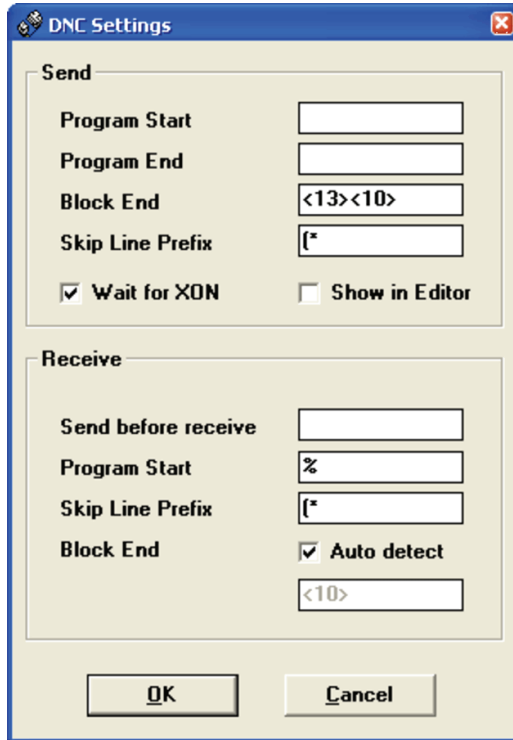

**Picture 6-3**

3. Start to send the NC file in the editor by selecting the “Send Text” command from the “DNC” menu.



Depending on the type of control you may start the controls “Receive” function before selecting the “Send text” command.

### CABLE DIAGRAMS

In order for the EZ-CAM computer to send a part program to the control it must be connected to the machine with a cable. The wiring layout strongly depends on the communication software, the type of control and selected handshake mode (XON/XOFF or RTS/CTS). There may be additional considerations such as the usage of existing wiring that might limit communication functionality. The graphics shown below represent connection diagrams that will work with some of the most common controls (Fanuc, Heidenhain, etc.). The last diagram (“Universal”) also handles the DSR, DCD and DTR signals required by some controls.

#### CABLE LAYOUT 1: XON /XOFF SOFTWARE HANDSHAKE (FANUC)

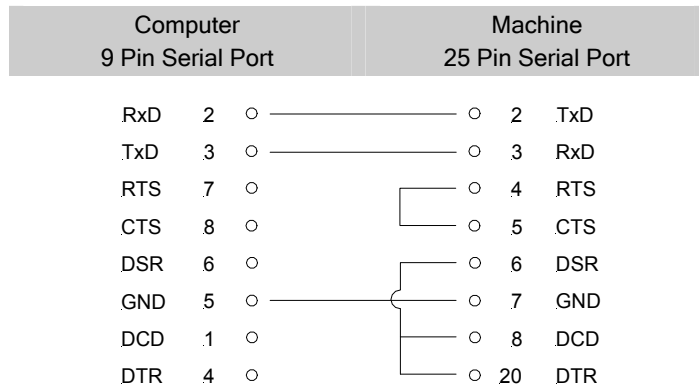
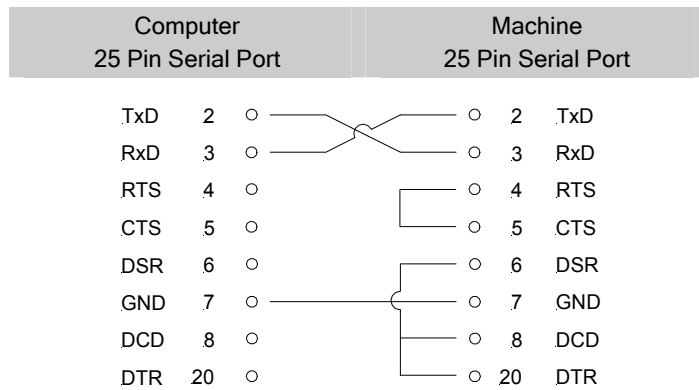

CABLE LAYOUT 2:  
RTS /CTS HARDWARE HANDSHAKE (HEIDENHAIN)

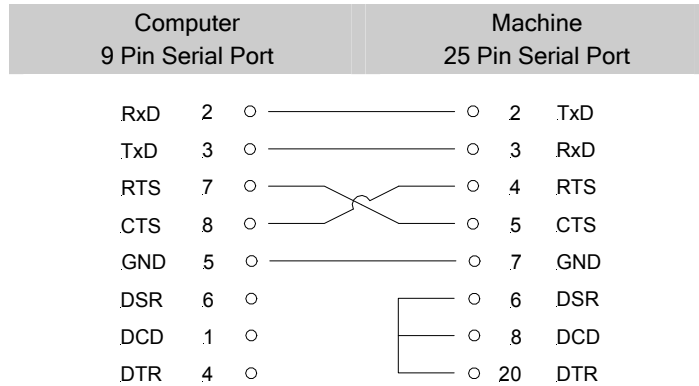
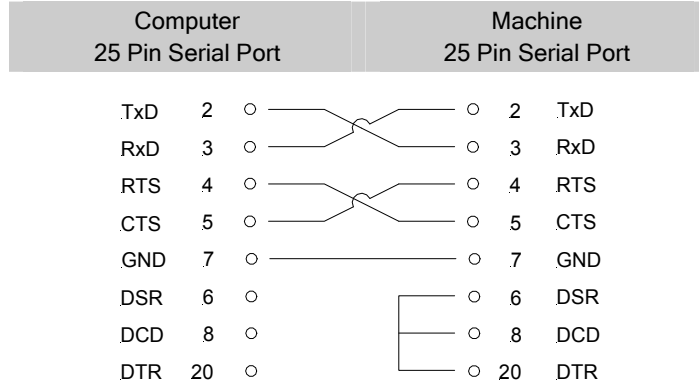

CABLE LAYOUT 3:  
UNIVERSAL (XON/XOFF AND/OR RTS/CTS)

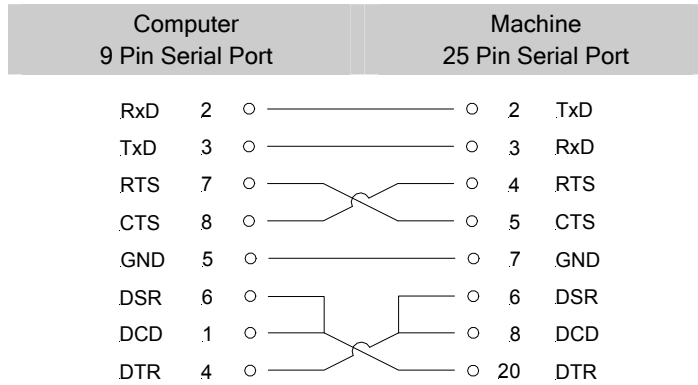
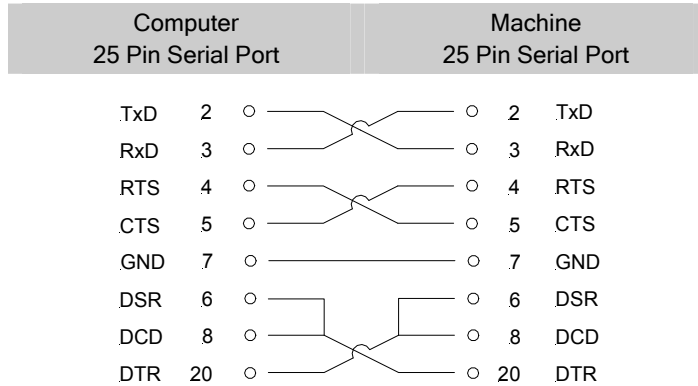

In case of trouble you may also consult the control's documentation or contact the machine tool dealer for more information about parameter settings and file transfer procedures.

You may also consult the "EZ-DNC" online help for more information.